

**sealing**systems



*ASTON SEALS*

general**catalogue**



**wipers**  
rod seals  
**piston seals**  
guide rings  
**back-up rings**  
o-rings  
**lathe-cut products**





## Technical information

<b>The hydraulic cylinder</b>	<b>8</b>	Trademark names of the common materials	22
<b>Application examples by operating features</b>	<b>9</b>	Shelf life	23
		Most popular fluids compatibility table	24
<b>Mechanics of sealing</b>	<b>10</b>	Other fluids compatibility table	25
Pressure	10		
Speed	11	<b>Housing construction</b>	<b>57</b>
Temperature	11	Gap widths	57
Friction	12	Surface texture	58
Wear and seal life	13	Lead-in chamfer	58
<b>Materials</b>	<b>14</b>	<b>Installation</b>	<b>59</b>
Hardness	14	General assembly suggestions	59
Elastic recovery	14	Installation guidelines for rod seals	59
Elastic modulus	15	Installation guidelines for piston seals	59
Tensile strength	15		
Abrasion resistance	15	<b>Trouble shooting</b>	<b>60</b>
Tear resistance	16		
Operating temperature	16	<b>General technical data</b>	<b>61</b>
Materials	17	Conversion table	61
General properties of the common elastomers	21	Tolerance chart - ISO	62

8

Wipers

64

Rod seals

96

Piston seals

148

Rod and piston seals

198

Guide rings

224

Other

252

Lathe-cut products

304

# Product index

## WIPERS

Type		Pressure (bar)				Temperature (°C)				Speed (m/s)				Material	Pag.
SA		-				-40 ÷ +100				0.8				TPU	64
SAF		-				-40 ÷ +100				0.8				TPU	68
SAP		-				-40 ÷ +110				4.0				TPE	72
SAG		-				-40 ÷ +100				0.8				TPU	74
SAC		-				-40 ÷ +100				0.8				TPU	76
SAW		-				-40 ÷ +100				0.8				TPE	78
SAB		15				-40 ÷ +100				0.8				TPU	80
SAD		-				-40 ÷ +100				0.8				TPU	82
SAF/GM		-				-40 ÷ +100				0.8				TPU + Metal	84
SMI		-				-30 ÷ +100				2.0				NBR + Metal	86
SMA		-				-30 ÷ +100				2.0				NBR + Metal	88
SAA		-				-40 ÷ +100				0.8				TPU	90
S1A		-				-30 ÷ +130 (-30 ÷ +200)				15				PTFE + NBR (PTFE + FKM)	92
S2A		-				-30 ÷ +130 (-30 ÷ +200)				15				PTFE + NBR (PTFE + FKM)	94

# Product index

## ROD SEALS

Type		Pressure (bar)	Temperature (°C)	Speed (m/s)	Material	Pag.
SD		400	-40 ÷ +100	0.5	TPU	96
SDA		700	-40 ÷ +100	0.5	TPU + POM	102
SDAN		700	-40 ÷ +100	0.5	TPU + NBR + POM	104
S		400	-40 ÷ +100	0.5	TPU	106
A		400	-40 ÷ +100	0.5	TPU	108
AD		400	-40 ÷ +100	0.5	TPU	112
ADA		700	-40 ÷ +100	0.5	TPU + POM	116
AR		250	-40 ÷ +100	0.5	TPU	118
ARA		700	-40 ÷ +100	0.5	TPU + POM	120
SHT		500	-30 ÷ +100	0.5 (<100°C) 1.0 (<80°C)	TPE + NBR	122
SGA		700	-40 ÷ +110	0.5	NBR + POM + TPE	124
AV		300	-200 ÷ +200	15	PTFE + INOX	126
XB		600	-30 ÷ +130 (-30 ÷ +200)	15	PTFE + NBR (PTFE + FKM)	130
XAB		600	-30 ÷ +130 (-30 ÷ +200)	15	PTFE + NBR (PTFE + FKM)	134

# Product index

## ROD SEALS

Type		Pressure (bar)	Temperature (°C)	Speed (m/s)	Material	Pag.
<b>XRБ</b>		400	-30 ÷ +130 (-30 ÷ +200)	1	PTFE + NBR (PTFE + FKM)	138
<b>XL</b>		160	-30 ÷ +130 (-30 ÷ +200)	2	PTFE + NBR (PTFE + FKM)	142
<b>XC</b>		210	-30 ÷ +130 (-30 ÷ +200)	4	PTFE + NBR (PTFE + FKM)	144

## PISTON SEALS

Type		Pressure (bar)	Temperature (°C)	Speed (m/s)	Material	Pag.
<b>KD</b>		400	-40 ÷ +100	0.5	TPU	148
<b>KDA</b>		500	-40 ÷ +110	0.5	TPU + POM	152
<b>KDF</b>		400	-40 ÷ +100	0.5	TPU + POM	154
<b>SP</b>		-	-40 ÷ +110	-	POM	156
<b>KPD</b>		400	-30 ÷ +100	0.5	TPU + NBR	158
<b>KPR</b>		400	-30 ÷ +100	0.5	TPU + NBR	160
<b>KGD</b>		400	-40 ÷ +110	0.5	NBR + POM + TPE	162
<b>KGD/AE</b>		400	-40 ÷ +110	0.5	NBR + POM + TPE	168
<b>KHT</b>		500	-30 ÷ +100	0.5 (<100°C) 1.0 (<80°C)	TPE + NBR	172

# Product index

## PISTON SEALS

Type		Pressure (bar)	Temperature (°C)	Speed (m/s)	Material	Pag.
KV		300	-200 ÷ +200	15	PTFE + INOX	174
YB		600	-30 ÷ +130 (-30 ÷ +200)	15	PTFE + NBR (PTFE + FKM)	178
YAB		600	-30 ÷ +130 (-30 ÷ +200)	15	PTFE + NBR (PTFE + FKM)	182
KHD		500	-40 ÷ +120	1.5	PTFE + NBR + POM	186
YL		160	-30 ÷ +130 (-30 ÷ +200)	2	PTFE + NBR (PTFE + FKM)	188
YP		210	-30 ÷ +130 (-30 ÷ +200)	4	PTFE + NBR (PTFE + FKM)	190
YRB		400	-30 ÷ +130 (-30 ÷ +200)	1	PTFE + NBR (PTFE + FKM)	194

## ROD AND PISTON SEALS

Type		Pressure (bar)	Temperature (°C)	Speed (m/s)	Material	Pag.
UP		400	-40 ÷ +100	0.5	TPU	198
UPN		400	-40 ÷ +100	0.5	TPU + NBR	204
OP		500	-30 ÷ +80	*	TPU	210
HP		400	-30 ÷ +130	0.5	NBR + Fabric	214

# Product index

## GUIDE RINGS

Type		Pressure (bar)				Temperature (°C)				Speed (m/s)				Material	Pag.
<b>FI</b>		-				-40 ÷ +110				1				POM	224
<b>FIL</b>		-				-40 ÷ +110				1				POM	228
<b>FIT</b>		-				-40 ÷ +110				1				POM	230
<b>FE</b>		-				-40 ÷ +110				1				POM	232
<b>FR</b>		-				-40 ÷ +110				1				POM	236
<b>GRF</b>		-				-40 ÷ +130				1				Phenolic	240
<b>GRB</b>		-				-50 ÷ +200				5				PTFE	244
<b>MRB</b>		-				-50 ÷ +200				5				PTFE	248
<b>FSP</b>		-				-40 ÷ +110				0.8				POM	250

# Product index

## OTHER

Type		Pressure (bar)	Temperature (°C)	Speed (m/s)	Material	Pag.
OR		*	-30 ÷ +110	*	NBR	252
AP		*	-40 ÷ +140	0.8	TPE	284
AM		*	-40 ÷ +140	0.8	TPE	290
BRC		500	-200 ÷ +200	2	PTFE	294
BRT		400	-200 ÷ +200	2	PTFE	296
BRA		400	-200 ÷ +200	2	PTFE	298
PFS		500	-40 ÷ +100	-	TPU	300
DV		-	-40 ÷ +100	-	TPU	302

\* depending on working conditions





# The hydraulic cylinder

**PISTON SEAL**









KGD













**O-RING**

	OR		OR+AP (+AM)
	OR + BRC		OR + BRT
	OR + BRA		

**ROD GUIDE RING**



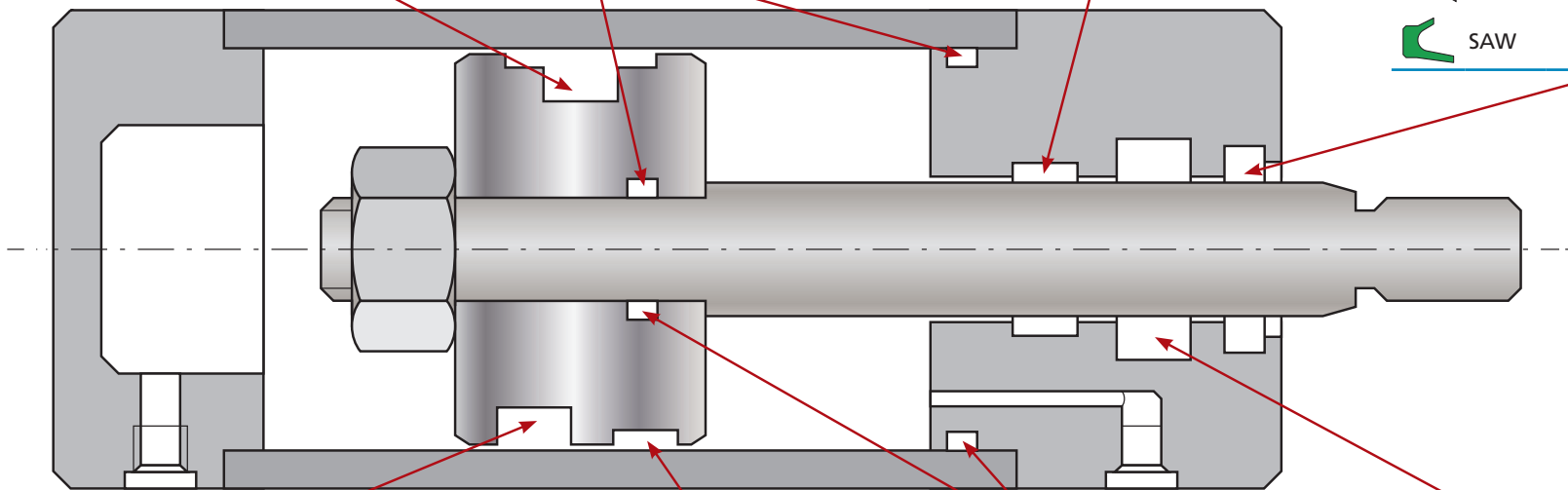

	FI		FIL
	FIT		FR
	GRF		GRB

**ROD WIPER**















	SA		SAF/GM		SAF
	S1A		SAP		S2A
	SAB		SMI		SAC
	SMA		SAG		SAD
	SAW				







**OTHER**

	SAA
	DV
	XRB
	YRB
	PFS

**PISTON SEAL**

	YAB		KDA		YL		KDF
	YP		KPD		KHD		KPR
	KV		UP		HP		UPN
	KHT		KGD/AE				



















**PISTON GUIDE RING**

	FE		GRB
	FR		FSP
	GRF		

**STATIC SEAL**

	OP
---	----

**ROD SEAL**

	SD		SDA		S		SDAN
	AD		UP		A		UPN
	XB		ADA		AR		ARA
	SHT		XAB		XC		SGA
	XL		HP		AV		



# Application examples by operating features

The following diagrams show some examples of how Aston Seals' products can be used in various types of cylinders

## HEAVY DUTY

Piston sealing system			Rod sealing system		
HP	GRF	HP	GRF	HP	SAP
GRF	KHD	GRF	GRF	SGA	SAP
KDA	GRF	KDA	GRF	SDAN	SA

## MEDIUM DUTY

Piston sealing system			Rod sealing system			
KDA	GRF	KDA	GRF	ARA	AD	SA
			FI/FR	SHT	AD	SAG
FE/FR	KPD	FE/FR	FI/FR	ADA	SAB	
KD	FE/FR	KD	FI/FR	SDA	SA	

## LIGHT DUTY

Piston sealing system			Rod sealing system		
KD	FE/FR	KD	FI/FR	SD	SA
FE/FR	KPD	FE/FR	FI/FR	A	SAB
			FI/FR	SD	SA

## HIGH SPEED

Piston sealing system			Rod sealing system			
GRB	YB	GRB	GRB	XB	XB	S2A

For non-standard applications please contact our technical department

# Mechanics of sealing

The demand of seals for hydraulic cylinders is to prevent the flow of fluid across two surfaces in relative movement and to maintain a high level of sealing performance during their service life under the operating conditions for which they have been chosen.

During the movement a drag flow develops through the sliding motion and, as consequence of a hydrodynamic growth of pressure, the seal is lifted off the sliding surface and a thin film of fluid remains between the seal and the sliding surface. The thickness of this film of fluid is regulated by the following formula:

$$s = K \cdot \sqrt{\frac{\eta VL}{P}}$$

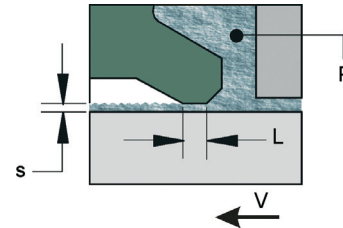

where

- s • thickness of the film of fluid
- K • coefficient (≈ 2,3)
- η • fluid viscosity
- V • speed
- L • length of the surfaces in relative movement
- P • pressure

Since the thickness of this film is the amount of fluid that goes through the seal during the movement, it can be considered within certain limits as something equivalent to a leakage.

## Pressure

The pressures acting on the seals are those caused by the hydraulic pump of the circuit ( $P_p$ ) and that created by the movement of the cylinder, called "drag pressure" ( $P_t$ ):

$$P_{tot} = P_p + P_t = P_p + K \cdot \frac{\eta VL}{s^2}$$

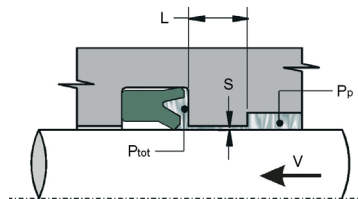

where

- $P_{tot}$  • total pressure
- $P_p$  • hydraulic pump's pressure
- $P_t$  • drag pressure
- K • constant factor (≈ 5)
- η • fluid's viscosity
- V • speed
- L • length of the surfaces in relative movement
- s • distance between the surfaces

The drag pressure, especially in the case of close fittings, can sometimes be higher to that generated by the pump itself causing early damage to the seal.

During this exercise, the seal element can be subjected to continuous pressure variations that, even if for short periods, often reach very high intensity values.

Those additional loads, that must be held into consideration before choosing the right sealing system, expose the seal to a high operating stress.

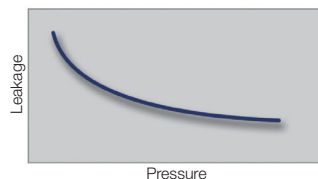

### Low pressure - less than 50 bar

Low pressure is the most critical situation for good performance of the sealing system and is the situation where it is possible to have more leakage problems.

In those cases, the sealing lips are not energized enough from the fluid and the oil film between lip and dynamic surface reaches an excessive thickness.

The choice of the right profile and material of the seal can remarkably reduce the leakage risk in this situation.

### Medium pressure - 50 ÷ 150 bar

The pressure range between 50 and 150 bar is one of the most favourable and, in this condition, almost all types of seals guarantee good sealing performance, even if with variable life depending on the material of the seal.

### High pressure - over 150 bar

With high pressure conditions or in presence of high peaks (shock loads), the seals normally give very good results: it is the fluid pressure itself that energizes the sealing lips therefore guaranteeing very good sealing performance. High pressure on the contrary reduces the entire sealing system's life. In these working conditions, we find lots of wear and extrusion cases that cause early damaging to the seals. So the choice of materials becomes very important as they must be very resistant to extrusion and wear.

# Mechanics of sealing

## Speed

The velocity between seal and moving surface is a critical factor to be considered on the choice of the seal and it has an important influence on the sealing system performance.

The leakage can be considered as proportional to the square root of the speed (see chapter "Mechanics of sealing") although it cannot be predicted in exact terms because it depends on so many factors starting with a suitable choice of seal for the job, type of fluid, temperature and surface quality.

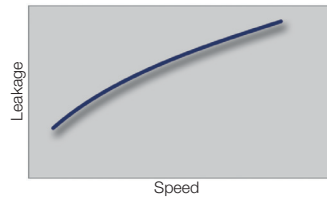

### Low speed - less than 0,05 m/s

In the situation of low speed, there aren't generally leakage problems although the inconveniences of rapid wear and irregular movement ("stick-slip") can happen with good chances. In the low speed range, hydraulic pressure generated by motion is not generally sufficient to create a continuous film of fluid and the sealing lip comes into direct contact with the sliding surface giving rise to rapid wear and irregular movement. The "stick-slip" phenomenon, in particular, is a noisy juddering motion caused by a constant repeating of holding and sliding between seal and sliding surface.

The correct choice of seal profile and material (ex. PTFE, with low friction coefficient) can reduce the problem and also improves the fluid and speed control.

### Medium speed - 0,05 ÷ 0,3 m/s

This is the best situation where there are neither irregular

movements, nor excessive losses typical of high speed. In these conditions, the hydraulic pressure generated by motion is able to guarantee a continuous film of fluid between sealing lip and sliding surface ensuring an accurate fluid control and the right lubrication of the seal.

The thickness of the film of fluid, proportional to the square root of the speed, does not generally reach the thicknesses liable to cause undesirable leakages.

### High speed - over 0,3 m/s

As the hydraulic pressure generated by motion increases, the seal is lifted off the sliding surface thus allowing an excessive thickness of fluid to pass. The situation becomes particularly critical when low pressure phases are associated with the high speed. In this case the seal is exclusively subjected to assembly deformation and, under such conditions, high modulus materials show their superiority by ensuring a high loading even in the absence of pressure.

## Temperature

The system temperature is a critical factor to be considered on the choice of materials and has an important influence on the extent of losses.

As a consequence of friction, the temperature on the sealing lips is generally higher than the system temperature, although it cannot be predicted in exact terms because it depends on many factors starting with the material, profile of the seal, type of fluid and surface quality.

Since the fluid viscosity is inversely proportional to temperature, the leakage can be considered as proportional to the square root of the inverse of temperature (see chapter "Mechanics of sealing"):

$$\text{leakage} \propto \sqrt{\frac{1}{T}}$$

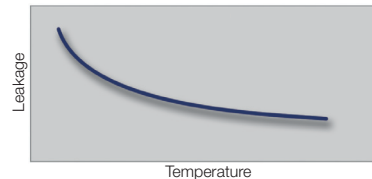

### Low temperature

When viscosity of the fluid grows, hardness of the sealing material increases and the seal loses elasticity thus allowing an excessive thickness of fluid to pass.

### Medium temperature

This is the best situation where the fluid has suitable viscosity to prevent losses through sufficient lubrication and the shape variations of the seal due to thermal expansion and variations in hardness don't decisively influence sealing system performance.

### High temperature

The sealing material becomes more elasticised, the volume of the seal increases and the viscosity of the fluid decreases thus reducing losses. However, at the same time, the insufficient lubrication increases the wear and the risk of irregular movements.

# Mechanics of sealing

## Friction

The friction between a dynamic seal and the sealing surface depends on a number of factors such as seal design and material, fluid, pressure, temperature, rubbing speed and surface finish. The frictional load resulting may not be significant in many applications (except in pneumatic cylinders where minimum friction is desirable for optimum performance), but friction itself can be harmful in generating heat which can cause degradation to the seal material and lubricant film and/or increase leakage by lowering viscosity. Degradation is more significant since this can yield abrasive products further contributing to friction and wear.

Seal performance in this respect is difficult to analyse in general terms since a number of empirical factors are involved, specific to the design of seal. However, as a basis, friction is obviously proportional to the pressure, although the co-efficient of friction involved may change with speed, temperature, material and surface finish.

$$\text{Seal Friction} = K \cdot \mu \cdot (P_e)^2 \cdot V \cdot A$$

where

- K • empirical factor specific to the design of seal installed and working under design conditions
- $\mu$  • coefficient of friction
- $P_e$  • equivalent pressure equal to the interference pressure plus the fluid pressure
- V • speed
- A • surface seal face contact  
( $\approx \pi \cdot \text{Diameter} \cdot \text{RadialSection}$ )

Specific values of K factor are difficult to obtain unless evaluated on empirical lines or on the basis of comparative data. This formula can only be used directly to investigate possible differences in performance and friction on compression seals of the same type and material, but different size.

### Friction coefficient “ $\mu$ ”

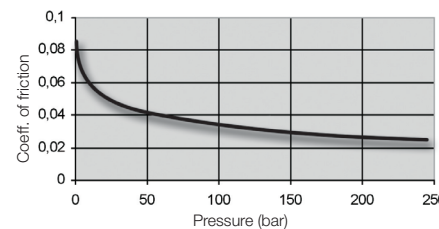

The dry friction of typical seal materials rubbing on a smooth, dry seal surface may be anything from  $\mu=0.4 \div 1$ . For lubricated surfaces the range is much lower, for example,  $\mu=0.02 \div 0.10$ . This is particularly true in the case of elastomers. Fabric materials and impregnated fabrics show similar values of “ $\mu$ ” but usually with less variation, for example  $\mu=0.04 \div 0.08$  for lubricated conditions.

In general, the harder the material the higher the friction, and the softer the material the lower the friction, although this only holds good at low pressure.

The coefficient of friction “ $\mu$ ” is also a function of pressure, although the actual relationship is not clearly established. Basically friction will be highest at low pressure, with a minimum value achieved at some high pressures (see figure).

The variation of friction with pressure is also dependent on the surface finish, and particularly the production method in the case of cylinders and piston seals. The more rapid increase in friction with increasing working pressure is marked with the rougher surface and texture of a cold hammered finish, compared with honed or burnished tubes.

Conventional cylinder finishes are produced by honing, resulting in a precisely controlled surface, having an average roughness of between  $0.25 \mu\text{m}$  and  $0.625 \mu\text{m}$ . The biggest problem for the seal designer, however, has been caused by the recent tendency to use hydraulic cylinders

produced directly from an “as-drawn” tube, without subsequent finishing treatment.

### Friction and speed

The variation of friction with rubbing speed is more clearly defined and follows three stages (see figure):

- static friction (direct contact between seal and dynamic surface)
- mixed friction (a mixed dry and liquid friction)
- liquid friction (a lubrication film of fluid between seal and dynamic surface)

At start up, the friction is high because it must get over the static friction coefficient [area 1].

Then, when the speed increases, a film of fluid interposes between seal and dynamic surface reducing the touching surface and thus the friction [area 2].

With a further speed rise the touching surface disappears and the friction, due to the shearing stresses of the fluid, increases [area 3].

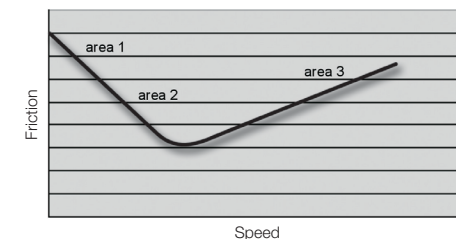

# Mechanics of sealing

## Wear and seal life

Because of their differing designs, and because they are produced from different materials, sealing systems have varying behaviour patterns at increasing operating pressures.

When a hard material is used the danger of damage by compression is reduced. On the other hand, a hard material does not have such good sealing characteristics as a soft material, particularly at low operating pressures.

For the best sealing system, effective at high and low operating pressures, a seal constructed from several types of material with different properties is needed. The ideal would be a solid seal made from several materials, having an increasing hardness and reaching a maximum hardness in the rear section of the seal space, where a gap occurs.

However, it is not practicable to achieve this fully although our designs of seals are constructed on a multi-stage principle in an attempt to approach the ideal.

Seals lose their ability to function because of normal wear to the seal material. This is greatest at the instant of starting and at low speeds, and also through erosion of the seal material when the pressurizing fluid flows over the

sealing surface and impinges on an area of deterioration. The first indication is seen at low pressure when, because of wear, the seal is no longer capable of maintaining the required contact with the sealing surface. At high pressure, because the deformation is greater, sealing may continue to be adequate so long as the pressure is maintained. The life of a seal cannot be predicted in exact terms because it depends on many factors starting with a suitable choice of seal for the job and correct installation. Wear can then be aggravated by lack of lubrication, shaft irregularities, excessive frictional heat, a seal compound which is too soft, ect. The normal life expectancy of seals will also vary considerably from one application to another as acceptable conditions and even the type of seal recommended differ widely.

If the life of a seal is significantly less than average for a particular application, then it is probable that an unsuitable seal was chosen in the first place and that the operating conditions turned out to be more severe than was expected when the seal was chosen.

Seal wear is heavily dependent on the finish of the surface against which the seal rubs, this in turn being determined,

to a large extent, by the production method.

The figure illustrates this for typical hydraulic cylinders with three different finishes. Seal wear here is graded visually from 0 for no apparent wear, to 10 for a worn out seal. These particular figures were taken after 100.000 cycles of cylinder operation at a working pressure of 250 bar.

A significant factor relative to the above is that with the burnished tube seal wear was largely unaffected by surface finish throughout the range 0.08  $\mu\text{m}$  to 0.7  $\mu\text{m}$ ; but rather more so in the case of cold hammered tubes with surface ranging from 0.4  $\mu\text{m}$  to 1.25  $\mu\text{m}$ .

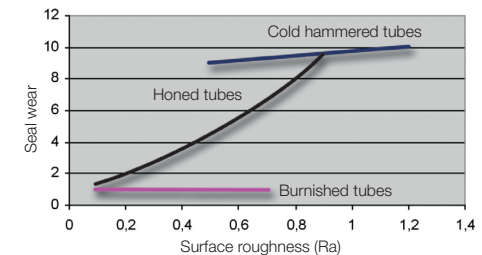

# Materials

## Hardness

In general terms materials with low hardness (softer materials) are more flexible and thus seal more readily on rougher surfaces or have better conformity, although they are more susceptible to wear, abrasion and extrusion.

A decrease in hardness can also be expected to reduce breakout friction with dynamic seals but running friction is reduced with increasing hardness (provided the unit surface load is reduced by reducing the squeeze). Basically, a higher hardness figure should give lower rubbing friction in any dynamic seal, although this depends specifically on adjusting the squeeze to compensate. Retain-

ing the same squeeze and increasing the hardness of the elastomer can increase both the breakout friction and the running friction.

Standard measurement of elastomer hardness are: **IRHD** (International Rubber Hardness Degrees), **BS** (British Standard) degrees and **Shore A** Durometer. The first two are identical, however, Shore A Hardness may be measured as an instantaneous reading or as a 30 second reading. In the former case the value obtained is about 5 degrees higher than IRHD.

The hardness of any elastomer can be modified by com-

pounding. Hardness is thus a control factor in the formulation of an elastomer for specific applications.

Hardness values used for seal materials may range from as soft as 40 to 50 °ShA up to a very hard compound of 95 °ShA hardness.

Hardness (and therefore friction) is also affected by swelling. Swelling tends to reduce hardness and at the same time will increase the squeeze. Similarly, hardness is affected by temperature, decreasing with increasing temperature, and vice versa. At the same time the squeeze is modified by the expansion or contraction of the seal.

## Elastic recovery

Elastic recovery, or resilience, is a measure of the ability of an elastomer to return to its original shape when a compression load is removed. Ideally a seal should have a good resilience which can be largely controlled by compounding. It is a peculiarity of many elastomers, however, that resilience can vary widely with temperature, and with a sharply defined minimum value which commonly occurs in the range of -20 to +20 °C. Some elastomers, notably silicones, retain substantially constant resilience over a wide range of temperatures.

A low rating is desirable for dynamic seals, where recovery

is important; this may refer to **compression set** or tension set and is a measure of the permanent change in original dimension after being compressed, or stretched, under compressive or tensile loading, respectively.

**Compression set** is significant in that because most seals are loaded in compression some permanent reduction in dimension or shrinkage will occur, by the amount of set characteristic for that material. This may, however, be offset by other factors, such as swelling of the seal in contact with the fluid or can be allowed for in seal design.

Excessive **tension set** may result in a seal ring being a lo-

ose fit after being stretched in place over a rod because the seal does not recover to its original inside diameter to which the groove was matched. This would probably be offset by compression set on completion of the assembly and so tension is normally ignored. The latter may be significant in plastomers which have low elongation and slow recovery, particularly if over-stretched. Both elastomers and plastomers, however, if loaded in tension, or with residual tensile stresses, will tend to contract with an increase in temperature.

# Materials

## Elastic modulus

Elongation is a reciprocal indication of material stiffness. It is defined as the increase in length as a percentage of the original length which, for the ultimate case, is the elongation at the point of breaking. Elongation is also used to define an elastomer that is a material capable of 100% elongation. Permissible elongation (the percentage stretch which can be applied without permanent damage or permanent set) determines the amount by which a ring seal can be stretched to fit in place. The term modulus is also used in connection with elongation and is generally taken to refer to the modulus (in tension) or the stress produced in the material at a pre-determined elongation, for example, 100 % elongation. This can be used as a measure of quality control. Modulus can also refer to stress per specified distortion in shear and compression (modulus in shear and modulus in compression, respectively). A change of modulus of a material indicates a change in material characteristics, a loss of modulus, for example, indicates a degradation of the product.

As a general safety rule elastomers seals should not permanently stretched more than about 5% as otherwise the resulting residual stresses can cause early deterioration further accelerated by any rise in temperature. This applies particularly to the more generally used elastomers such as Nitrile and natural rubbers. Some elastomers, notably ethylene-propylene, can accommodate a relatively high amount of permanent stretch with no adverse effects.

## Tensile strength

Tensile strength is a measurement of the mechanical strength of the material and in the case of elastomers can be taken as a general indication of resistance to deterioration under stress, for example wear and cracking. However, there is no direct relationship between tensile strength and wear resistance. Other factors, such as roughness of the surface against which the seal rubs, and service temperature, can be more significant in practice. The tensile strength of elastomers is generally low to moderate, polyurethane rubbers being the exception (see figure). Tensile strength also degenerates with increasing temperature. The actual value of tensile strength is not normally of critical importance in seals except those materials with a strength below 70 kg/cm<sup>2</sup> may not be suitable for dynamic seals.

derate, polyurethane rubbers being the exception (see figure). Tensile strength also degenerates with increasing temperature. The actual value of tensile strength is not normally of critical importance in seals except those materials with a strength below 70 kg/cm<sup>2</sup> may not be suitable for dynamic seals.

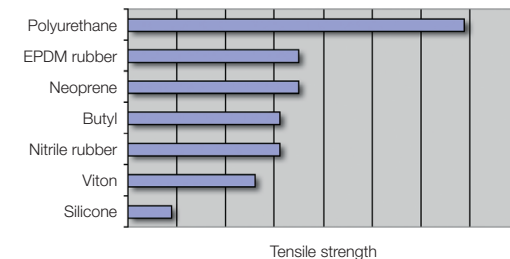

## Abrasion resistance

This is an important parameter as far as dynamic seals are concerned, but difficult to assess other than on purely empirical lines. Experience shows that certain materials such as natural rubber, polyurethane and leathers, have outstanding resistance to abrasion, while others, such as silicone rubbers, may have poor characteristics in this respect. In general, as far as elastomers are concerned, abrasion resistance generally improves with increasing hardness for particular basic elastomer and may be further enhanced by compounding. Good abrasion resistance is also often allied to high tear resistance, and vice versa.

hardness for particular basic elastomer and may be further enhanced by compounding. Good abrasion resistance is also often allied to high tear resistance, and vice versa.

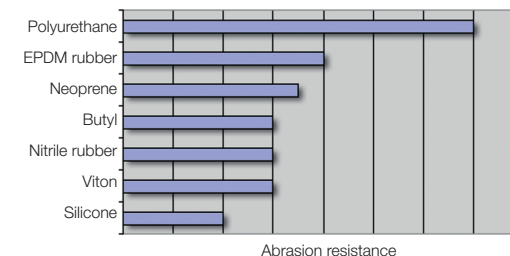



# Materials

## Tear resistance

In general tear resistance tends to be moderate to low with elastomers and high with fabricated materials or leather. The higher the tear resistance, the less likelihood of

a seal failing should it be accidentally scratched or nicked, as may happen during fitting. Such materials with low tear resistance need particular care in handling and fitting to

avoid all possibility of such damage occurring.

## Operating temperature

The operating temperature of a seal is a vital factor because any substantial difference between this and normal ambient temperature will normally modify the material characteristics, particularly in the case of elastomers.

The changes which occur at low temperatures are quite different from those produced by elevated temperatures. With decreasing temperature the tendency is for all elastomers to become progressively harder with loss of flexibility and slower recovery from deformation. Hardness/temperature curves in themselves do not give any particularly useful information as hardness may reach a nominal or actual maximum value while the material still retains good flexibility.

Direct measurement of flexibility or torsional stiffness is much more significant, and if this is plotted against temperature it will show a curve with a characteristic bend, for example T2 point. From this it can be determined the freeze point where a marked loss of flexibility starts.

Beyond the freeze point stiffness increases very rapidly with further decreases in temperature until the brittle point is reached, that is, the material becomes brittle and will break if flexed.

For design purposes the freeze point can be determined as the temperature at which the original stiffness (at 20°C) is doubled (x2 freeze point). The freeze point equivalent to an increase in stiffness to ten times the original may also be given (x10 freeze point) as a close indication of the temperature at which the material becomes quite unusable for flexing and is rapidly approaching the brittle condition. The x2 freeze point represents a safe minimum

temperature for working.

With certain elastomers a decrease in temperature may promote definite crystallization of the material in addition to normal stiffening. This may build up slowly, or even be localized to give a flat spot on the seal. The material may well be still useable under such conditions, due to the fact that it is nowhere near its brittle point, when in such cases the necessary resilience can be provided by spring loading if there is no immediate or economic choice of an alternative elastomer.

For any basic elastomer, low temperature characteristics can be modified to some extent by compounding. Thus an increase in hardness will usually lower the brittle point but make the material less flexible generally, whilst improvements in chemical resistance will often raise the brittle point.

It should also be emphasised that laboratory tests on the material alone at low temperature will not necessarily be characteristic of the material performance in service as a seal. This is largely because the fluid in contact with the seal can affect the degree of plasticization; it can be absorbed, for instance, and increase the effective degree of plasticization, or leach out a proportion of the original plasticizer. Control of these effects is largely a matter of compounding, although compatibility with the fluid may be a prior requirement, in which case it may be necessary to sacrifice some low temperature performance.

At elevated temperatures, all elastomers lose strength and thus tend to become softer and more flexible. Normally recovery is complete on reduction of temperature,

but if the temperature is high enough some changes may be permanent. Also ageing characteristics are accelerated by heat, normally taking the form of a progressive increase in hardness and modulus with loss of elastomeric properties.

A further important effect which may have to be considered when the operating temperature of the seal differs substantially from normal room temperature is the relative thermal expansion or contraction of the seal and its surrounds. The thermal coefficient of expansion is much higher than that of metals (roughly ten times that of steel). This is normally most significant at elevated temperatures where thermal expansion of the seal is substantially greater than that of its surrounds and actual volumetric expansion may be further increased by swelling in contact with the fluid.

Material	Service temperature range	
	Min. [°C]	Max [°C]
Butyl rubber (IIR)	-40	+150
Ethylene propylene diene rubber (EPDM)	-50	+150
Hydrogenated acrylonitrile butadiene rubber (HNBR)	-25	+150
Nitrile rubber (NBR)	-30	+110
Phenol formaldehyde (PF)	-40	+120
Polyacetal (POM)	-40	+110
Polytetrafluoroethylene (PTFE)	-200	+200
Polyurethane (TPU)	-40	+100
Silicone rubber (MQ)	-60	+230
Viton (FKM)	-30	+200



## Materials

### Thermoplastic polyurethane [TPU]

Name	<b>SEALPUR</b>
Hardness	SEALPUR 93 → 93 °ShA SEALPUR 94 → 94 °ShA SEALPUR 97 → 97 °ShA
Working temperature	- 40 ÷ +100 °C
Physical characteristics	<ul style="list-style-type: none"> <li>• Strength → very high</li> <li>• Resilience → good</li> <li>• Resistance to abrasion → excellent</li> <li>• Resistance to ageing/weathering → medium</li> </ul>
Fluid/chemical resistance	<ul style="list-style-type: none"> <li>• Resistant to mineral oils and greases</li> <li>• Not resistance to automotive brake fluids, water or acids</li> </ul>

Polyurethane is one of the more recently developed elastomers with exceptional strength, tear and abrasion resistance (better than all other rubbers) and retaining excellent flexibility at low temperatures.

It is an organic material of high molecular weight whose chemical composition is characterised by a large number of urethane groups. The composition of the material is determined by three components: polyol, diisocyanate and chain extender. The type and amount of these materials used, and the reaction conditions, are decisive in determining the properties of the resulting polyurethane material.

Resistance is good to petroleum products, hydrocarbons, ozone and weathering. Performance is generally unsatisfactory in contact with aqueous solutions of an acid or alkaline nature, chlorinated hydrocarbons, ketones, hot water, steam or glycol.

Polyurethane rubbers are, therefore, most attractive from the point of view of their mechanical strength rather than chemical or temperature properties. They may be used to advantage, if compatible, under abrasive conditions (particularly for wipers).

### Acrylonitrile Butadiene Rubber [NBR]

Name	<b>RUBSEAL</b>
Hardness	RUBSEAL RUBSEAL 70 → 70 °ShA RUBSEAL 75 → 75 °ShA
Working temperature	- 30 ÷ +110 °C
Physical characteristics	<ul style="list-style-type: none"> <li>• Strength → medium</li> <li>• Resilience → medium</li> <li>• Resistance to abrasion → medium</li> <li>• Resistance to ageing/weathering → medium</li> </ul>
Fluid/chemical resistance	<ul style="list-style-type: none"> <li>• Resistant to mineral oils and greases, water and many other chemicals, hydrocarbon fuels, etc.</li> <li>• Not resistance to non-mineral automotive brake fluids</li> </ul> <p><small>note: increase in acrylonitrile content improves resistance to mineral oil but adversely affects low temperature resistance</small></p>

Nitrile rubbers form the most important group of elastomers for general sealing use.

Chemically, Nitrile is a copolymer of butadiene and acrylonitrile content, typically varying between about 18% and 48%. Nominal designations are low, medium and high Nitrile. Resistance to petroleum based oils and hydrocarbons increases with increasing Nitrile content, but at the same time low temperature flexibility decreases. In order to obtain good low temperature performance with Nitrile rubbers it usually necessary to sacrifice some high temperature fuel and oil resistance.

Nitrile rubbers have good physical characteristics and are superior to most other rubbers. They are not particularly resistant to ozone, weathering and sunlight, but their properties in this respect can be improved by compounding. Due to their susceptibility to ozone attack Nitrile rubber seals should not be stored near any possible source of ozone (ex. near an electric motor or electrical equipment), or in direct sunlight.

### Polytetrafluoroethylene [PTFE]

Name	<b>SEALFLON</b>
Working temperature	- 200 ÷ +200 °C
Physical characteristics	<ul style="list-style-type: none"> <li>• Strength → medium</li> <li>• Resilience → medium</li> <li>• Resistance to abrasion → medium</li> <li>• Resistance to ageing/weathering → excellent</li> </ul>
Fluid/chemical resistance	The resistance to swelling is good in almost all media. The chemical resistance exceeds that of all other thermoplastics and elastomers.

Polytetrafluoroethylene (PTFE) is a polymer of tetrafluoroethylene.

This non-elastic polymeric material can be used as support member with an elastomeric seal.

It is characterised by a series of outstanding properties: the coefficient of friction is very low against most opposing surfaces made of other materials; the chemical resistance exceeds that of all other thermoplastics and elastomers, thus the resistance to swelling is good in almost all media (liquid alkali metals and a few fluorine compounds attack PTFE at higher temperatures and pressures); it is non-toxic at working temperatures up to + 200 °C; the surface is slippery and repels most media, its use is favoured in all cases where the retention of residues is to be avoided; the electrical insulating properties are outstandingly good, they are almost independent of frequency, temperature and weathering effects.

The Temperature range for use is between -200 °C and + 200 °C. Even at - 200 °C, PTFE still has some elasticity and therefore it can be used for seals and constructional parts, for example, with liquified gases.

When using parts of pure PTFE, the following points should be noted: that above a certain level of stress, the material continues to deform due to creep or cold flow; that the abrasion resistance is low; that thermal expansion

# Materials

sion, like most plastics, is about 10 times that of metals; that the thermal conductivity is low so that removal of heat from bearings and from other moving seals can lead to problems; that the material is not elastomeric but is hard like polyethylene.

The latter can present problems in fitting, such as stretching the ring sufficiently to locate in their grooves. Recovery from stretch will also be slow, so that assembled rings will have to be left for a considerable period before they recover their original size, although this process of recovery can be accelerated by gentle heating.

For these reasons, elastomeric seals in assemblies cannot simply be replaced by PTFE seals. With lip seals, provision must be made for a constant additional contact pressure by the use of springs or by other means.

PTFE is filled with graphite, glass fibres, bronze and carbon to achieve special properties.

## Thermoplastic polyester resin [TPE-E]

Name	<b>SEALITE</b>
Hardness	SEALITE 55 → 55 °ShD SEALITE 63 → 63 °ShD
Working temperature	- 40 ÷ +140 °C
Physical characteristics	<ul style="list-style-type: none"> <li>• Strength → very high</li> <li>• Resilience → high</li> <li>• Resistance to abrasion → outstanding</li> <li>• Resistance to ageing/weathering → excellent</li> </ul>
Fluid/chemical resistance	Resistant to solvents, hydrocarbon fluids including petrol and lubricating oils

Thermoplastic polyester resin is a medium modulus material mainly used in the manufacturing of antiextrusion rings to support sealing elements.

It provides a winning combination for many parts and components: it gives the flexibility of rubbers, the strength of plastics, and the processibility of thermoplastics.

It provides an extra measure of performance and service life in application where properties such as abrasion re-

sistance and tear strength are critical. It provides better performance in low temperature environments keeping its good properties ("creep", impact resistance, fatigue life) at high temperature.

Its chemical properties make it highly resistant to hydrocarbons and many other fluids.

## Acetal resin [POM]

Name	<b>BEARITE</b>
Working temperature	- 40 ÷ +110 °C
Physical characteristics	<ul style="list-style-type: none"> <li>• Strength → very high</li> <li>• Resistance to abrasion → excellent</li> <li>• Resistance to ageing/weathering → good</li> </ul>
Fluid/chemical resistance	<ul style="list-style-type: none"> <li>• Resistant to gasoline, moisture, lubricating oils, solvents and many other neutral chemicals</li> <li>• Not resistance to strong acids or bases outside the range of pH 4 to 9, under constant exposure to pressurised hot water or vapour</li> </ul>

Acetal resin with glass fibre is a high modulus material mainly used in the manufacturing of wear rings or antiextrusion rings (with glass fibre).

Acetal resins are made by the polymerisation of formaldehyde. The homopolymer offers significantly better mechanical properties than copolymer due to the highly crystalline structure of the acetal homopolymer.

They have built up a worldwide reputation for reliability in engineering components.

They are characterised by a series of outstanding properties: high tensile strength, impact resistance and stiffness; good fatigue resistance, unmatched by other plastics; excellent dimensional stability; "creep" resistance; low friction; wide working temperature range, down to very low temperatures.

The low water absorption is especially significant because better dimensional stability in humid conditions is thus guaranteed, even when compared with polyamide.

## Phenol-Formaldehyde [PF]

Name	<b>PHENOLITE</b>
Working temperature	- 40 ÷ +130 °C
Physical characteristics	<ul style="list-style-type: none"> <li>• Strength → excellent</li> <li>• Resilience → excellent</li> <li>• Resistance to abrasion → excellent</li> <li>• Resistance to ageing/weathering → good</li> </ul>
Fluid/chemical resistance	Resistant to mineral oils, greases, organic solvents, weak acids and alkalis, and saline solutions

Phenol-Formaldehyde is a high modulus material mainly used in the manufacturing of wear rings.

It is a synthetic resin formed from the elimination reaction of phenol with formaldehyde.

It is characterised by a series of outstanding properties: excellent resistance to loads; high tensile strength, extended service life, low friction, wear-resistance, impact resistance and stiffness; "creep" resistance; flame retardant; wide working temperature range from -40°C to +120°C; excellent dimensional stability and accuracy of thickness.

For short periods can tolerate temperatures up to +300°C. At normal temperature phenol is pale yellowish; the colour stability of phenol is decreased by the effects of light, air and iron oxides during storage.

Due to its chemical structure it is not suitable for use with foodstuffs.

# Materials

## Ethylene-Propylene [EPDM]

Working temperature	- 50 ÷ +150 °C
Physical characteristics	<ul style="list-style-type: none"> <li>• Strength → medium</li> <li>• Resilience → medium</li> <li>• Resistance to abrasion → medium</li> <li>• Resistance to ageing/weathering → good</li> </ul>
Fluid/chemical resistance	<ul style="list-style-type: none"> <li>• Resistant to non-mineral oils, automotive brake fluids, phosphate ester fluid, water/steam and many chemicals</li> <li>• Not resistance to mineral oils and grease or hydrocarbon fuels</li> </ul>

Ethylene-Propylene is one of the best general-purpose synthetic rubbers. Polymerisation and catalyst technologies in use today provide the ability to design polymers to meet specific and demanding application and processing needs. EPDM rubbers are valuable for their excellent resistance to heat, oxidation, ozone and weather-ageing due to their stable, saturated polymer backbone structure. Compression set resistance is good, particularly at high temperatures. They have a good resistance to polar solvents such as water, acids, alkalies, phosphate ester and many ketones and alcohols.

## Fluoroelastomer [FKM]

Trademark name	<b>VITON</b>
Working temperature	- 30 ÷ +200 °C
Physical characteristics	<ul style="list-style-type: none"> <li>• Strength → medium</li> <li>• Resilience → poor</li> <li>• Resistance to abrasion → poor</li> <li>• Resistance to ageing/weathering → excellent</li> </ul>
Fluid/chemical resistance	Excellent resistance to mineral oils and hydrocarbon fuels. Resistant to many chemicals except ketones, alcohols and acids

Fluoroelastomer rubber, well known for its excellent heat resistance (200 °C), offers excellent resistance to aggressive fuels and chemicals

Many types of Fluoroelastomer rubbers have been developed to meet specific end-use and processing needs. There are differences between rubber types in terms of chemical resistance and mechanical properties. The general purpose types differ primarily from the specialty types in chemical resistance.

The formulation of fluoroelastomer rubbers, can be tailored to a reasonable extent to meet the needs of high heat, oil and chemical resistance but indifferent low temperature performance.

They are one of the most resistant to high temperatures of all of the commercially available elastomers.

## Silicone [MQ]

Working temperature	- 60 ÷ +230 °C
Physical characteristics	<ul style="list-style-type: none"> <li>• Strength → poor</li> <li>• Resilience → medium</li> <li>• Resistance to abrasion → poor</li> <li>• Resistance to ageing/weathering → excellent</li> </ul>
Fluid/chemical resistance	<ul style="list-style-type: none"> <li>• Resistant to mineral oils and greases</li> <li>• Not resistant to water, acids and non-mineral automotive brake fluids</li> </ul>

Basically, silicones have poor strength and tear and abrasion resistance, although mechanical performance can be enhanced by special compounding. Resistance is generally good to alkalis; the chemical properties can be enhanced by special compounding to provide better resistance to oils and fuels for instance. In general, however, silicone rubbers are not recommended for use with hydrocarbons such as petrol and paraffin, the lighter minerals or steam at high pressure as otherwise considerable swelling and softening of the elastomer can result.

The chief advantage of this type of elastomer is that it retains its flexibility down to very low temperatures, and

can also withstand continuous heating at high temperatures without hardening, making it suitable for both high and low temperature seals over a broader range than that covered by the other elastomers. A further application is for high speed seals (ex. rotary seals) where the operating temperatures may be higher than that permissible with conventional elastomers due to the friction developed, where again a silicone rubber may provide an answer. The cost of silicone rubber is, however, substantially higher than that of the most other elastomers.

## Fluorosilicone [FMQ]

Working temperature	- 50 ÷ +200 °C
Physical characteristics	<ul style="list-style-type: none"> <li>• Strength → poor</li> <li>• Resilience → medium</li> <li>• Resistance to abrasion → poor</li> <li>• Resistance to ageing/weathering → excellent</li> </ul> Typical working values depend on compound formulation
Fluid/chemical resistance	Good resistance to mineral oils, greases and hydrocarbon fuels

Working characteristics of fluorosilicone rubbers are generally similar to those of ordinary silicone, but with a more restricted service temperature range. The main advantage offered is that fluorosilicone rubbers can have an oil resistance comparable with or closely approaching that of Nitrile rubbers. They can thus be used for the service temperature limits of nitrile rubbers and where ordinary silicone elastomers do not have necessary compatibility with the fluid.

# Materials

## Polychloroprene [CR]

Common name	<b>NEOPRENE</b>
Working temperature	- 30 ÷ +80 °C
Physical characteristics	<ul style="list-style-type: none"> <li>• Strength → medium</li> <li>• Resilience → medium</li> <li>• Resistance to abrasion → medium</li> <li>• Resistance to ageing/weathering → very good</li> </ul>
Fluid/chemical resistance	<ul style="list-style-type: none"> <li>• Moderate resistance to mineral oils and greases</li> <li>• Not resistant to non-mineral automotive brake fluids</li> </ul>

Polychloroprene is one of the best general-purpose synthetic rubbers, although its use in seal applications is somewhat limited at the present time. Its main advantage is its excellent resistance to weather-ageing. It is also superior to natural rubber in performance at higher temperatures, but tends to harden or stiffen at low temperatures and may also crystallize at low temperature if under stress. This tendency can be reduced by the correct choice of polymer type and by compounding.

## General properties of the common elastomers

Rating guide	IIR <i>butyl</i>	EPDM <i>ethylene-propylene</i>	FKM <i>viton</i>	FMQ <i>fluoro-silicone</i>	CSM <i>hypalon</i>	FFKM <i>kalrez</i>	CR <i>neoprene</i>	NBR <i>nitrile rubber</i>	TPU <i>polyurethane</i>	MQ <i>silicone</i>	SBR <i>styrene-butadiene</i>	PTFE <i>teflon</i>
excellent	↑											
good	↗											
fair	→											
questionable	↘											
poor	↓											
<b>Economy</b>	→	↗	→	↓	→	↓	↗	↑	↑	→	↑	↓
<b>Temperature range °C</b>	-40 +150	-50 +150	-30 +200	-50 +200	-20 +120	-45 +300	-30 +80	-30 +110	-40 +100	-60 +230	-50 +100	-200 +200
<b>Tensile strength</b>	-	↗	→	↓	↗	→	→	↗	↑	↓	↗	→
<b>Elongation max. %</b>	800	600	300	600	500	150	600	600	500	800	600	250
<b>Hardness range °ShA</b>	40 80	40 90	50 95	50 80	50 90	65 95	40 90	40 90	40 94	25 80	40 90	98
<b>Resilience - Rebound</b>	↓	↗	→	↗	→	-	↑	↗	↑	→	↗	↓
<b>Compression set</b>	→	→	↗	↑	→	↗	→	↗	→	↑	↗	↓
<b>Adhesion to metals</b>	↗	→	→	↘	↑	-	↑	↑	→	↗	↑	↑
<b>Abrasion resistance</b>	→	↗	↗	↓	↑	-	↑	↗	↑	↓	↑	→
<b>Tear resistance</b>	↗	→	→	↘	→	-	↗	↗	↑	↓	→	↓
<b>Weather resistance</b>	↑	↑	↑	↑	↑	-	↑	↘	↗	↑	↓	↑
<b>Ozone resistance</b>	↑	↑	↑	↑	↑	-	↑	↓	↑	↑	↓	↑
<b>Water swell resistance</b>	↑	↑	↗	↑	→	↑	→	↗	↓	↑	↑	↑
<b>Steam resistance</b>	↗	↑	↓	↓	↓	↑	↓	↓	↓	↘	↓	-
<b>Gas impermeability</b>	↑	→	↑	↓	↗	-	↑	↑	↑	↓	→	↗
<b>Acid resistance</b>	↑	↗	↑	↗	↑	↑	→	↗	↓	→	→	↑
<b>Alkali resistance</b>	↑	↑	→	→	↑	↑	↑	↗	→	↑	→	↗
<b>Alcohols</b>	↑	↑	→	↗	↑	↑	↑	↑	↓	↑	↑	↑
<b>Mineral oils</b>	↓	↓	↑	↑	→	↑	↗	↑	↗	↗	↓	↑
<b>Aliphatic hydrocarbons</b>	↓	↓	↑	→	→	↑	→	↑	→	↓	↓	↑
<b>Aromatic hydrocarbons</b>	↓	↓	↑	→	↘	↑	↓	↓	→	↓	↓	↑
<b>Halogenated hydrocarb.</b>	↓	↓	↑	↘	↘	→	↓	↘	→	↓	↓	↑
<b>Phosphate ester</b>	↗	↑	↓	↘	↓	↑	↓	↓	↓	↓	↓	-
<b>Polar solvents</b>	↗	↑	↓	↓	↓	↑	↓	↓	↓	↓	↓	↑

# Materials

## Trademark names of the common materials

Trademark name	Chemical name	Symbol
Adiprene	Polyurethane	TPU
Alathon	Polyethylene	PE
Algoflon	Polytetrafluoroethylene	PTFE
Baylon	Polyethylene	PE
Baypren	Polychloroprene	CR
Breon	Acrylonitrile Butadiene	NBR
Breon	Polyvinyl chloride	PVC
Buna AP	Ethylene-Propylene	EPDM
Buna Hüls	Styrene-butadiene	SBR
Buna N	Acrylonitrile Butadiene	NBR
Buna SB	Styrene-butadiene	SBR
Butaclor	Polychloroprene	CR
Butacril	Acrylonitrile Butadiene	NBR
Butakon	Acrylonitrile Butadiene	NBR
Cariflex S	Styrene-butadiene	SBR
Carom	Styrene-butadiene	SBR
Chemigum	Acrylonitrile Butadiene	NBR
Chemraz	Perfluoroelastomer	FFKM
Crastin	Polybutylene terephthalate	PBTP
Cyanacryl	Acrylate rubber	ACM
Cycolac	Acrylonitrile-butadiene-styrene	ABS
Dai El	Fluoroelastomer	FKM
Delrin	Acetal resin	POM
Denkachloprene	Polychloroprene	CR
Desmopan	Polyurethane	TPU
Durethan	Polyamide	PA
Dutral	Ethylene-Propylene	EPDM
Dymetrol	Polyamide	PA
Elastothane	Polyurethane	TPU
Enjay butyl	Butyl	IIR
Epsyn	Ethylene-Propylene	EPDM

Trademark name	Chemical name	Symbol
Esso butyl	Butyl	IIR
Estane	Polyurethane	TPU
Europrene	Styrene-butadiene	SBR
Europrene AR	Acrylate rubber	ACM
Europrene N	Acrylonitrile Butadiene	NBR
Ferrozell	Phenol-Formaldehyde	PF
Fluon	Polytetrafluoroethylene	PTFE
Fluorel	Fluoroelastomer	FKM
Halon	Polytetrafluoroethylene	PTFE
Hostaflon	Polytetrafluoroethylene	PTFE
Hostaform	Acetal resin	POM
Hostalen	Polyethylene	PE
Hostalit	Polyvinyl chloride	PVC
Hostyren	Polystyrol	PS
Hycar	Acrylonitrile Butadiene	NBR
Hypalon	Chlorosulphonated polyethylene	CSM
Kalrez	Perfluoroelastomer	FFKM
Keltan	Ethylene-Propylene	EPDM
Krynac	Acrylonitrile Butadiene	NBR
Lexan	Polycarbonate	PC
Lupolen	Polyethylene	PE
Lustrex	Polystyrol	PS
Makrolon	Polycarbonate	PC
Neoprene	Polychloroprene	CR
Nipol	Acrylonitrile Butadiene	NBR
Nipol AR	Acrylate rubber	ACM
Nitriflex	Acrylonitrile Butadiene	NBR
Nordel	Ethylene-Propylene	EPDM
Novodur	Acrylonitrile-butadiene-styrene	ABS
Noxite	Fluoroelastomer	FKM
Noxite PA	Acrylate rubber	ACM

Trademark name	Chemical name	Symbol
Nylon	Polyamide	PA
Paracril	Acrylonitrile Butadiene	NBR
Pellethane	Polyurethane	TPU
Pertinax	Phenol-Formaldehyde	PF
Plaskon	Polyvinyl chloride	PVC
Pocan	Polybutylene terephthalate	PBTP
Polysar butyl	Butyl	IIR
Polysar EPDM	Ethylene-Propylene	EPDM
Rhodorsil	Silicone	MQ
Rilsan	Polyamide	PA
Royalene	Ethylene-Propylene	EPDM
Silastic	Silicone	MQ
Silicone	Silicone	MQ
Silopren	Silicone	MQ
Simputhan	Polyurethane	TPU
Simriz	Perfluoroelastomer	FFKM
Solprene	Styrene-butadiene	SBR
Tecnoflon	Fluoroelastomer	FKM
Teflon	Polytetrafluoroethylene	PTFE
Terluran	Acrylonitrile-butadiene-styrene	ABS
Ultradur	Polybutylene terephthalate	PBTP
Ultraform	Acetal resin	POM
Ultramid	Polyamide	PA
Urepan	Polyurethane	TPU
Vamac	Ethylene acrylate	AEM
Vestamid	Polyamide	PA
Vestodur	Polybutylene terephthalate	PBTP
Vestyron	Polystyrol	PS
Vistalon	Ethylene-Propylene	EPDM
Viton	Fluoroelastomer	FKM
Vulkollan	Polyurethane	TPU

## Shelf life

### Guidelines and recommendations for the storage of polyurethan and elastomer seals

During storage, the characteristics of the elastomers and of the products in plastic or polyurethane can be damaged by

- **chemical reactions** which are fundamentally caused by the influence of heat, light, oxygen, ozone, humidity and various chemical agents
- **physical process**

This physical process called “physical ageing”, is caused by the influence of external tensions, leading to cracks and permanent deformation, or by the migration of plasticizers from semi-finished products that make it more fragile and lead to deformation of the parts.

Therefore, the rubber and polyurethane products maintain their characteristics without major changes for many years if proper storage is guaranteed. In this case the properties of ageing and storage of these products depend heavily on their chemical structure.

Unsaturated elastomers such as nitrile rubber (NBR) can have much shorter shelf life in improper storage condi-

tions than, for example, saturated elastomers such as the fluoroelastomer (FKM).

The ideal characteristics of these products can be maintained for long periods of time only if the products are stored in accordance with the recommendations of DIN 7716.

### Storage conditions for elastomers and plastics materials

Rubber, plastic and polyurethane products should be stored in a cool, dry place. The storage temperature should be about 15 °C and not exceed 25 °C; relative humidity must be less than 65%.

Rubber, plastic and polyurethane products should not be exposed to direct sunlight and artificial light with a high content of UV.

The storage rooms should not contain any ozone-producing devices such as electric motors or high-voltage devices. It is also essential to protect the seals by hermetic packaging.

The contact between rubber products of different compositions should be avoided. As well as the contact with chemicals and/or hazardous metals (eg copper, manganese) is to be avoided.

The seals must be kept in a state of “tension-free”: the parts should not be subjected to tension, pressure or bending deformation.

If all these recommendations are met, the seals may be retained for the time periods specified below, without losing their characteristics:

Trade name	Material	Symbol	Storage
Sealpur	Polyurethane	TPU	about 12 years
Rubseal	Nitril Rubber	NBR	about 5 years
Seafion	Polytetrafluoroethylene	PTFE	about 12 years
Sealite	Resina Poliesterre	TPE-E	about 12 years
Bearite	Acetal resin	POM	about 10 years
-	Poliamide	PA	about 10 years
-	Ethylen-propylene	EPDM	about 8 years
-	Hydrogenated Nitrile Rubber	H-NBR	about 8 years
Viton	Fluoroelastomer	FKM	about 10 years
-	Silicone	MQ	about 10 years

*NOTE: The above instructions, recommendations and guidelines are listed according to our best knowledge. However, we can not offer any guarantee and/or responsibility in this regard.*



# Materials

## Most popular fluids compatibility table

Rating guide		Symbols guide	
excellent	↑	<b>NBR</b>	Nitrile rubber
fair (OK for static seals)	↗	<b>EPDM</b>	Ethylene-propylene
		<b>FKM</b>	Fluoroelastomer (Viton)
questionable (sometimes OK for static seals)	→	<b>CR</b>	Neoprene
		<b>FMQ</b>	Fluoro-silicone
poor	↓	<b>MQ</b>	Acetal resin
		<b>POM</b>	Polyurethane
		<b>TPU</b>	Polyester resin
		<b>TPE-E</b>	Polytetrafluorethylene
		<b>PTFE</b>	Politetrafluoretilene

Fluid	NBR	EPDM	FKM	CR	FMQ	MQ	POM	TPU	TPE-E	PTFE
Acetaldehyde	→	↗	↓	→	↓	↗		↓		↑
Air	↑	↑	↑	↑	↑	↑	↑	↑	↑	↑
Air-with oil mist	↑	↓	↑	↗	↑	↗	↑	↑	↑	↑
Ammonia	↗	↑	↓			↓	↓	↓		↑
Benzene / Benzol	↓	↓	↑	↓	→	↓	↓	↓		↑
Biodegradable polyglycol oil, HEPG	↓	↑	↑				↑	↓	↑	↑
Biodegradable synthetic ester oil, HEES	↓	↓	↑				↑	→	↑	↑

Fluid	NBR	EPDM	FKM	CR	FMQ	MQ	POM	TPU	TPE-E	PTFE
Biodegradable vegetable oil, HETG	↑	↓	↑				↑	→	↑	↑
Brake fluid	↓	↑	↓	→	↓	→	↑	↓		↑
Combustible oil	↗	↓	↑				↗			↑
Distilled water	↗	↗	↗					↓		↑
Ethyl alcohol	↗	↑	↗	↑	↑	↗	→	↓	↑	↑
Fuel ASTM A	↑	↓	↑	↗	↑	↓		↑		↑
Fuel ASTM B	→	↓	↑	↓	↑	↓		↓		↑
Fuel ASTM C	↗	↓	↑	↓	↗	↓		↓		↑
Fuel ASTM D	↑	↓	↑	→	↑	↓		→		↑
Fuel oil	↑	↓	↑	↗	↑	↓	→	↗	↑	↑
Gasoline	↗	↓	↑	↓	↑	↗	→	↗	↑	↑
Glycerine	↑	↑	↑	↑	↑	↑	↑	↓	↑	↑
Glycols	↑	↑	↑	↑	↑	↑	↑	↓	↑	↑
Grease, mineral	↑	↓	↑	→	↑	↓		↑	↑	↑
Houghto-Safe 1010	↓	↑	↑							↑
Houghto-Safe 1120	↓	↑	↑							↑
Houghto-Safe 620	↑	→	↑				↑	↓	↑	↑
Kerosene	↗	↓	↑	↗	↑	↓	↑	↑		↑

Fluid	NBR	EPDM	FKM	CR	FMQ	MQ	POM	TPU	TPE-E	PTFE
Methyl alcohol	↑	↑	↓	↑	↑	↑	↓	↓	↑	↑
Methyl ethyl ketone	↓	↑	↓	↓	↓	↓	↑	↓	→	↑
Oil ASTM #1	↑	↓	↑	↑	↑	↑	↑	↑	↑	↑
Oil ASTM #2	↑	↓	↑	↗	↑	↓		↓		↑
Oil ASTM #3	↑	↓	↑	↓	↑	→	↑	↗	↑	↑
Oil ASTM #4	↗	↓	↑	↓	↗	↓		↓		↑
Ozone	↓	↑	↑	→	↑	↑		↑		↑
Paraffin	↑	↓	↑	↑		↓	↑	→	↑	↑
Petroleum oil	↑	↓	↑	↗	↗	↗	↑	↑	↑	↑
Salt water	↑	↑	↑	↗	↑	↑	↑	↗	↑	↑
Soap solution	↑	↑	↑			↗	↑	↑		↑
Sodium hydroxide	↗	↑	↗	↗	↗	↑	↓	→	↑	↑
Steam	↓	↑	↗	↓	↓	→	↑	↓	→	↑
Toluene	↓	↓	↑	↓	↗	↓	↓	↓	→	↑
Water (above 50 °C)	→	↑	↑				↑	↓		↑
Water (below 50 °C)	↑	↑	↗	↗	↑	↑	↑	→	↑	↑
Water-glycol emulsion	↑	↑	↗	↗		↗	↑	↓	↑	↑
Water-oil emulsion	↑	↓	↑				↑	→	↑	↑



## Other fluids compatibility table

Rating guide		Symbols guide	
excellent	↑	<b>NBR</b>	Nitrile Rubber
fair (OK for static seals)	↗	<b>EPDM</b>	Ethylene-Propylene
		<b>FKM</b>	Fluorocarbon (Viton)
questionable (sometimes OK for static seals)	→	<b>TPU</b>	Polyurethane
		<b>HNBR</b>	Hydrogen. Nitrile Rubber
		<b>CR</b>	Neoprene
poor	↓	<b>FMQ</b>	Fluoro-Silicone
		<b>MQ</b>	Silicone
		<b>IIR</b>	Butyl
		<b>BR</b>	Butadiene
		<b>IR</b>	Isoprene
		<b>SBR</b>	Styrene-Butadiene
		<b>FFKM</b>	Perfluoroelastomer (Kalrez)
		<b>ACM</b>	Polyacrylate
		<b>PTFE</b>	Polytetrafluorethylene

Fluid	NBR	EPDM	FKM	TPU	HNBR	CR	FMQ	MQ	IIR	BR	IR	SBR	FFKM	ACM	PTFE
Abietic Acid													↑		
Acetaldehyde	↓	↗	↓	↓	↓	→	↓	↗	↗	↗	↗	↗	↑	↓	
Acetamide	↑	↑	↓	↓	↑	↑	↑	↗	↗	↓	↓	↓	↑	↓	↑
Acetanilide	→	↑	→	↓	→	↑	↑	↗	↑	↑	↑	↑	↑	↓	
Acetic Acid, 30%		↑											↑		
Acetic Acid, 5%	↗	↑	↑	↓	↗	↑	↗	↑	↑	↗	↗	↗	↑	↓	
Acetic Acid, Glacial	↗	↑	↗	↓	↗	↓	↑	↗	↗	↗	↗	↗	↑	↓	

Fluid	NBR	EPDM	FKM	TPU	HNBR	CR	FMQ	MQ	IIR	BR	IR	SBR	FFKM	ACM	PTFE
Acetic Acid, Hot, High Pressure	↓	→	↓	↓	↓	↓	→	↓	↓	↓	↓	↓	↑	↓	
Acetic Anhydride	↓	↗	↓	↓	↓	→	↓	↗	↗	↗	↗	↗	↑	↓	↑
Acetoacetic Acid	→	↑	→	↓	→	↑	↑	↗	↑	↑	↑	↑	↑	↓	
Acetone	↓	↑	↓	↓	↓	↓	↓	↓	↑	↓	↓	↓	↑	↓	↑
Acetone Cyanohydrin	→	↑	→	↓	→	↑	↑	↗	↑	↑	↑	↑	↑	↓	
Acetonitrile	→	↑	↑										↑		
Acetophenetidine	↗	↓	↑	→	↗	↓	↗		↓	↓	↓	↓	↑	↓	
Acetophenone	↓	↑	↓	↓	↓	↓	↓	↓	↗	↓	↓	↓	↑	↓	↑
Acetotoluidide	↗	↓	↑	→	↗	↓	↗		↓	↓	↓	↓	↑	↓	
Acetyl Acetone	↓	↑	↓	↓	↓	↓	↓	↓	↑	↓	↓	↓	↑	↓	
Acetyl Bromide	↓	↑	↑	↓	↓	↓	↓	↓	↑	↓	↓	↓	↑	↓	
Acetyl Chloride	↓	↓	↑	↓	↓	↓	↑	↓	↓	↓	↓	↓	↑	↓	
Acetylene	↑	↑	↑	↓	↑	↗		↗	↑	↗	↗	↗	↑	↓	↑
Acetylene Tetrabromide	↓	↑	↑	↓	↓	↗			↑			↓	↑		
Acetylene Tetrachloride	↓	↑	↑	↓	↓	↗			↑			↓	↑		
Acetylsalicylic Acid	↗	↓	↑	→	↗	↓	↗		↓	↓	↓	↓	↑	↓	
Acids, Non-organic													↑		
Acids, Organic													↑		
Aconitic Acid													↑		
Acridine													↑		

Fluid	NBR	EPDM	FKM	TPU	HNBR	CR	FMQ	MQ	IIR	BR	IR	SBR	FFKM	ACM	PTFE
Acrolein	→	↑	↓	↓	→	→	↑	↗	↑	↑	↑	↑	↑	↓	
Acrylic Acid	↗	↓	↑	→	↗	↓	↗		↓	↓	↓	↓	↑	↓	
Acrylonitrile	↓	↓	↓	↓	↓	↓	↓	↓	↓			→	→	↑	↑
Adipic Acid	↑	↑	↑	↓	↑	↑							↑	↓	
Aero Lubriplate	↑	↓	↑	↑	↑	↑	↑	↗	↓	↓	↓	↗	↑	↑	
Aero Shell 17 Grease	↑	↓	↑	↑	↑	↗	↑	↗	↓	↓	↓	↓	↑	↑	
Aero Shell 750	↗	↓	↑	↓	↗	↓	↗	↓	↓	↓	↓	↓	↑	↗	
Aero Shell 7A Grease	↗	↓	↑	↑	↗	↗	↑	↗	↓	↓	↓	↓	↑	↑	
Aero Shell IAC	↑	↓	↑	↑	↑	↗	↑	↗	↓	↓	↓	↓	↑	↑	
Aerosafe 2300	↓	↑	↓	↓	↓	↓	→	→	↗	↓	↓	↓	↑	↓	
Aerosafe 2300W	↓	↑	↓	↓	↓	↓	→	→	↗	↓	↓	↓	↑	↓	
Aerozene 50 (50% Hydrazine 50% UDMH)	↓	↑	↓	↓	↓	↓	↓	↓	↑	↓	↓	↓	↗		
Air, 0-90 °C	↗	↑	↑	↗	↗	↑	↑	↑	↑	↗	↗	↗	↑	↑	↑
Air, 90-150 °C	→	↗	↑	→	→	↗	↑	↑	↗	↓	↓	↓	↑	↗	↑
Air, 150-200 °C	↓	↓	↑	↓	↓	↓	↗	↑	↓	↓	↓	↓	↑	↓	↑
Air, 200-260 °C	↓	↓	→	↓	↓	↓	↓	↗	↓	↓	↓	↓	↗	↓	↑
Aliphatic Dicarboxylic Acid	↗	↓	↑	→	↗	↓	↗		↓	↓	↓	↓	↑	↓	
Alkanes (Paraffin Hydrocarbons)	↑	↓	↑	↑	↑	↗	↑	↗	↓	↓	↓	↓	↑	↑	
Alkanesulfonic Acid	↑	↓	↑	↑	↑	↗	↑	↗	↓	↓	↓	↓	↑	↑	
Alkazene	↓	↓	↗	↓	↓	↓	↗	↓	↓	↓	↓	↓	↑	↓	

# Materials

Fluid	NBR	EPDM	FKM	TPU	HNBR	CR	FMQ	MQ	IIR	BR	IR	SBR	FFKM	ACM	PTFE
Alkenes (Olefin Hydrocarbons)	↗	↘	↗	↗	↗	↘	↗		↘	↘	↘	↘	↗	↘	
Alkyl Acetone	→	↗	→	↘	→	↗	↗	↗	↗	↗	↗	↗	↗	↘	
Alkyl Alcohol	↗	↘	↗	↗	↗	↗	↗	↗	↘	↘	↘	↘	↗	↗	
Alkyl Amine	↗	↘	↗	↗	↗	↗	↗	↗	↘	↘	↘	↘	↗	↗	
Alkyl Aryl Sulfonates	↗	↘	↗	↗	↗	↗	↗	↗	↘	↘	↘	↘	↗	↗	
Alkyl Aryl Sulfonics	↗	↘	↗	↗	↗	↗	↗	↗	↘	↘	↘	↘	↗	↗	
Alkyl Benzene	→	↘	↗	→	↘	↗			↘	↘	↘	↘	↗	↘	
Alkyl Chloride	↗	↘	↗	→	↗	↗			↘	↘	↘	↘	↗	↘	
Alkyl Sulfide	↗	↘	↗	→	↗	↗			↘	↘	↘	↘	↗	↘	
Alkyl naphthalene Sulfonic Acid	↗	↘	↗	↗	↗	↗	↗	↗	↘	↘	↘	↘	↗	↗	
Allyl Chloride	↗	↘	↗		↗	↗							↗		
Allylidene Diacetate	→	↗	→	↘	→	↗	↗	↗	↗	↗	↗	↗	↗	↘	
Alpha Picoline	→	↗	→	↘	→	↗	↗	↗	↗	↗	↗	↗	↗	↘	
Aluminum Acetate	↗	↗	↘	↘	↗	↗	↘	↘	↗	↘	↗	↗	↗	↘	
Aluminum Bromide	↗	↗	↗	→	↗	↗	↗	↗	↗	↗	↗	↗	↗	↗	
Aluminum Chlorate	→	↗	→	↘	→	↗	↗	↗	↗	↗	↗	↗	↗	↘	
Aluminum Chloride	↗	↗	↗	→	↗	↗	↗	↗	↗	↗	↗	↗	↗	↗	
Aluminum Ethylate													↗		
Aluminum Fluoride	↗	↗	↗	→	↗	↗	↗	↗	↗	↗	↗	↗	↗		
Aluminum Fluorosilicate													↗		
Aluminum Formate	→	↗	→	↘	→	↗	↗	↗	↗	↗	↗	↗	↗	↘	
Aluminum Hydroxide	↗	↗	↗				↗						↗		

Fluid	NBR	EPDM	FKM	TPU	HNBR	CR	FMQ	MQ	IIR	BR	IR	SBR	FFKM	ACM	PTFE
Aluminum Linoleate	↗	↘	↗	↗	↗	↗	↗	↗	↘	↘	↘	↘	↗	↗	
Aluminum Nitrate	↗	↗	↗	→	↗	↗		↗	↗	↗	↗	↗	↗	↘	
Aluminum Oxalate	→	↗	→	↘	→	↗	↗	↗	↗	↗	↗	↗	↗	↘	
Aluminum Phosphate	↗	↗	↗	↘	↗	↗		↗					↗	↗	
Aluminum Potassium Sulfate	→	↗	→	↘	→	↗	↗	↗	↗	↗	↗	↗	↗	↘	
Aluminum Salts	↗	↗	↗	→	↗	↗	↗	↗	↗	↗	↗	↗	↗	↗	
Aluminum Sodium Sulfate	→	↗	→	↘	→	↗	↗	↗	↗	↗	↗	↗	↗	↘	
Aluminum Sulfate	↗	↗	↗	↘	↗	↗	↗	↗	↗	↗	↗	↗	↗	↘	
Alums -NH3 -Cr -K	↗	↗	↘		↗	↗	↘	↗	↗	↗	↗	↗	↗	↘	
Ambrex 33 (Mobil)	↗	↘	↗	↗	↗	↗	→	↘	↘	↘	↘	↘	↗	↗	
Ambrex 830 (Mobil)	↗	↘	↗	↗	↗	↗	↗	↗	→	↘	↘	↘	↗	↗	
Amines-Mixed	↘	↗	↘	↘	↘	↗	↘	↗	↗	↗	↗	↗	↗	↘	
Aminoanthraquinone													↗		
Aminoazobenzene													↗		
Aminobenzene Sulfonic Acid													↗		
Aminobenzoic Acid													↗		
Aminopyridine													↗		
Aminosalicic Acid													↗		
Ammonia (Anhydrous)	↗	↗	↘	↘	↗	↗	↘	↗	↗	↘	↘	↘	↗	↘	↗
Ammonia and Lithium Metal in Solution	↗	↗	↘	↘	↗		↘	↘	↗	↘	↘	↘	↘	↘	
Ammonia, Gas, Cold	↗	↗	↘	↘	↗	↗	↘	↗	↗	↗	↗	↗	↗	↘	
Ammonia, Gas, Hot	↘	↗	↘	↘	↘	↗	↘		↗	↘	↘	↘	↗	↘	

Fluid	NBR	EPDM	FKM	TPU	HNBR	CR	FMQ	MQ	IIR	BR	IR	SBR	FFKM	ACM	PTFE
Ammonia, Liquid (Anhydrous)	↗	↗	↘	↘	↗	↗	↘	↗	↗	↘	↘	↘	↗	↘	↗
Ammonium Acetate	→	↗	→	↘	→	↗	↗	↗	↗	↗	↗	↗	↗	↘	
Ammonium Arsenate	→	↗	→	↘	→	↗	↗	↗	↗	↗	↗	↗	↗	↘	
Ammonium Benzoate	→	↗	→	↘	→	↗	↗	↗	↗	↗	↗	↗	↗	↘	
Ammonium Bicarbonate	→	↗	→	↘	→	↗	↗	↗	↗	↗	↗	↗	↗	↘	
Ammonium Bisulfite	→	↗	→	↘	→	↗	↗	↗	↗	↗	↗	↗	↗	↘	
Ammonium Bromide	↗	↗	↗	↗	↗			↗				↗	↗		
Ammonium Carbamate	→	↗	→	↘	→	↗	↗	↗	↗	↗	↗	↗	↗	↘	
Ammonium Carbonate	→	↗	→	↘	→	↗		↗				↗	↗	↘	↗
Ammonium Chloride, 2N	↗	↗	↗	↗	↗			↗				↗	↗		
Ammonium Citrate	→	↗	→	↘	→	↗	↗	↗	↗	↗	↗	↗	↗	↘	
Ammonium Dichromate	→	↗	→	↘	→	↗	↗	↗	↗	↗	↗	↗	↗	↘	
Ammonium Diphosphate	→	↗	→	↘	→	↗	↗	↗	↗	↗	↗	↗	↗	↘	
Ammonium Fluoride	↗	↗	↗	↗	↗	↗		↗				↗	↗	↘	
Ammonium Fluorosilicate													↗		
Ammonium Formate	→	↗	→	↘	→	↗	↗	↗	↗	↗	↗	↗	↗	↘	
Ammonium Hydroxide, 3 Molar	↗	↗	→	↘	↗	↗	↗	↗	↗	↗	↗	↗	↗	↘	
Ammonium Hydroxide, Concentrated	↘	↗	↘	↘	↘	↗	↗	↗	↗	↗	↗	↗	↗	↘	
Ammonium Iodide	↗	↗	↗	↗	↗			↗				↗	↗		
Ammonium Lactate	→	↗	→	↘	→	↗	↗	↗	↗	↗	↗	↗	↗	↘	
Ammonium Metaphosphate	→	↗	→	↘	→	↗	↗	↗	↗	↗	↗	↗	↗	↘	
Ammonium Molybdenate	→	↗	→	↘	→	↗	↗	↗	↗	↗	↗	↗	↗	↘	

# Materials

Fluid	NBR	EPDM	FKM	TPU	HNBR	CR	FMQ	MQ	IR	BR	IR	SBR	FFKM	ACM	PTFE
Ammonium Nitrate, 2N	↑	↑			↑	↑			↑			↑			↑
Ammonium Nitrite	↑	↑			↑	↑			↑	↑	↑	↑	↑		
Ammonium Oxalate	→	↑	→	↓	→	↑	↑	↑	↑	↑	↑	↑	↑	↓	
Ammonium Perchlorate	→	↑	→	↓	→	↑	↑	↑	↑	↑	↑	↑	↑	↓	
Ammonium Perchloride													↑		
Ammonium Persulfate 10%	↓	↑		↓	↓	↑			↑		↑	↓		↓	
Ammonium Persulfate Solution	↓	↑		↓	↓				↑		↑	↓	↑	↓	
Ammonium Phosphate	↑	↑	↓		↑	↑			↑	↑	↑	↑	↑		
Ammonium Phosphate, Dibasic	↑	↑			↑	↑			↑	↑	↑	↑	↑		
Ammonium Phosphate, Mono-Basic	↑	↑			↑	↑			↑	↑	↑	↑	↑		
Ammonium Phosphate, Tribasic	↑	↑			↑	↑			↑	↑	↑	↑	↑		
Ammonium Phosphite	→	↑	→	↓	→	↑	↑	↑	↑	↑	↑	↑	↑	↓	
Ammonium Picrate	→	↑	→	↓	→	↑	↑	↑	↑	↑	↑	↑	↑	↓	
Ammonium Polysulfide	→	↑	→	↓	→	↑	↑	↑	↑	↑	↑	↑	↑	↓	
Ammonium Salicylate	→	↑	→	↓	→	↑	↑	↑	↑	↑	↑	↑	↑	↓	
Ammonium Salts	↑	↑	→		↑	↑	→	↑	↑		↑	↑	↑	→	
Ammonium Sulfamate	→	↑	→	↓	→	↑	↑	↑	↑	↑	↑	↑	↑	↓	
Ammonium Sulfate	↑	↑	↓		↑	↑			↑	↑	↑	↑	↑	↓	↑
Ammonium Sulfate Nitrate	↑	↑	↓		↑	↑			↑	↑	↑	↑	↑	↓	
Ammonium Sulfide	↑	↑	↓	↓	↑	↑			↑	↑	↑	↑	↑	↓	
Ammonium Sulfite	→	↑	→	↓	→	↑	↑	↑	↑	↑	↑	↑	↑	↓	
Ammonium Thiocyanate	→	↑	→	↓	→	↑	↑	↑	↑	↑	↑	↑	↑	↓	

Fluid	NBR	EPDM	FKM	TPU	HNBR	CR	FMQ	MQ	IR	BR	IR	SBR	FFKM	ACM	PTFE
Ammonium Thioglycolate	→	↑	→	↓	→	↑	↑	↑	↑	↑	↑	↑	↑	↓	
Ammonium Thiosulfate	→	↑	→	↓	→	↑	↑	↑	↑	↑	↑	↑	↑	↓	
Ammonium Tungstate	→	↑	→	↓	→	↑	↑	↑	↑	↑	↑	↑	↑	↓	
Ammonium Valerate	→	↑	→	↓	→	↑	↑	↑	↑	↑	↑	↑	↑	↓	
Amyl Acetate	↓	↑	↓	↓	↓	↓	↓	↓	→	↓	↓	↓	↑	↓	↑
Amyl Alcohol	↑	↑	↑	↓	↑	↑	↑	↓	↑	↑	↑	↑	↑	↓	↑
Amyl Borate	↑	↓	↑		↑	↑			↓	↓	↓	↓	↑		
Amyl Butyrate	↑	↓	↑	↑	↑	↑	↑	↑	↓	↓	↓	↓	↑	↑	
Amyl Chloride	↓	↓	↑		↓	↓	↑	↓	↓	↓	↓	↓	↑	↓	
Amyl Chloronaphthalene	↓	↓	↑		↓	↓	↑	↓	↓	↓	↓	↓	↑	↓	
Amyl Cinnamic Aldehyde	↑	↓	↑	→	↑	↓	↑		↓	↓	↓	↓	↑	↓	
Amyl Laurate	↑	↓	↑	→	↑	↓	↑		↓	↓	↓	↓	↑	↓	
Amyl Mercaptan	↑	↓	↑	→	↑	↓	↑		↓	↓	↓	↓	↑	↓	
Amyl Naphthalene	↓	↓	↑	↓	↓	↓	↑	↓	↓	↓	↓	↓	↑	↓	
Amyl Nitrate	→	↑	→	↓	→	↑	↑	↑	↑	↑	↑	↑	↑	↓	
Amyl Nitrite	→	↑	→	↓	→	↑	↑	↑	↑	↑	↑	↑	↑	↓	
Amyl Phenol													↑		
Amyl Propionate	↑	↓	↑	↑	↑	↑	↑	↑	↓	↓	↓	↓	↑	↑	
AN-O-3 Grade M	↑	↓	↑	↑	↑	↑	↑	↑	↓	↓	↓	↓	↑	↑	
AN-O-366	↑	↓	↑	↑	↑	↑	↑	↑	↓	↓	↓	↓	↑	↑	
AN-O-6	↑	↓	↑	↑	↑	↑	↑	↑	↓	↓	↓	↓	↑	↑	
AN-VV-O-366b Hydr. Fluid	↑	↓	↑	↑	↑	↑	↑	↑	↓	↓	↓	↓	↑	↑	

Fluid	NBR	EPDM	FKM	TPU	HNBR	CR	FMQ	MQ	IR	BR	IR	SBR	FFKM	ACM	PTFE
Anderol, L-826 (di-ester)	↑	↓	↑	↓	↑	↓	↑	↓	↓	↓	↓	↓	↑	↑	
Anderol, L-829 (di-ester)	↑	↓	↑	↓	↑	↓	↑	↓	↓	↓	↓	↓	↑	↑	
Anderol, L-774 (di-ester)	↑	↓	↑	↓	↑	↓	↑	↓	↓	↓	↓	↓	↑	↑	
ANG-25 (Di-ester Base) (TG749)	↑	↓	↑	↓	↑	↓	↑	↓	↓	↓	↓	↓	↑	↑	
ANG-25 (Glyceral Ester)	↑	↑	↑	↓	↑	↑	↑	↑	↑	↑	↑	↑	↑	↓	
Aniline	↓	↑	→	↓	↓	↓	→	↓	↑	↓	↓	↓	↑	↓	↑
Aniline Dyes	↓	↑	↑	↓	↓	↑	↑	→	↑	↑	↑	↑	↑	↓	
Aniline Hydrochloride	↑	↑	↑	↓	↑	↓	↑	→	↑	↓	↑	→	↑	↓	
Aniline Oil	↓	↑	→	↓	↓	↓	→	↓	↑	↓	↓	↓	↑	↓	
Aniline Sulfate	→	↑	→	↓	→	↑	↑	↑	↑	↑	↑	↑	↑	↓	
Aniline Sulfite	→	↑	→	↓	→	↑	↑	↑	↑	↑	↑	↑	↑	↓	
Animal Fats	↑	↑	↑	↑	↑	↑							↑	↑	
Animal Oil (Lard Oil)	↑	↑	↑	↑	↑	↑	↑	↑	↑	↓	↓	↓	↑	↑	
Anisole	↓	↓	↓	↓	↓	↓							↑	↓	↑
Anisoyl Chloride													↑		
Ansul Ether 161 or 181	→	→	↓	↑	→	↓	→	↓	→	↓	↓	↓	↑	↓	
Anthracene	↑	↓	↑	→	↑	↓	↑		↓	↓	↓	↓	↑	↓	
Anthranilic Acid													↑		
Anthraquinone													↑		
Anti-freeze Solutions	→	↑	→	↓	→	↑	↑	↑	↑	↑	↑	↑	↑	↓	↑
Antimony Chloride	↑	↑	↑	→	↑	↑	↑	↓	↓	↓	↓	↓	↑	↑	
Antimony Pentachloride	↑	↓	↑	↑	↑	↑	↑	↓	↓	↓	↓	↓	↑	↑	

# Materials

Fluid	NBR	EPDM	FKM	TPU	HNBR	CR	FMQ	MQ	IIR	BR	IR	SBR	FFKM	ACM	PTFE
Antimony Pentafluoride													↗		
Antimony Sulfate													↗		
Antimony Tribromide	↗	↘	↗	↗	↗	↗	↘	↘	↘	↘	↘	↘	↗	↗	
Antimony Trichloride	↗	↘	↗	↗	↗	↗	↘	↘	↘	↘	↘	↘	↗	↗	
Antimony Trifluoride	↗	↘	↗	↗	↗	↗	↘	↘	↘	↘	↘	↘	↗	↗	
Antimony Trioxide	↗	↘	↗	↗	↗	↗	↘	↘	↘	↘	↘	↘	↗	↗	
Aqua Regia	↘	→	↗		→	↘							↗		↗
Arachidic Acid													↗		
Argon	↗	↗	↗	↗	↗	↗	↗	↗	↗	↗	↗	↗	↗	↗	
Aroclor, 1248	→	↗	↗	↘	→	↘	↗	↗	↘	↘	↘	↘	↗	↘	
Aroclor, 1254	↘	↗	↗	↘	↘	↘	↗	→	↘	↘	↘	↘	↗	↘	
Aroclor, 1260	↗		↘	↗	↗	↗	↗	↗	↗	↗	↗	↗	↗	↘	
Aromatic Fuel -50%	↗	↘	↗	→	↗	↘	↗	↘	↘	↘	↘	↘	↗	→	
Arsenic Acid	↗	↗	↗	→	↗	↗	↗	↗	↗	↗	↗	↗	↗	→	↗
Arsenic Oxide													↗		
Arsenic Trichloride	↗	↘	↘		↗	↗							↗		
Arsenic Trioxide	↗	↘	↘		↗	↗							↗		
Arsenic Trisulfide	↗	↘	↘		↗	↗							↗		
Arsenites													↗		
Arsine													↗		
Aryl Orthosilicate													↗		
Ascorbic Acid	→	↗	↘	→	↗	↗	↗	↗	↗	↗	↗	↗	↗	↘	

Fluid	NBR	EPDM	FKM	TPU	HNBR	CR	FMQ	MQ	IIR	BR	IR	SBR	FFKM	ACM	PTFE
Askarel Transformer Oil	↗	↘	↗	↗	↗	↘	↗	↘	↘	↘	↘	↘	↗	↘	
Aspartic Acid	→	↗	→	↘	→	↗	↗	↗	↗	↗	↗	↗	↗	↘	
Asphalt	↗	↘	↗	↗	↗	↗	↗	↘	↘	↘	↘	↘	↗	↗	↗
ASTM Oil, No. 1	↗	↘	↗	↗	↗	↗	↗	↘	↘	↘	↘	↘	↗	↗	↗
ASTM Oil, No. 2	↗	↘	↗	↗	↗	↗	↗	↘	↘	↘	↘	↘	↗	↗	↗
ASTM Oil, No. 3	↗	↘	↗	↗	↗	↘	↗	→	↘	↘	↘	↘	↗	↗	↗
ASTM Oil, No. 4	↗	↘	↗	↘	↗	↘	↗	↘	↘	↘	↘	↘	↗	↗	
ASTM Oil, No. 5	↗	↘	↗		↗	↗							↗		
ASTM Reference Fuel A	↗	↘	↗	↗	↗	↗	↘	↘	↘	↘	↘	↘	↗	↗	↗
ASTM Reference Fuel B	↗	↘	↗	→	↗	↘	↘	↘	↘	↘	↘	↘	↗	↘	↗
ASTM Reference Fuel C	↗	↘	↗	↗	↗	↗	↘	↘	↘	↘	↘	↘	↗	↘	↗
ASTM Reference Fuel D	↗	↘	↗		↗	↘							↗		
ATL-857	↗	↘	↗	↘	↗	↘	↘	↘	↘	↘	↘	↘	↗	↗	
Atlantic Dominion F	↗	↘	↗	↗	↗	↗	↘	↘	↘	↘	↘	↘	↗	↗	
Atlantic Utro Gear-e	↗	↘	↗		↗	↗							↗		
Atlantic Utro Gear-EP Lube	↗	↘	↗	↗	↗	↗	↘	↘	↘	↘	↘	↘	↗	↗	
Aure 903R (Mobil)	↗	↘	↗	↗	↗	↗	↘	↘	↘	↘	↘	↘	↗	↗	
AUREX 256													↗		
Automatic Transmission Fluid (ATF)	↗	↘	↗	↗	↗	↗		↘	↘	↘	↘	↘	↗	↘	↗
Automotive Brake Fluid	→	↗	↘	↘	→	↗	↘	→	↗				↗	↗	↗
AXAREL 9100													↗		
Azobenzene													↗		

Fluid	NBR	EPDM	FKM	TPU	HNBR	CR	FMQ	MQ	IIR	BR	IR	SBR	FFKM	ACM	PTFE
Bardol B	↘	↘	↘	↘	↘	↘	↗	↘	↘	↘	↘	↘	↘	↘	
Barium Carbonate	→	↗	→	↘	→	↗	↗	↗	↗	↗	↗	↗	↗	↘	
Barium Chlorate	→	↗	→	↘	→	↗	↗	↗	↗	↗	↗	↗	↗	↘	
Barium Chloride	↗	↗	↗	↗	↗	↗	↗	↗	↗	↗	↗	↗	↗	↗	
Barium Cyanide	↗	↗	↗	↗	↗	↗	↗	↗	↗	↗	↗	↗	↗	↗	
Barium Hydroxide	↗	↗	↘	↗	↗	↗	↗	↗	↗	↗	↗	↗	↗	↘	↗
Barium Iodide	↗	↗	↗	↗	↗	↗	↗	↗	↗	↗	↗	↗	↗	↗	
Barium Nitrate	→	↗	→	↘	→	↗	↗	↗	↗	↗	↗	↗	↗	↘	
Barium Oxide	↗	↗	↘	↗	↗	↗	↗	↗	↗	↗	↗	↗	↗	↘	
Barium Peroxide	→	↗	→	↘	→	↗	↗	↗	↗	↗	↗	↗	↗	↘	
Barium Polysulfide	→	↗	→	↘	→	↗	↗	↗	↗	↗	↗	↗	↗	↘	
Barium Salts	↗	↗	↗	↗	↗	↗	↗	↗	↗	↗	↗	↗	↗	↗	↗
Barium Sulfate	↗	↗	↗	↗	↗								↗	↗	
Barium Sulfide	↗	↗	↗	↗	↗	↗	↗	↗	↗	↗	↗	↗	↗	↘	
Bayol 35	↗	↘	↗	↗	↗	↗	↘	↘	↘	↘	↘	↘	↗	↗	
Bayol D	↗	↘	↘	↗	↗	↗	↘	↘	↘	↘	↘	↘	↗	↗	
Beer	↗	↗	↗	→	↗	↗	↗	↗	↗	↗	↗	↗	↗	↘	↗
Beet Sugar Liquids	↗	↗	↗		↗	↗							↗		
Beet Sugar Liquors	↗	↗	↘	↗	↗	↗	↗	↗	↗	↗	↗	↗	↗	↘	
Benzaldehyde	↘	↗	↘	↘	↘	↘	↘	↗	↗	↘	↘	↘	↗	↘	↗
Benzaldehyde Disulfonic Acid														↗	
Benzamide	↗	↘	↗	→	↗	↘	↗		↘	↘	↘	↘	↗	↘	

# Materials

Fluid	NBR	EPDM	FKM	TPU	HNBR	CR	FMQ	MQ	IR	BR	IR	SBR	FFKM	ACM	PTFE
Benzanthrone	↗	↘	↗	↗	↗	↘	↗		↘	↘	↘	↘	↗	↘	
Benzene	↘	↘	↗	↘	↘	↗	↘	↘	↘	↘	↘	↘	↗	↘	↗
Benzene Hexachloride													↗		
Benzenesulfonic Acid 10%	↘	↘	↗	↘	↗	↗	↘	↘	↘	↘	↘	↘	↗	↘	
Benzidine	↗	↘	↗	↗	↗	↘			↘	↘	↘	↘	↗	↘	
Benzidine 3 Sulfonic Acid	↗	↘	↗	↗	↗	↘			↘	↘	↘	↘	↗	↘	
Benzil	↗	↘	↗	↗	↗	↘			↘	↘	↘	↘	↗	↘	
Benzilic Acid	↗	↘	↗	↗	↗	↘			↘	↘	↘	↘	↗	↘	
Benzine (Ligroin)	↗	↘	↗	↗	↗	↘	↘	↘	↘	↘	↘	↘	↗	↗	
Benzocatechol	↗	↘	↗	↗	↗	↘			↘	↘	↘	↘	↗	↘	
Benzochloride	↘	↗	↗		↘	↘	↗		↗	↘	↘	↘	↗	↘	
Benzoic Acid	↘	↘	↗	↘	↘	↗	↘	↘	↘	↘	↘	↘	↗	↘	↗
Benzoin	↗	↘	↗	↗	↗	↘			↘	↘	↘	↘	↗	↘	
Benzonitrile	↗	↗	↗	↘	↗	↗	↗	↗	↗	↗	↗	↗	↗	↘	
Benzophenone		↗	↗	↘			↗		↗	↘	↘	↘	↗	↘	
Benzoquinone		↗	↗	↘				↗	↘	↘	↘	↘	↗	↘	
Benzotrichloride	↘	↗	↗		↘	↘							↗		
Benzotrifluoride	↘	↗	↗		↘	↘							↗		
Benzoyl Chloride			↗	↗		↘	↗		↘	↘	↘	↘	↗	↘	
Benzoyl Peroxide													↗		
Benzoylsulfonic Acid	↗	↘	↗	↗	↗	↘			↘	↘	↘	↘	↗	↘	
Benzyl Acetate	↗	↗	↗	↘	↗	↗	↗	↗	↗	↗	↗	↗	↗	↘	

Fluid	NBR	EPDM	FKM	TPU	HNBR	CR	FMQ	MQ	IR	BR	IR	SBR	FFKM	ACM	PTFE
Benzyl Alcohol	↘	↗	↗	↘	↘	↗	↗	↗	↗	↘	↘	↘	↗	↘	↗
Benzyl Amine													↗		
Benzyl Benzoate	↘	↘	↗	↘	↘	↘	↗	↘	↗	↘	↘	↘	↗	↘	
Benzyl Bromide	↘	↘	↗	↘	↘	↘	↗	↘	↘	↘	↘	↘	↗	↘	
Benzyl Butyl Phthalate	↗	↗	↗	↘	↗	↗	↗	↗	↗	↗	↗	↗	↗	↘	
Benzyl Chloride	↘	↘	↗	↘	↘	↘	↗	↘	↘	↘	↘	↘	↗	↘	
Benzyl Phenol	↗	↘	↗	↗	↗	↘	↗		↘	↘	↘	↘	↗	↘	
Benzyl Salicylate	↗	↘	↗	↗	↗	↘	↗		↘	↘	↘	↘	↗	↘	
Beryllium Chloride	↗	↗	↗	↗	↗	↗	↗	↗	↗	↗	↗	↗	↗	↗	↗
Beryllium Fluoride	↗	↗	↗	↗	↗	↗	↗	↗	↗	↗	↗	↗	↗	↗	↗
Beryllium Oxide	↗	↗	↗	↗	↗	↗	↗	↗	↗	↗	↗	↗	↗	↗	↗
Beryllium Sulfate	↗	↗	↗	↘	↗	↗	↗	↗	↗	↗	↗	↗	↗	↘	
Bismuth Carbonate	↗	↗	↗	↘	↗	↗	↗	↗	↗	↗	↗	↗	↗	↘	
Bismuth Nitrate	↗	↗	↗	↘	↗	↗	↗	↗	↗	↗	↗	↗	↗	↘	
Bismuth Oxychloride	↗	↗	↗	↘	↗	↗	↗	↗	↗	↗	↗	↗	↗	↘	
Bittern													↗		
Black Liquor	↗	↗	↗	↘	↗	↗							↗	↘	↗
Black Point 77	↗	↗	↗	↗	↗	↗	↗	↗	↗	↗	↗	↗	↗	↗	↗
Blast Furnace Gas	↘	↘	↗	↘	↘	↘	↗	↗	↘	↘	↘	↘	↗	↗	↗
Bleach Liquor	↗	↗	↗	↘	↗	↗	↗	↗	↗	↗	↗	↗	↗	↘	
Bleach Solutions	↘	↗	↗	↘	↘	↘							↗	↘	
Borax	↗	↗	↗	↗	↗	↗	↗	↗	↗	↗	↗	↗	↗	↗	↗

Fluid	NBR	EPDM	FKM	TPU	HNBR	CR	FMQ	MQ	IR	BR	IR	SBR	FFKM	ACM	PTFE
Borax Solutions	↗	↗	↗	↘	↗	↘							↗	↘	
Bordeaux Mixture	↗	↗	↗	↘	↗	↗	↗	↗	↗	↗	↗	↗	↗	↘	
Boric Acid	↗	↗	↗	↗	↗	↗	↗	↗	↗	↗	↗	↗	↗	↘	
Boric Oxide	↗	↗	↗	↘	↗	↗	↗	↗	↗	↗	↗	↗	↗	↘	
Borneol	↗	↘	↗	↗	↗	↘			↘	↘	↘	↘	↗	↘	
Bornyl Acetate	↗	↘	↗	↗	↗	↘			↘	↘	↘	↘	↗	↘	
Bornyl Chloride	↗	↘	↗	↗	↗	↘			↘	↘	↘	↘	↗	↘	
Bornyl Formate	↗	↘	↗	↗	↗	↘			↘	↘	↘	↘	↗	↘	
Boron Fluids (HEF)	↗	↘	↗	↘	↗	↘	↘	↘	↘	↘	↘	↘	↗	↘	
Boron Hydride													↗		
Boron Phosphate													↗		
Boron Tribromide													↗		
Boron Trichloride													↗		
Boron Trifluoride													↗		
Boron Trioxide													↗		
Brake Fluid DOT3 (Glycol Type)	↗	↗	↘	↘	↗	↘	↗	↗	↗			↗	↗	↗	↗
Bray GG-130	↗	↘	↗	↘	↗	↘	↘	↘	↘	↘	↘	↘	↗	↗	
Brayco 719-R (VV-H-910)	↗	↗	↘	↘	↗	↗	↗	↗	↗	↗	↗	↗	↗	↘	
Brayco 885 (MIL-L-6085A)	↗	↘	↗	↗	↗	↘	↘	↘	↘	↘	↘	↘	↗	↗	
Brayco 910	↗	↗	↘	↗	↗	↘	↘	↘	↘	↘	↘	↘	↗	↗	↗
Bret 710	↗	↗	↘	↗	↗	↘	↘	↘	↘	↘	↘	↘	↗	↗	↗
Brine	↗	↗	↗		↗								↗		

# Materials

Fluid	NBR	EPDM	FKM	TPU	HNBR	CR	FMQ	MQ	IIR	BR	IR	SBR	FFKM	ACM	PTFE
Brine (Seawater)	↑	→	↑		↑	↓							↑		
Brom - 113	→	↓			→	↓		↓	↓			↓			
Brom - 114	↑	↓	↑		↑	↑		↓	↓	↓	↓	↓	↑		
Bromic Acid	→	↑	→	↓	→	↑	↑	↑	↑	↑	↑	↑	↑	↓	
Bromine	↓	↓	↑	↓	↓	↓	↑	↓	↓	↓	↓	↓	↑	↓	
Bromine Pentafluoride	↓	↓	↓	↓	↓	↓	↓	↓	↓	↓	↓	↓	↑	↓	
Bromine Trifluoride	↓	↓	↓	↓	↓	↓	↓	↓	↓	↓	↓	↓	↑	↓	
Bromine Water	↓	↑	↑	↓	↓	↓	↑	↓	↓	↓	↓	↓	↑	↓	
Bromobenzene	↓	↓	↑	↓	↓	↓	↑	↓	↓	↓	↓	↓	↑	↓	
Bromobenzene Cyanide	→	↑	→	↓	→	↑	↑	↑	↑	↑	↑	↑	↑	↓	
Bromochlorotrifluoroethane (Halothane)	↓	↓	↑	↓	↓	↓	↑	↓	↓	↓	↓	↓	↑	↓	
Bromoform	↑	↓	↑	→	↑	↓	↑		↓	↓	↓	↓	↑	↓	
Bromomethane (Methyl Bromide)	↑	↓	↑		↑	↓	↑		↓	↓	↓	↓	↑	→	
Bromotrifluoroethylene (BFE)													↑		
Bromotrifluoromethane (F-13B1)													↑		
Brucine Sulfate	→	↑	→	↓	→	↑	↑	↑	↑	↑	↑	↑	↑	↓	
Buffered Oxide Etchants													↑		
Bunker Oil	↑	↓	↑	↑	↑	↓	↑	↑	↓	↓	↓	↓	↑	↑	↑
Bunker's "C" (Fuel Oil)	↑	↑											↑		
Butadiene (Monomer)	↓	↓	↑	↓	↓	↓	↑	↓	↓	↓	↓	↓	↑	↓	↑
Butane	↑	↓	↑	↑	↑	↑	→	↓	↓	↓	↓	→	↑	↑	↑
Butane, 2, 2-Dimethyl	↑	↓	↑	↑	↑	↑	→	↓	↓	↓	↓	→	↑	↑	

Fluid	NBR	EPDM	FKM	TPU	HNBR	CR	FMQ	MQ	IIR	BR	IR	SBR	FFKM	ACM	PTFE
Butane, 2, 3-Dimethyl	↑	↓	↑	↓	↑	↑	→	↓	↓	↓	↓	→	↑	↑	
Butanediol	↑	↑	→	↓	↑	↑	↑	↑	↑	↑	↑	↑	↑	↓	↑
Butanol (Butyl Alcohol)	↑	↑	↑	↓	↑	↑	↑	↑	↑	↑	↑	↑	↑	↓	
Butene 2-Ethyl (1-Butene 2-Ethyl)	↑	↓	↑	↓	↑	↓	→	↓	↓	↓	↓	↓	↑	↑	
Butter-Animal Fat	↑	↑	↑	↑	↑	↑	↑	↑	↑	↓	↓	↓	↑	↑	↑
Butyl Acetate or n-Butyl Acetate	↓	↑	↓	↓	↓	↓	↓	↓	↑	↓	↓	↓	↑	↓	↑
Butyl Acetyl Ricinoleate	↑	↑	↑	↓	↑	↑			↑	↓	↓	↓	↑		
Butyl Acrylate	↓	↓	↓		↓	↓	↓	↑	↓	↓	↓	↓	↑	↓	
Butyl Alcohol	↑	↑	↑	↑	↑	↑	↑	↑	↑	↑	↑	↑	↑	↓	↑
Butyl Alcohol (Secondary)	↑	↑	↑	↓	↑	↑	↑	↑	↑	↑	↑	↑	↑	↓	
Butyl Alcohol (Tertiary)	↑	↑	↑	↓	↑	↑	↑	↑	↑	↑	↑	↑	↑	↓	
Butyl Amine or N-Butyl Amine	↑	→	↓	↓	↑	↓	↓	↓	↓	↓	↓	↓	↑	↓	
Butyl Benzoate	→	↑	→	↓	→	↑	↑	↑	↑	↑	↑	↑	↑	↓	
Butyl Benzoate or n-Butyl Benzoate	↓	↑	↑		↓	↓	↑		↑	↓	↓	↑	↑	↓	
Butyl Benzolate													↑		
Butyl Butyrate or n-Butyl Butyrate	↓	↑	↑		↓	↓	↑		↑	↓	↓	↓	↑	↓	
Butyl Carbitol	↓	↑	→		↓	→	↓	↓	↑	↓	↓	↓	↑	↓	
Butyl Cellosolve	→	↑	↓	↓	→	→	↓		↑	↓	↓	↓	↑	↓	
Butyl Cellosolve Acetate	→	↑	→	↓	→	↑	↑	↑	↑	↑	↑	↑	↑	↓	
Butyl Cellosolve Adipate	↓	↑	↑	↓	↓	↓	↑	↑	↑	↑	↑	↑	↑	↓	
Butyl Chloride	↑	↓	↑	↑	↑	↑	↑	↑	↑	↓	↓	↓	↑	↑	
Butyl Ether or n-Butyl Ethe	↓	→	→	→	→	↓	→	↓	→	↓	↓	↓	↑	↓	

Fluid	NBR	EPDM	FKM	TPU	HNBR	CR	FMQ	MQ	IIR	BR	IR	SBR	FFKM	ACM	PTFE
Butyl Glycolate	→	↑	↑	↓	→	↑	↑	↑	↑	↑	↑	↑	↑	↓	
Butyl Lactate	→	↑	→	↓	→	↑	↑	↑	↑	↑	↑	↑	↑	↓	
Butyl Laurate	→	↑	→	↓	→	↑	↑	↑	↑	↑	↑	↑	↑	↓	
Butyl Mercaptan (Tertiary)	↑	↓	↓	↓	↓		↓	↓	↓	↓	↓	↓	↑	↓	
Butyl Methacrylate	→	↑	→	↓	→	↑	↑	↑	↑	↑	↑	↑	↑	↓	
Butyl Oleate	↓	↑	↑		↓	↓	↑		↑	↓		↓	↑		
Butyl Oxalate	→	↑	→	↓	→	↑	↑	↑	↑	↑	↑	↑	↑	↓	
Butyl Stearate	↑	↓	↑	↑	↑	↑	↑		↓	↓	↓	↓	↑		
Butylbenzoic Acid	↑	↓	↑	→	↑	↓	↑		↓	↓	↓	↓	↑	↓	
Butylene	↑	↓	↑	↓	↑	→	↑	↓	↓	↓	↓	↓	↑	↓	↑
Butyraldehyde	↓	↑	↓	↓	↓	↓	↓	↓	↑	↓	↓	↓	↑	↓	↑
Butyric Acid	↑	→	↑	↓	↑	→			↑	↓		↓	↑	↓	↑
Butyric Anhydride	→	↑	→	↓	→	↑	↑	↑	↑	↑	↑	↑	↑	↓	
Butyrolacetone	→	↑	→	↓	→	↑	↑	↑	↑	↑	↑	↑	↑	↓	
Butyryl Chloride	↑	↓	↑	→	↑	↓	↑		↓	↓	↓	↓	↑	↓	
Cadmium Chloride	→	↑	→	↓	→	↑	↑	↑	↑	↑	↑	↑	↑	↓	
Cadmium Cyanide	→	↑	→	↓	→	↑	↑	↑	↑	↑	↑	↑	↑	↓	
Cadmium Nitrate	→	↑	→	↓	→	↑	↑	↑	↑	↑	↑	↑	↑	↓	
Cadmium Oxide	→	↑	→	↓	→	↑	↑	↑	↑	↑	↑	↑	↑	↓	
Cadmium Sulfate	→	↑	→	↓	→	↑	↑	↑	↑	↑	↑	↑	↑	↓	
Cadmium Sulfide	→	↑	→	↓	→	↑	↑	↑	↑	↑	↑	↑	↑	↓	
Calcine Liquors	↑	↑	↑	↓	↑		↑		↑				↑	↓	

# Materials

Fluid	NBR	EPDM	FKM	TPU	HNBR	CR	FMQ	MQ	IIR	BR	IR	SBR	FFKM	ACM	PTFE
Calcium Acetate	↗	↕	↘	↗	↗	↗	↘	↘	↕	↘	↕	↕	↕	↘	
Calcium Arsenate	→	↕	→	↘	→	↕	↗	↗	↗	↗	↗	↗	↗	↘	
Calcium Benzoate	↗	↘	↕	→	↗	↘	↗		↘	↘	↘	↕	↕	↘	
Calcium Bicarbonate	→	↕	→	↘	→	↕	↗	↗	↗	↗	↗	↗	↗	↘	
Calcium Bisulfide	→	↕	→	↘	→	↕	↗	↗	↗	↗	↗	↗	↗	↘	
Calcium Bisulfite	↗	↕	↗	→	↗	↗	→	→	↕	↘	↘	↗	↕	→	↕
Calcium Bromide	↕	↕	↕	↕	↕	↕	↕	↕	↕	↕	↕	↕	↕	↕	
Calcium Carbide													↕		
Calcium Carbonate	↕	↕	↕	↕	↕	↕	↕	↕	↕	↕	↕	↕	↕		
Calcium Chlorate	→	↕	→	↘	→	↕	↗	↗	↗	↗	↗	↗	↗	↘	
Calcium Chloride	↕	↕	↕	↗	↕	↕	↕	↕	↕	↕	↕	↕	↕	↗	↕
Calcium Chromate	→	↕	→	↘	→	↕	↗	↗	↗	↗	↗	↗	↗	↘	
Calcium Cyanamide													↕		
Calcium Cyanide	↕	↕			↕	↕	↕	↕	↕	↕	↕	↕	↕		
Calcium Fluoride	↕	↕	↕	↕	↕	↕	↕	↕	↕	↕	↕	↕	↕	↕	
Calcium Gluconate	→	↕	→	↘	→	↕	↗	↗	↗	↗	↗	↗	↗	↘	
Calcium Hydride	↕	↕	↕	↕	↕	↕	↕	↕	↕	↕	↕	↕	↕	↕	
Calcium Hydrosulfide	→	↕	→	↘	→	↕	↗	↗	↗	↗	↗	↗	↗	↘	
Calcium Hydroxide	↕	↕	↕	↗	↕	↕	↕	↕	↕	↕	↕	↕	↕	↘	↕
Calcium Hypochlorite	↗	↕	↕	↘	↗	↗	↗	↗	↗	↗	↗	↗	↗	↘	
Calcium Hypophosphite	→	↕	→	↘	→	↕	↗	↗	↗	↗	↗	↗	↗	↘	
Calcium Lactate	→	↕	→	↘	→	↕	↗	↗	↗	↗	↗	↗	↗	↘	

Fluid	NBR	EPDM	FKM	TPU	HNBR	CR	FMQ	MQ	IIR	BR	IR	SBR	FFKM	ACM	PTFE
Calcium Naphthenate													↕		
Calcium Nitrate	↕	↕	↕	↗	↕	↕	↕	↕	↕	↕	↕	↕	↕	↗	↕
Calcium Oxalate	→	↕	→	↘	→	↕	↗	↗	↗	↗	↗	↗	↗	↘	
Calcium Oxide	↕	↕	↕	↕	↕	↕	↕	↕	↕	↕	↕	↕	↕	↘	
Calcium Permanganate													↕		
Calcium Peroxide													↕		
Calcium Phenolsulfonate	→	↕	→	↘	→	↕	↗	↗	↗	↗	↗	↗	↗	↘	
Calcium Phosphate	↕	↕	↕	↕	↕	↗	↕	↕	↕	↕	↕	↕	↕	↕	↕
Calcium Phosphate Acid	→	↕	→	↘	→	↕	↗	↗	↗	↗	↗	↗	↗	↘	
Calcium Propionate	→	↕	→	↘	→	↕	↗	↗	↗	↗	↗	↗	↗	↘	
Calcium Pyridine Sulfonate													↕		
Calcium Salts	↕	↕	↕	↕	↕	↕	↕	↕	↕	↕	↕	↕	↕	↕	
Calcium Silicate	↕	↕	↕		↕	↕			↕	↕	↕	↕	↕		
Calcium Stearate	↗	↘	↕	→	↗	↘	↗		↘	↘	↘	↘	↕	↘	
Calcium Sulfamate	↗	↘	↕	→	↗	↘	↗		↘	↘	↘	↘	↕	↘	
Calcium Sulfate	↕	↕	↕	↕	↕		↕	↗	↕	↕	↕	↕	↕	↘	
Calcium Sulfide	↕	↕	↕	↕	↕	↕	↕	↕	↕	↕	↕	↕	↕	↘	
Calcium Sulfite	↕	↕	↕	↕	↕	↕	↕	↕	↕	↕	↕	↕	↕	↘	
Calcium Thiocyanate	→	↕	→	↘	→	↕	↗	↗	↗	↗	↗	↗	↗	↘	
Calcium Thiosulfate	↗	↕	↕	↕	↗	↕	↕	↕	↕	↕	↕	↕	↕	↘	
Calcium Tungstate	→	↕	→	↘	→	↕	↗	↗	↗	↗	↗	↗	↗	↘	
Caliche Liquors	↕	↕	↕	↕	↕	↕	↕	↕	↕	↕	↕	↕	↕	↕	

Fluid	NBR	EPDM	FKM	TPU	HNBR	CR	FMQ	MQ	IIR	BR	IR	SBR	FFKM	ACM	PTFE
Camphene	↗	↘	↕	→	↗	↘	↗		↘	↘	↘	↘	↕	↘	
Camphor	↗	↘	↕	→	↗	↘	↗		↘	↘	↘	↘	↕	↘	↕
Camphoric Acid	↗	↘	↕	→	↗	↘	↗		↘	↘	↘	↘	↕	↘	
Cane Sugar Liquors	↕	↕	↕	↘	↕	↕	↕	↕	↕	↕	↕	↕	↕	↘	
Capric Acid	↕	↘	↕	↕	↕	↕	↕	↕	↕	↘	↘	↘	↕	↕	
Caproic Acid	↕	↘	↕	↕	↕	↕	↕	↕	↕	↘	↘	↘	↕	↕	
Caproic Aldehyde		↗	↘	↘			↘	↗	↗	↗	↗		↕	↘	
Caprolactam	↕	↘	↕	↕	↕	↕	↕	↕	↕	↘	↘	↘	↕	↕	
Capronaldehyde	↕	↘	↕	↕	↕	↕	↕	↕	↕	↘	↘	↘	↕	↕	
Carbamate	→	↗	↕	↘	→	↕	↕		↕	↘	↘	↘	↕	↘	
Carbazole													↕		
Carbitol	↗	↗	↗	↘	↗	↗	↗	↗	↗	↗	↗	↗	↕	↘	
Carbolic Acid (Phenol)	↘	↗	↕	→	↘	↘	↕	↘	↕	↘	↘	↘	↕	↘	
Carbon Bisulfide	↘	↘	↕		↘	↘	↕	↘	↘	↘	↘	↘	↕	→	
Carbon Dioxide	↕	↕	↕	↕	↕	↕	↕	↕	↕	↕	↕	↕	↕	↕	↕
Carbon Dioxide (Explosive Decompression Use)	↕	↕	↕	↕	↕	↕	↕	↕	↕	↕	↕	↕	↕	↕	
Carbon Disulfide	↘	↘	↕		↘	↘	↕	↘	↘	↘	↘	↘	↕	→	↕
Carbon Fluorides	↗	↘	↕	↘	↗	↘	↕	↘	↘	↘	↘	↘	↕	↘	
Carbon Monoxide	↕	↕	↗	↕	↕	↕	↕	↕	↕	↕	↕	↕	↕		↕
Carbon Tetrabromide													↕		
Carbon Tetrachloride	↗	↘	↕	↘	↗	↘	↕	↘	↘	↘	↘	↘	↕	↘	↕
Carbon Tetrafluoride	↗	↘	↕	↘	↗	↘	↕	↘	↘	↘	↘	↘	↕	↘	

# Materials

Fluid	NBR	EPDM	FKM	TPU	HNBR	CR	FMQ	MQ	IIR	BR	IR	SBR	FFKM	ACM	PTFE
Carbonic Acid	↑	↑	↑	↑	↑	↑	↑	↑	↑	↑	↑	↑	↑	↓	
Casein	↑	↑	↑	↓	↑	↑	↑	↑	↑	↑	↑	↑	↑	↓	
Castor Oil	↑	↑	↑	↑	↑	↑	↑	↑	↑	↑	↑	↑	↑	↑	
Caustic Lime	→	↑	→	↓	→	↑	↑	↑	↑	↑	↑	↑	↑	↓	
Caustic Potash	→	↑	→	↓	→	↑	↑	↑	↑	↑	↑	↑	↑	↓	
Caustic Soda (Sodium Hydroxide)	→	↑	→	↓	→	↑	↑	↑	↑	↑	↑	↑	↑	↓	
Cellosolve	↓	↑	↓	↓	↓	↓	↓	↓	↑	↓	↓	↓	↑	↓	↑
Cellosolve, Acetate	↓	↑	↓	↓	↓	↓	↓	↓	↑	↓	↓	↓	↑	↓	
Cellosolve, Butyl	↓	↑	↓	↓	↓	↓	↓	↓	↑	↓	↓	↓	↑	↓	
Celluguard	↑	↑	↑	↑	↑	↑	↑	↑	↑	↑	↑	↑	↑	→	
Cellulose Acetate	→	↑	→	↑	↓	↑	↑	↑	↑	↑	↑	↑	↑	↓	
Cellulose Acetate Butyrate	→	↑	→	↓	→	↑	↑	↑	↑	↑	↑	↑	↑	↓	
Cellulose Ether	→	↑	→	↓	→	↑	↑	↑	↑	↑	↑	↑	↑	↓	
Cellulose Nitrate *	→	↑	→	↓	→	↑	↑	↑	↑	↑	↑	↑	↑	↓	
Cellulose Tripropionate	→	↑	→	↓	→	↑	↑	↑	↑	↑	↑	↑	↑	↓	
Cellulube (Phosphate Esters)													↑		
Cellutherm 2505A	↑	↓	↑	↓	↑	↓	↑	↓	↓	↓	↓	↓	↑	↑	
Cerium Sulfate	→	↑	→	↓	→	↑	↑	↑	↑	↑	↑	↑	↑	↓	
Cerous Chloride	→	↑	→	↓	→	↑	↑	↑	↑	↑	↑	↑	↑	↓	
Cerous Fluoride	→	↑	→	↓	→	↑	↑	↑	↑	↑	↑	↑	↑	↓	
Cerous Nitrate	→	↑	→	↓	→	↑	↑	↑	↑	↑	↑	↑	↑	↓	
Cetane (Hexadecane)	↑	↓	↑	↓	↑	↑	→	↓	↓	↓	↓	↓	↑	↑	

Fluid	NBR	EPDM	FKM	TPU	HNBR	CR	FMQ	MQ	IIR	BR	IR	SBR	FFKM	ACM	PTFE
Cetyl Alcohol	↑	↓	↑	↑	↑	↑	↑	↑	↓	↓	↓	↓	↑	↑	
Chaulmoogric Acid													↑		
China Wood Oil (Tung Oil)	↑	↓	↑	→	↑	↑	↑	↓	→	↓	↓	↓	↑		
Chloral	→	↑	→	↓	→	↑	↑	↑	↑	↑	↑	↑	↑	↓	
Chloramine													↑	↑	
Chloranthraquinone	↑	↓	↑	→	↑	↓	↑		↓	↓	↓	↓	↑	↓	
Chlordane	↑	↓	↑		↑	→	↑	↓	↓	↓	↓	↓	↑		
Chlorextol	↑	↓	↑	↓	↑	↑	↑	↓	↓	↓	↓	↓	↑	↑	
Chloric Acid	↓	↑	↑	↓	↓	↓	↑	↑	↑	↑	↑	↑	↑	↓	↑
Chlorinated Solvents, Dry	↓	↓	↑	↓	↓	↓	↑	↓	↓	↓	↓	↓	↑	↓	
Chlorinated Solvents, Wet	↓	↓	↑	↓	↓	↓	↑	↓	↓	↓	↓	↓	↑	↓	
Chlorine (Dry)	↑	↓	↑	→	↑	↓	↑		↓	↓	↓	↓	↑	↓	↑
Chlorine (Plasma)													↑		
Chlorine (Wet)													↑	↑	
Chlorine Dioxide	↓	→	↑	↓	↓	↓	↑		→	↓	↓	↓	↑	↓	
Chlorine Dioxide, 8% Cl as NaClO2 in solution	↓	↓	↑	↓	↓	↓	↑		↓	↓	↓	↓	↑	↓	
Chlorine Trifluoride	↓	↓	↓	↓	↓	↓	↓	↓	↓	↓	↓	↓	↑	↓	
Chlorine Water	↓	↑	↑	↓	↓								↑	↓	↑
Chloro 1-Nitro Ethane (1-Chloro 1-Nitro Ethane)	↓	↓	↓	↓	↓	↓	↓	↓	↓	↓	↓	↓	↑	↓	
Chloro Oxyfluorides													↑		
Chloro Xylenols	↑	↓	↑	→	↑	↓	↑		↓	↓	↓	↓	↑	↓	
Chloro Acetaldehyde	↓	↑	↓	↓	↓	↓	↑	↑	↑	↑	↑	↑	↑	↓	

Fluid	NBR	EPDM	FKM	TPU	HNBR	CR	FMQ	MQ	IIR	BR	IR	SBR	FFKM	ACM	PTFE
Chloroacetic Acid	↓	↑	↓	↓	↓	↓	↓		↑	↓	↓	↓	↑	↓	↑
Chloroacetone	↓	↑	↓	↓	↓	↓	↓	↓	↑	↓	↓	↓	↑	↑	
Chloroacetyl Chloride													↑		
Chloroamino Benzoic Acid	→	↑	→	↓	→	↑	↑	↑	↑	↑	↑	↑	↑	↓	
Chloroaniline	→	↑	→	↓	→	↑	↑	↑	↑	↑	↑	↑	↑	↓	
Chlorobenzaldehyde	→	↑	→	↓	→	↑	↑	↑	↑	↑	↑	↑	↑	↓	
Chlorobenzene	↓	↓	↑	↓	↓	↓	↑	↓	↓	↓	↓	↓	↑	↓	↑
Chlorobenzene (Mono)	↓	↓	↑	↓	↓	↓	↑	↓	↓	↓	↓	↓	↑	↓	
Chlorobenzene Chloride	↑	↑	↑	→	↑	↓	↑		↓	↓	↓	↓	↑	↓	
Chlorobenzene Trifluoride	↑	↓	↑	→	↑	↓	↑		↓	↓	↓	↓	↑	↓	
Chlorobenzochloride	↑	↓	↑	→	↑	↓	↑		↓	↓	↓	↓	↑	↓	
Chlorobenzotrifluoride	↑	↓	↑	→	↑	↓	↑		↓	↓	↓	↓	↑	↓	
Chlorobromo Methane	↓	↑	↑	↓	↓	↓	↑	↓	↑	↓	↓	↓	↑	↓	
Chlorobromopropane	↑	↓	↑	→	↑	↓	↑		↓	↓	↓	↓	↑	↓	
Chlorobutadiene	↓	↓	↑	↓	↓	↓	↑	↓	↓	↓	↓	↓	↑	↓	
Chlorobutane (Butyl Chloride)	↑	↓	↑	↑	↑	↑	↑	↑	↓	↓	↓	↓	↑	↑	
Chlorododecane	↓	↓	↑	↓	↓	↓	↑	↓	↓	↓	↓	↓	↑	↓	
Chloroethane	↑	↓	↑	↑	↑	↑	↑	↑	↓	↓	↓	↓	↑	↑	
Chloroethane Sulfonic Acid	→	↑	→	↓	→	↑	↑	↑	↑	↑	↑	↑	↑	↓	
Chloroethylbenzene	↑	↓	↑	→	↑	↓	↑		↓	↓	↓	↓	↑	↓	
Chloroform	↓	↓	↑	↓	↓	↓	↓	↓	↓	↓	↓	↓	↑	↓	↑
Chlorohydrin	→	↑	→	↓	→	↑	↑	↑	↑	↑	↑	↑	↑	↓	



# Materials

Fluid	NBR	EPDM	FKM	TPU	HNBR	CR	FMQ	MQ	IR	BR	IR	SBR	FFKM	ACM	PTFE
Chloronaphthalene or o-Chloronaphthalene	↓	↓	↑	↓	↓	↓	↓	↓	↓	↓	↓	↓	↑	↓	
Chloronitrobenzene	→	↑	→	↓	→	↑	↑	↓	↑	↑	↑	↑	↑	↓	
Chlorophenol or o-Chlorophenol	↓	↓	↑	↓	↓	↓	↓	↓	↓	↓	↓	↓	↑	↓	
Chloropicrin	↑	↓	↑	→	↑	↓	↓	↓	↓	↓	↓	↓	↑	↓	
Chloroprene	↑	↓	↑	→	↑	↓	↓	↓	↓	↓	↓	↓	↑	↓	
Chlorosilanes													↑		
Chlorosulfonic Acid	↓	→	↓	↓	↓	↓	↓	↓	↓	↓	↓	↓	↑	↓	↑
Chlorotoluene	↓	↓	↑	↓	↓	↓	↓	↓	↓	↓	↓	↓	↑	↓	
Chlorotoluene Sulfonic Acid	→	↑	→	↓	→	↑	↑	↓	↑	↑	↑	↑	↑	↓	
Chlorotoluidine	↑	↓	↑	→	↑	↓	↓	↓	↓	↓	↓	↓	↑	↓	
Chlorotrifluoroethylene (CTFE)													↑		
Chlorox	↑	↑	↑	↓	↑	↑	↑	↓	↓	↓	↓	↓	↑	↓	
Chloroxylols													↑		
Cholesterol	↑	↓	↑	→	↑	↓	↓	↓	↓	↓	↓	↓	↑	↓	
Chrome Alum	↑	↑	↑		↑	↑	↑	↑	↑	↑	↑	↑	↑	↓	
Chrome Plating Solutions	↓	↑	↑	↓	↓	↓	↓	↓	↓	↓	↓	↓	↑	↓	
Chromic Acid	↓	↑	↑	↓	↓	↓	↓	↓	↓	↓	↓	↓	↑	↓	↑
Chromic Chloride													↑		
Chromic Fluorides													↑		
Chromic Hydroxide													↑		
Chromic Nitrates													↑		
Chromic Oxide	↓	↑	↑		↓	↓							↑		

Fluid	NBR	EPDM	FKM	TPU	HNBR	CR	FMQ	MQ	IR	BR	IR	SBR	FFKM	ACM	PTFE
Chromic Phosphate													↑		
Chromic Sulfate													↑		
Chromium Potassium Sulfate (Alum)	↑	↑	↑										↑		
Chromyl Chlorides													↑		
Cinnamic Acid	↑	↓	↑	→	↑	↓	↓	↓	↓	↓	↓	↓	↑	↓	
Cinnamic Alcohol	↑	↓	↑	→	↑	↓	↓	↓	↓	↓	↓	↓	↑	↓	
Cinnamic Aldehyde	↑	↓	↑	→	↑	↓	↓	↓	↓	↓	↓	↓	↑	↓	
Citric Acid	↑	↑	↑	↓	↑	↑	↑	↑	↑	↑	↑	↑	↑	↓	↑
City Service #65 #120 #250	↑	↓	↑	↑	↑	↑	↓	↓	↓	↓	↓	↓	↑	↑	
City Service Koolmoter-AP Gear Oil 140-EP Lube	↑	↓	↑	↑	↑	↑	↓	↓	↓	↓	↓	↓	↑	↑	
City Service Pacemaker #2	↑	↓	↑	↑	↑	↑	↓	↓	↓	↓	↓	↓	↑	↑	
Coal Tar	↑	↓	↑	↓	↑								↑		
Cobalt Chloride	↑	↑	↑	↑	↑	↑	↑	↑	↑	↑	↑	↑	↑	↑	
Cobalt Chloride, 2N	↑	↑	↑	↓	↑	↑	↑	↑	↑	↑	↑	↑	↑	↓	
Cobaltous Acetate	→	↑	→	↓	→	↑	↑	↑	↑	↑	↑	↑	↑	↓	
Cobaltous Bromide	↑	↑	↑	↓	↑	↑	↑	↑	↑	↑	↑	↑	↑	↓	
Cobaltous Linoleate													↑		
Cobaltous Naphthenate													↑		
Cobaltous Sulfate	→	↑	→	↓	→	↑	↑	↑	↑	↑	↑	↑	↑	↓	
Coconut Oil	↑	↓	↑	↑	↑	↑	↑	↑	→	↓	↓	↓	↑	↑	↑
Cod Liver Oil	↑	↑	↑	↑	↑	↑	↑	↑	↓	↓	↓	↓	↑	↑	↑
Codeine	↑	↓	↑	→	↑	↓	↓	↓	↓	↓	↓	↓	↑	↓	

Fluid	NBR	EPDM	FKM	TPU	HNBR	CR	FMQ	MQ	IR	BR	IR	SBR	FFKM	ACM	PTFE
Coffee	↑	↑	↑	↓	↑	↑	↑	↑	↑	↑	↑	↑	↑	↓	
Coke Oven Gas	↓	↓	↑	↓	↓	↓	↓	↓	↓	↓	↓	↓	↑	↓	
Convelex 10	↓			↑	↓	↓	↓	↓	↓	↓	↓	↓			
Coolanol 20 25R 35R 40& 45A (Monsanto)	↑	→	↑	↑	↑	↑	↓	↓	↓	↓	↓	↓	↑	↓	
Copper Acetate	↑	↑	↓	↓	↑	↑	↓	↓	↑	↓	↓	↓	↑	↓	
Copper Ammonium Acetate	↓	↑	↓	↓	↓	→	↑	↑	↑	↑	↑	↑	↑	↓	
Copper Carbonate	→	↑	→	↓	→	↑	↑	↑	↑	↑	↑	↑	↑	↓	
Copper Chloride	↑	↑	↑	↑	↑	↑	↑	↑	↑	↑	↑	↑	↑	↑	↑
Copper Cyanide	↑	↑	↑	↑	↑	↑	↑	↑	↑	↑	↑	↑	↑	↑	
Copper Gluconate	→	↑	→	↓	→	↑	↑	↑	↑	↑	↑	↑	↑	↓	
Copper Naphthenate													↑		
Copper Nitrate	↑	↑	↑	↓	↑	↑							↑	↓	↑
Copper Oxide	↑	↑	↑	↑	↑	↑	↑	↑	↑	↑	↑	↑	↑	↑	
Copper Salts	↑	↑	↑	↑	↑	↑	↑	↑	↑	↑	↑	↑	↑	↑	
Copper Sulfate	↑	↑	↑	↑	↑	↑	↑	↑	↑	↑	↑	↑	↑	↓	↑
Copper Sulfate 10%	↑	↑	↑	↑	↑	↑	↑	↑	↑	↑	↑	↑	↑	↓	↑
Copper Sulfate 50%	↑	↑	↑	→	↑	↑	↑	↑	↑	↑	↑	↑	↑	↓	↑
Corn Oil	↑	↓	↑	↑	↑	↑	↑	↑	→	↓	↓	↓	↑	↑	↑
Cottonseed Oil	↑	↓	↑	↑	↑	↑	↑	↑	→	↓	↓	↓	↑	↑	↑
Creosote, Coal Tar	↑	↓	↑	→	↑	↑	↓	↓	↓	↓	↓	↓	↑	↑	
Creosote, Wood	↑	↓	↑	→	↑	↑	↓	↓	↓	↓	↓	↓	↑	↑	
Cresol (Methyl Phenol)			↑										↑		

# Materials

Fluid	NBR	EPDM	FKM	TPU	HNBR	CR	FMQ	MQ	IIR	BR	IR	SBR	FFKM	ACM	PTFE
Cresols	↓	↓	↗		↓	↓		↓	↓	↓	↓	↓	↑	↓	↑
Cresylic Acid	↓	↓	↑	↓	↓	↓		↓	↓	↓	↓	↓	↑	↓	
Crotonaldehyde	↓	↑	↓	↗	↓	↓	↗		↓	↓	↓	↓	↑	↓	↑
Crotonic Acid	↗	↓	↑	↗	↗	↗		↓	↓	↓	↓	↓	↑	↓	
Crude Oil	↗	↓	↑	↓	↗	↓	↗	↓	↓	↓	↓	↓	↑		↑
Cumaldehyde	↗	↓	↑	↗	↗	↗		↓	↓	↓	↓	↓	↑	↓	
Cumene	↓	↓	↑	↓	↓	↓	↗	↓	↓	↓	↓	↓	↑	↓	
Cumene Hydroperoxide													↑		
Cupric Sulfate	↗	↗	↑										↑		
Cutting Oil	↑	↓	↑	↑	↑	↗	↑	↓	↓	↓	↓	↓	↑	↑	
Cyanamide													↑		
Cyanides													↑		
Cyanogen Chloride													↑		
Cyanogen Gas													↑		
Cyanohydrin													↑		
Cyanuric Chloride													↑		
Cyclohexane	↑	↓	↑	↑	↑	↗	↑	↓	↓	↓	↓	↓	↑	↗	↑
Cyclohexanol	↑	↓	↑		↑	↗	↑	↓	↓	↓	↓	↓	↑		↑
Cyclohexanone	↓	↓	↓	↓	↓	↓	↓	↓	↗	↓	↓	↓	↑	↓	↑
Cyclohexene	↗	↓	↑	↗	↗	↗		↓	↓	↓	↓	↓	↑	↓	
Cyclohexylamine	↓	↗	↓	↓	↓	↓	↑	↗	↓	↓	↓	↓	↑	↓	↑
Cyclohexylamine Carbonate													↑		

Fluid	NBR	EPDM	FKM	TPU	HNBR	CR	FMQ	MQ	IIR	BR	IR	SBR	FFKM	ACM	PTFE
Cyclohexylamine Laurate	↑	↓	↑	↑	↑	↗	↑	↗	↓	↓	↓	↓	↑	↑	
Cyclopentadiene	↗	↓	↑	↗	↗	↗			↓	↓	↓	↓	↑	↓	
Cyclopentane	↑	↓	↑	↑	↑	↗	↑	↓	↓	↓	↓	↓	↑	↗	
Cyclopolyolefins	↑	↓	↑	↑	↑	↗	↑	↓	↓	↓	↓	↓	↑	↗	
Cymene or p-Cymene	↓	↓	↓	↓	↓	↗	↓	↓	↓	↓	↓	↓	↑	↓	
DDT (Dichlorodiphenyltrichloroethane)	↗	↓	↑	↗	↗	↗			↓	↓	↓	↓	↑	↓	
Decalin	↓	↓	↑		↓	↓	↑	↓	↓	↓	↓	↓	↑		
Decane	↑	↓	↑	↓	↑	↓	↑	↗	↓	↓	↓	↓	↑	↑	
Delco Brake Fluid	↗	↑	↓		↗	↗	↓	↗				↑	↑		
Denatured Alcohol	↑	↑	↑	↓	↑	↑	↑	↑	↑	↑	↑	↑	↑	↓	
Detergent, Water Solution	↑	↑	↑	↓	↑	↑	↑	↑	↑	↗	↗	↗	↑	↓	↑
Developing Fluids	↑	↗	↑		↑	↑	↑	↑	↗	↗	↑	↑			
Dexron	↑	↓	↑	↗	↑	↗	↗	↓	↓	↓	↓	↓	↑	↑	
Dextrin	↑	↑	↑	↓	↑	↑	↑	↗	↓	↓	↓	↓	↑	↓	↑
Dextro Lactic Acid	↗	↑	↗	↓	↗	↗	↑	↑	↑	↑	↑	↑	↑	↓	
Dextron	↑	↓	↑		↑	↗							↑		
Dextrose	↗	↑	↗	↗	↗	↗	↑	↑	↑	↑	↑	↑	↑	↗	↑
DI Water	↗	↑	↗	↓		↑	↑	↗	↑	↑	↑	↑	↑	↓	
Di-ester Lubricant MIL-L-7808	↗	↓	↑	↓	↗	↗	↓	↓	↓	↓	↓	↓	↑	↗	
Di-ester Synthetic Lubricants	↗	↓	↑	↓	↗	↗	↓	↓	↓	↓	↓	↓	↑	↗	
Di-Tert-Butyl Peroxide													↑		
Diacetone	↓	↑	↓	↗	↓	↓	↓	↓	↑	↓	↓	↓	↑	↓	

Fluid	NBR	EPDM	FKM	TPU	HNBR	CR	FMQ	MQ	IIR	BR	IR	SBR	FFKM	ACM	PTFE
Diacetone Alcohol	↓	↑	↓	↓	↓	↗	↓	↓	↑	↓	↓	↓	↑	↓	↑
Dialkyl Sulfates	↗	↑	↗	↓	↗	↑	↑	↗	↑	↑	↑	↑	↑	↓	
Diallyl Ether													↑		
Diallyl Phthalate													↑		
Diamylamine	↗	↗	↓	↗	↗	↗	↑	↗	↓	↓	↓	↓	↑	↓	
Diazinon	↗	↓	↗		↗	↗	↗	↓	↓	↓	↓	↓	↑		
Dibenzyl (sym-Diphenylethane)	↗	↑	↑	↗	↗	↗			↓	↓	↓	↓	↑	↓	
Dibenzyl Ether	↓	↗	↗	↗	↓				↗	↓	↓	↓	↑	↗	↑
Dibenzyl Sebacate	↓	↗	↗	↗	↓		↗	↗	↓	↓	↓	↓	↑	↓	
Diborane													↑		
Dibromoethane	↗	↓	↑	↗	↗	↗	↑		↓	↓	↓	↓	↑	↓	
Dibromoethyl Benzene	↓	↑	↑	↓	↓	↗	↓	↓	↓	↓	↓	↓	↑	↓	
Dibutyl Cellosolve Adipate	↗	↑	↗	↓	↗	↑	↑	↗	↑	↑	↑	↑	↑	↓	
Dibutyl Ether	↓	↗	↗	↗	↓		↗	↗	↓	↓	↓	↓	↑	↗	↑
Dibutyl Methylene-dithio Glycolate	↗	↓	↑	↗	↗	↗	↑		↓	↓	↓	↓	↑	↓	
Dibutyl Phthalate	↓	↗	↗	↗	↓		↗	↗	↓	↓	↓	↓	↑	↓	↑
Dibutyl Sebacate	↓	↗	↗	↓	↓	↗	↗	↗	↓	↓	↓	↓	↑	↓	↑
Dibutyl Thioglycolate	↗	↑	↑	↗	↗	↗			↓	↓	↓	↓	↑	↓	
Dibutyl Thiourea	↗	↓	↑	↗	↗	↗			↓	↓	↓	↓	↑	↓	
Dibutylamine	↓	↓	↓	↓	↓	↗	↓	↗	↓	↓	↓	↓	↑	↓	
Dichloroacetic Acid	↗	↓	↗	↗	↗	↗	↑		↓	↓	↓	↓	↑	↓	↑
Dichloroaniline	↗	↑	↓	↗	↗	↑	↑	↗	↑	↑	↑	↑	↑	↓	

# Materials

Fluid	NBR	EPDM	FKM	TPU	HNBR	CR	FMQ	MQ	IIR	BR	IR	SBR	FFKM	ACM	PTFE
Dichlorobenzene or o-Dichlorobenzen	†	↓	↓	↓	↓	↓	↓	↓	↓	↓	↓	↓	↑	↓	↑
Dichlorobenzene or p-Dichlorobenzen	†	↓	↓	↓	↓	↓	↓	↓	↓	↓	↓	↓	↑	↓	↑
Dichlorobutane	↑	↓	↑	↓	↓	↓	↓	↓	↓	↓	↓	↓	↑	↓	
Dichlorobutene	↑	↓	↑	→	↓	↓		↓	↓	↓	↓	↓	↑	↓	
Dichlorodiphenyl-Dichloroethane (DDD)	↑	↓	↑	→	↓	↓		↓	↓	↓	↓	↓	↑	↓	
Dichloroethane	→	↓	↑	→	↓	↓		↓	↓	↓	↓	↓	↑	↓	↑
Dichloroethylene	→	↓	↑	↓	↓	↓		↓	↓	↓	↓	↓	↑	↓	↑
Dichlorohydrin	→	↑	→	↓	→	↑	↑	↑	↑	↑	↑	↑	↑	↓	
Dichloroisopropyl Ether	↓	→	→	↑	↓	↓	→	↓	↓	↓	↓	↓	↑	→	
Dichloromethane	→	↓	↑	→	↓	↓		↓	↓	↓	↓	↓	↑	↓	↑
Dichlorophenol	↑	↓	↑	→	↓	↓		↓	↓	↓	↓	↓	↑	↓	
Dichlorophenoxyacetic Acid	↑	↓	↑	→	↓	↓		↓	↓	↓	↓	↓	↑	↓	
Dichloropropane	↑	↓	↑	→	↓	↓		↓	↓	↓	↓	↓	↑	↓	
Dichloropropene	↑	↓	↑	→	↓	↓		↓	↓	↓	↓	↓	↑	↓	
Dichlorosilane													↑		
Dicyclohexylamine	↓	↓	↓	↓	↓	↓	↓	↓	↓	↓	↓	↓	↑	↓	
Dicyclohexylammonium Nitrate	→	↑	→	↓	→	↑	↑	↑	↑	↑	↑	↑	↑	↓	
Dieldrin	↑	↓	↑	→	↓	↓		↓	↓	↓	↓	↓	↑	↓	
Diesel Fuel	↑	↓	↑	↑	↓	↓	↓	↓	↓	↓	↓	↓	↑	↓	↑
Diethanolamine (DEA)	→	↑	→	↓	→	↓	↑	↑	↑	↑	↑	↑	↑	↓	
Diethyl Benzene	↓	↓	↑	↓	↓								↑	↓	
Diethyl Carbonate	→	→	→	↓	→	↑	↑	↑	↑	↑	↑	↑	↑	↓	

Fluid	NBR	EPDM	FKM	TPU	HNBR	CR	FMQ	MQ	IIR	BR	IR	SBR	FFKM	ACM	PTFE
Diethyl Ether	↓	↓	↓	↑	↓	→	→	↓	↓	↓	↓	↓	↑	→	↑
Diethyl Phthalate	↑	↓	↑	→	↓	↓		↓	↓	↓	↓	↓	↑	↓	
Diethyl Sebacate	↓	↑	↑	↓	↓	↓	↑	↑	↑	↓	↓	↓	↑	↓	↑
Diethyl Sulfate	↓	↑	↓	↓	↓		↑						↑		
Diethylamine	↓	↑	↓	↓	↓	→	↑	↑	↑	↑	↑	↑	↑	↓	↑
Diethylaniline	→	↑	→	↓	→	→	↑	↑	↑	↑	↑	↑	↑	↓	
Diethylene Glycol	↑	↑	↑	↓	↑	↑	↑	↑	↑	↑	↑	↑	↑	↓	↑
Diethylenetriamine	↓	↑	↓	↓	↓								↑	↓	
Difluorodibromomethane	↓	↑		↓	↓		↓	↑	↓	↓	↓	↓	↑	↓	
Difluoroethane	↑	↓	↑	→	↓	↓		↓	↓	↓	↓	↓	↑	↓	
Difluoromonoethane	↑	↓	↑	→	↓	↓		↓	↓	↓	↓	↓	↑	↓	
Diglycol Chloroformate	→	↑	→	↓	→	↑	↑	↑	↑	↑	↑	↑	↑	↓	
Diglycolic Acid	→	↑	↑	↓	→	↑	↑	↑	↑	↑	↑	↑	↑	↓	↑
Dihydroxydiphenylsulfone	→	↑	→	↓	→	↑	↑	↑	↑	↑	↑	↑	↑	↓	
Diisobutyl Ketone	↓	↑	↓	↓	↓				↑				↑	↓	↑
Diisobutylcarbinol	↑	↓	↑	↑	↑	↑	↑	↑	↓	↓	↓	↓	↑	↑	
Diisobutylene	↑	↓	↑	↓	↓	→	↓	↓	↓	↓	↓	↓	↑	↓	
Diisooctyl Sebacate	→	→	↑	↓	→	↓	→	→	↓	↓	↓	↓	↑	↓	
Diisopropyl Ether (DIPE)													↑		
Diisopropyl Ketone	↓	↑	↓	↓	↓	↓	↓	↓	↑	↓	↓	↓	↑	↓	
Diisopropylbenzene	↓	↓	↑	↓	↓	↓	↑		↓	↓	↓	↓	↑	↓	
Diisopropylidene Acetone	↑	↓	↑	→	↓	↓		↓	↓	↓	↓	↓	↑	↓	

Fluid	NBR	EPDM	FKM	TPU	HNBR	CR	FMQ	MQ	IIR	BR	IR	SBR	FFKM	ACM	PTFE
Dimethyl Acetamide	→	↑	→	↓	→	↑	↑	↑	↑	↑	↑	↑	↑	↓	
Dimethyl Ether	↓	↑	↓	↑	↓								↑	↓	
Dimethyl Formaldehyde	→	↑	→	↓	→	↑	↑	↑	↑	↑	↑	↑	↑	↓	
Dimethyl Formamide (DMF)	↑	↑	↓	↓	↑	↓	↓	↑	↑				↓	↑	↓
Dimethyl Phenyl Carbinol	↑	↓	↑	→	↓	↓		↓	↓	↓	↓	↓	↑	↓	
Dimethyl Phenyl Methanol	↑	↓	↑	→	↓	↓		↓	↓	↓	↓	↓	↑	↓	
Dimethyl Phthalate	↓	↑	↑		↓	↓	↑		↑	↓	↓	↓	↑	↓	
Dimethyl Sulfoxide (DMSO)	→	↑	→	↓	→	↑	↑	↑	↑	↑	↑	↑	↑	↓	
Dimethyl Terephthalate (DMT)	↑	↓	↑	→	↓	↓		↓	↓	↓	↓	↓	↑	↓	
Dimethylamine (DMA)	↓	↑	↓	→	↓	↓	↓	↑	↑	↑	↑	↑	↑	↓	↑
Dimethylaniline (Xylidine)	↓	→	→	↓	↓	↓		↓	↓	↓	↓	↓	↑	↓	
Dimethyldisulfide (DMDS)	↑	↓	↑	↑	↑	↑	↑	↑	↓	↓	↓	↓	↑	↑	
Dimethylhydrazine	↑	↑	→	↓	↑	↑	↑	↑	↑	↑	↑	↑	↑	↓	
Dinitrochlorobenzene	↑	↓	↑	→	↓	↓		↓	↓	↓	↓	↓	↑	↓	
Dinitrogen Tetroxide													↑		
Dinitrotoluene (DNT)	↓	↓	↓	↓	↓	↓	↓	↓	↓	↓	↓	↓	↑	↓	
Diocetyl Phthalate	↓	↑	↑	→	↓	↓	↑	→	↑	↓	↓	↓	↑	↓	↑
Diocetyl Sebacate	↓	↑	↑	↑	↓	↓	→	→	↑	↓	↓	↓	↑	↓	↑
Diocetylamine	↑	↓	↑	↑	↑	↑	↑	↑	↓	↓	↓	↓	↑	↑	
Dioxane	↓	↑	↓	↓	↓	↓	↓	↓	↑	↓	↓	↓	↑	↓	↑
Dioxolane	↓	↑	↓	↓	↓	↓	↓	↓	→	↓	↓	↓	↑	↓	
Dipentene	↑	↓	↑	↓	↑	↓	↓	↓	↓	↓	↓	↓	↑	↓	↑

# Materials

Fluid	NBR	EPDM	FKM	TPU	HNBR	CR	FMQ	MQ	IIR	BR	IR	SBR	FFKM	ACM	PTFE
Diphenyl	↓	↓	↑	↓	↓	↓	↓	↓	↓	↓	↓	↓	↓	↓	↓
Diphenyl Oxides	↓	↓	↑	↓	↓	↓	↓	↓	↓	↓	↓	↓	↓	↓	↓
Diphenylamine (DPA)	↓	↓	↑	↓	↓	↓	↓	↓	↓	↓	↓	↓	↓	↓	↓
Diphenylene Oxide													↑		
Diphenylpropane	↓	↓	↑	↓	↓	↓	↓	↓	↓	↓	↓	↓	↓	↓	↓
Disilane													↑		
Dodecylbenzene	↓	↓	↑	↓	↓	↓	↓	↓	↓	↓	↓	↓	↓	↓	↓
Dow Chemical 50-4	↑	↓		↓	↓	↓	↓	↓	↓	↓	↓	↓	↓	↓	↓
Dow Chemical ET378	↓			↓	↓	↓	↓	↓	↓	↓	↓	↓	↓	↓	↓
Dow Chemical ET588	→	↑	↓	→	↓	↓	↓	↓	↓	↓	↓	↓	↓	↓	↓
Dow Corning -11	↓	↓	↓	↓	↓	↓	↓	↓	↓	↓	↓	↓	↓	↓	↓
Dow Corning -1265 Fluorosilicone Fluid	↓	↓	↓	↓	↓	↓	↓	↓	↓	↓	↓	↓	↓	↓	↓
Dow Corning -200	↓	↓	↓	↓	↓	↓	↓	↓	↓	↓	↓	↓	↓	↓	↓
Dow Corning -220	↓	↓	↓	↓	↓	↓	↓	↓	↓	↓	↓	↓	↓	↓	↓
Dow Corning -3	↓	↓	↓	↓	↓	↓	↓	↓	↓	↓	↓	↓	↓	↓	↓
Dow Corning -33	↓	↓	↓	↓	↓	↓	↓	↓	↓	↓	↓	↓	↓	↓	↓
Dow Corning -4	↓	↓	↓	↓	↓	↓	↓	↓	↓	↓	↓	↓	↓	↓	↓
Dow Corning -44	↓	↓	↓	↓	↓	↓	↓	↓	↓	↓	↓	↓	↓	↓	↓
Dow Corning -5	↓	↓	↓	↓	↓	↓	↓	↓	↓	↓	↓	↓	↓	↓	↓
Dow Corning -510	↓	↓	↓	↓	↓	↓	↓	↓	↓	↓	↓	↓	↓	↓	↓
Dow Corning -55	↓	↓	↓	↓	↓	↓	↓	↓	↓	↓	↓	↓	↓	↓	↓
Dow Corning -550	↓	↓	↓	↓	↓	↓	↓	↓	↓	↓	↓	↓	↓	↓	↓

Fluid	NBR	EPDM	FKM	TPU	HNBR	CR	FMQ	MQ	IIR	BR	IR	SBR	FFKM	ACM	PTFE
Dow Corning -704	↓	↓	↓	↓	↓	↓	↓	↓	↓	↓	↓	↓	↓	↓	↓
Dow Corning -705	↓	↓	↓	↓	↓	↓	↓	↓	↓	↓	↓	↓	↓	↓	↓
Dow Corning -710	↓	↓	↓	↓	↓	↓	↓	↓	↓	↓	↓	↓	↓	↓	↓
Dow Corning 1208, 4050, 6620, F-60, XF-60	↓	↓	↓	↓	↓	↓	↓	↓	↓	↓	↓	↓	↓	↓	↓
Dow Corning F-61	↓	↓	↓	↓	↓	↓	↓	↓	↓	↓	↓	↓	↓	↓	↓
Dow Guard	↓	↓	↓	↓	↓	↓	↓	↓	↓	↓	↓	↓	↓	↓	↓
Dowanol P Mix															
Dowtherm, 209	→	↓	↓	→	↓	↓	↓	↓	↓	↓	↓	↓	↓	↓	↓
Dowtherm, A	↓	↓	↓	↓	↓	↓	↓	↓	↓	↓	↓	↓	↓	↓	↓
Dowtherm, E	↓	↓	↓	↓	↓	↓	↓	↓	↓	↓	↓	↓	↓	↓	↓
Drinking Water	↓	↓	↓	↓	↓	↓	↓	↓	↓	↓	↓	↓	↓	↓	↓
Dry Cleaning Fluids	→	↓	↓	→	↓	↓	↓	↓	↓	↓	↓	↓	↓	↓	↓
DTE 20 Series, Mobil	↓	↓	↓	↓	↓	↓	↓	↓	↓	↓	↓	↓	↓	↓	↓
DTE named series, Mobil, light-heavy	↓	↓	↓	↓	↓	↓	↓	↓	↓	↓	↓	↓	↓	↓	↓
Elco 28-EP lubricant	↓	↓	↓	↓	↓	↓	↓	↓	↓	↓	↓	↓	↓	↓	↓
Epichlorohydrin	↓	↓	↓	↓	↓	↓	↓	↓	↓	↓	↓	↓	↓	↓	↓
Epoxy Resins		↓													
Erucic Acid															
Esam-6 Fluid		↓		↓	↓	↓	↓	↓	↓	↓	↓	↓	↓	↓	↓
Esso Fuel 208	↓	↓	↓	↓	↓	↓	↓	↓	↓	↓	↓	↓	↓	↓	↓
Esso Golden Gasoline	↓	↓	↓	↓	↓	↓	↓	↓	↓	↓	↓	↓	↓	↓	↓
Esso Motor Oil	↓	↓	↓	↓	↓	↓	↓	↓	↓	↓	↓	↓	↓	↓	↓

Fluid	NBR	EPDM	FKM	TPU	HNBR	CR	FMQ	MQ	IIR	BR	IR	SBR	FFKM	ACM	PTFE
Esso Transmission Fluid (Type A)	↓	↓	↓	↓	↓	↓	↓	↓	↓	↓	↓	↓	↓	↓	↓
Esso WS2812 (MIL-L-7808A)	↓	↓	↓	↓	↓	↓	↓	↓	↓	↓	↓	↓	↓	↓	↓
Esso XP90-EP Lubricant	↓	↓	↓	↓	↓	↓	↓	↓	↓	↓	↓	↓	↓	↓	↓
Esstic 42, 43	↓	↓	↓	↓	↓	↓	↓	↓	↓	↓	↓	↓	↓	↓	↓
Ethane	↓	↓	↓	↓	↓	↓	↓	↓	↓	↓	↓	↓	↓	↓	↓
Ethanol	→	↓	↓	→	↓	↓	↓	↓	↓	↓	↓	↓	↓	↓	↓
Ethanol Amine	→	↓	↓	→	↓	↓	↓	↓	↓	↓	↓	↓	↓	↓	↓
Ethers	↓	↓	↓	↓	↓	↓	↓	↓	↓	↓	↓	↓	↓	↓	↓
Ethoxyethyl Acetate (EGMEA)	→	↓	↓	→	↓	↓	↓	↓	↓	↓	↓	↓	↓	↓	↓
Ethyl Acetate	↓	↓	↓	↓	↓	↓	↓	↓	↓	↓	↓	↓	↓	↓	↓
Ethyl Acetate-Organic Ester	↓	↓	↓	↓	↓	↓	↓	↓	↓	↓	↓	↓	↓	↓	↓
Ethyl Acrylate	↓	↓	↓	↓	↓	↓	↓	↓	↓	↓	↓	↓	↓	↓	↓
Ethyl Alcohol	→	↓	↓	→	↓	↓	↓	↓	↓	↓	↓	↓	↓	↓	↓
Ethyl Ammonium Dichloride															
Ethyl Benzene	↓	↓	↓	↓	↓	↓	↓	↓	↓	↓	↓	↓	↓	↓	↓
Ethyl Benzoate	↓	↓	↓	↓	↓	↓	↓	↓	↓	↓	↓	↓	↓	↓	↓
Ethyl Bromide	↓	↓	↓	↓	↓	↓	↓	↓	↓	↓	↓	↓	↓	↓	↓
Ethyl Cellosolve	↓	↓	↓	↓	↓	↓	↓	↓	↓	↓	↓	↓	↓	↓	↓
Ethyl Cellulose	↓	↓	↓	↓	↓	↓	↓	↓	↓	↓	↓	↓	↓	↓	↓
Ethyl Chloride	↓	↓	↓	↓	↓	↓	↓	↓	↓	↓	↓	↓	↓	↓	↓
Ethyl Chlorocarbonate	↓	↓	↓	↓	↓	↓	↓	↓	↓	↓	↓	↓	↓	↓	↓
Ethyl Chloroformate	↓	↓	↓	↓	↓	↓	↓	↓	↓	↓	↓	↓	↓	↓	↓

# Materials

Fluid	NBR	EPDM	FKM	TPU	HNBR	CR	FMQ	MQ	IR	BR	IR	SBR	FFKM	ACM	PTFE
Ethyl Ether	→	→	↓	↗	→	↓	→	↓	→	↓	↓	↓	↑	↓	
Ethyl Formate	↓	↗	↑		↓	↗	↑		↗	↓	↓	↓	↑		
Ethyl Hexanol	↑	↑	↑	↓	↑	↑	↑	↗	↑	↑	↑	↑	↑	↓	
Ethyl Lactate	→	↑	→	↓	→	↑	↑	↗	↑	↑	↑	↑	↑	↓	
Ethyl Mercaptan	↓		↗		↓	→		→	↓	↓	↓	↓	↑		
Ethyl Nitrite	→	↑	→	↓	→	↑	↑	↗	↑	↑	↑	↑	↑	↓	
Ethyl Oxalate	↓	↗	↑	↑	↓	↓	↗	↓	↓	↓	↓	↓	↑	↓	
Ethyl Pentachlorobenzene	↓	↓	↑	↓	↓	↓	↗	↓	↓	↓	↓	↓	↑	↓	
Ethyl Pyridine	↗	↑	↓	↓	↓	↓	↗		↓	↓	↓	↓	↑	↓	
Ethyl Silicate	↑	↑	↑		↑	↑	↑		↑	↗	↗	↗	↑		
Ethyl Stearate	↗	↓	↑	→	↗	↓	↗		↓	↓	↓	↓	↑	↓	
Ethyl Sulfate	↓	↑	↓	↓	↓	↑							↑	↓	
Ethyl Tertiary Butyl Ether													↑		
Ethyl Valerate	↗	↓	↑	→	↗	↓	↗		↓	↓	↓	↓	↑	↓	
Ethylacrylic Acid	↓	↗		↓	↓	↗	↓	↓	↗	↓	↓	↓		↓	
Ethylamine	→	↑	→	↓	→	↑	↑	↗	↑	↑	↑	↑	↑	↓	
Ethylcyclopentane	↑	↓	↑	↑	↑	→	↑	↓	↓	↓	↓	↓	↑	↗	
Ethylene	↗	↓	↑	↗	↗	↓	↗	↓	↓	↓	↓	↓	↑	↗	
Ethylene Chloride	↓	↗	↗	↓	↓	↗	↗	↓	↓	↓	↓	↓	↑	↓	↑
Ethylene Chlorohydrin	↓	↗	↓	↓	↓	↗	↗	→	↗	↗	↗	↗	↑	↓	↑
Ethylene Cyanohydrin	↗	↓	↑	→	↗	↓	↗		↓	↓	↓	↓	↑	↓	
Ethylene Diamine	↓	↑	↓	↓	↓	↓	↑	↑	↗	↑	↑	↗	↓	↑	

Fluid	NBR	EPDM	FKM	TPU	HNBR	CR	FMQ	MQ	IR	BR	IR	SBR	FFKM	ACM	PTFE
Ethylene Dibromide	↓	↓	↑	↓	↓	↓	→	↓	→	↓	↓	↓	↑	↓	
Ethylene Dichloride	↓	↓	↑	↓	↓	↓	→	↓	→	↓	↓	↓	↑	↓	
Ethylene Glycol	↑	↑	↑	↗	↑	↗	↑	↑	↑	↑	↑	↑	↑	→	↑
Ethylene Hydrochloride	↓	→	↑	↓	↓	↓	→	↓	→	↓	↓	↓	↑	↓	
Ethylene Oxide	↓	↗	↓	↓	↓	↓	↓	↓	→	↓	↓	↓	↑	↓	
Ethylene Oxide, (12% and Freon 12 (80%))	→	↗	↓	↓	→	↓	↓	↓	↗	↓	↓	↓	↗	↓	
Ethylene Trichloride	↓	→	↑	↓	↓	↓	→	↓	→	↓	↓	↓	↑	↓	↑
Ethyleneimine													↑		
Ethylmorpholene Stannous Octoate (50/50 mixture)	↓	↗	↓		↓				↗			↓	↑		
Ethylmorpholine	↗	↓	↑	→	↗	↓	↗		↓	↓	↓	↓	↑	↓	
Ethylsulfuric Acid	→	↑	→	↓	→	↑	↑	↗	↑	↑	↑	↑	↑	↓	
F-60 Fluid (Dow Corning)	↑	↑	↑	↑	↑	↑	↑	↓	↑	↑	↑	↑	↑	↑	
F-61 Fluid (Dow Corning)	↑	↑	↑	↑	↑	↑	↑	↓	↑	↑	↑	↑	↑	↑	
Fatty Acids	↗	→	↑		↗	↗		→	→	↓	↓	↓	↑		↑
FC-43 Heptacosfluorotri-butylamine	↑	↑	↑		↑	↑	↑	↑	↑			↓	↑		
FC75 & FC77 (Fluorocarbon)	↑	↑	↗		↑	↑	↗	↑	↑			↓	↑		
Ferric Acetate	→	↑	→	↓	→	↑	↑	↗	↑	↑	↑	↑	↑	↓	
Ferric Ammonium Sulfate	→	↑	→	↓	→	↑	↑	↗	↑	↑	↑	↑	↑	↓	
Ferric Chloride	↑	↑	↑	↑	↑	↗	↑	↗	↑	↑	↑	↑	↑	↑	↑
Ferric Ferrocyanide	→	↑	→	↓	→	↑	↑	↗	↑	↑	↑	↑	↑	↓	
Ferric Hydroxide	→	↑	→	↓	→	↑	↑	↗	↑	↑	↑	↑	↑	↓	
Ferric Nitrate	↑	↑	↑	↗	↑	↑	↑	↗	↑	↑	↑	↑	↑	↗	

Fluid	NBR	EPDM	FKM	TPU	HNBR	CR	FMQ	MQ	IR	BR	IR	SBR	FFKM	ACM	PTFE
Ferric Persulfate	↑	↑	↑		↑	↑							↑		
Ferric Sulfate	↑	↑	↑		↑	↑							↑		
Ferrous Ammonium Citrate	→	↑	→	↓	→	↑	↑	↗	↑	↑	↑	↑	↑	↓	
Ferrous Ammonium Sulfate	→	↑	→	↓	→	↑	↑	↗	↑	↑	↑	↑	↑	↓	
Ferrous Carbonate	→	↑	→	↓	→	↑	↑	↗	↑	↑	↑	↑	↑	↓	
Ferrous Chloride													↑		
Ferrous Iodide	→	↑	→	↓	→	↑	↑	↗	↑	↑	↑	↑	↑	↓	
Ferrous Sulfate	→	↑	→	↓	→	↑	↑	↗	↑	↑	↑	↑	↑	↓	
Ferrous Tartrate	→	↑	→	↓	→	↑	↑	↗	↑	↑	↑	↑	↑	↓	
Fish Oil	↗	↓	↑	→	↗	↓	↗		↓	↓	↓	↓	↑	↓	↑
Fisher Reagent		↗													
Fluorinated Cyclic Ethers		↑											↑		
Fluorine (Gas)													↗		
Fluorine (Liquid)	↓	↓	↗		↓								↗	↑	
Fluorobenzene	↓	↓	↗		↓	↓	↗		↓	↓	↓	↓	↑	↓	↑
Fluoroboric Acid	↑	↑											↑		
Fluorocarbon Oils		↑											↗	↑	
Fluorolube	↑	↑	↗		↑	↑	↗	↑	↑			↓	↑		
Fluorophosphoric Acid													↑		
Fluorosilicic Acid	↗	↑	↑		↗	↗							↑	↑	
Fluorosulfonic Acid													↑		
Formaldehyde	→	↑	↓	↓	→	↓	↓	↗	↗	↗	↗	↗	↑	↓	↑

# Materials

Fluid	NBR	EPDM	FKM	TPU	HNBR	CR	FMQ	MQ	IIR	BR	IR	SBR	FFKM	ACM	PTFE
Formamide	↗	↗	↘	↗	↘	↗	↗	↗	↗	↗	↗	↗	↘	↘	↗
Formic Acid	↘	↗	↘	↘	↗								↗	↘	↗
Freon, 11	↗	↘	↗	↗	↘	↗	↘	↘				↘	↗	↘	↗
Freon, 112 (Tetrachlorodifluoroethane)	↗	↘	↗	↗	↗	↗	↘	↘				↘	↗		
Freon, 113	↗	↘	↗	↗	↗		↘	↘				↗	→		↗
Freon, 113 + High and Low Aniline Oil	↗												→		
Freon, 114	↗	↗	↗	↗	↗		↘	↗				↗	↗		↗
Freon, 114B2	↗	↘	↗	↗	↗		↘	↘				↘	↗		
Freon, 115, 116	↗	↗	↗	↗	↗			↗				↗	↗		
Freon, 12	↗	↗	↗	↗	↗	↗	→	↘	→	↘	↘	↗	↗		↗
Freon, 12 and ASTM Oil #2 (50/50 Mixture)	↗	↘	↗		↗	→	↗	↘	↘	↘	↘	↘	↗		
Freon, 12 and Suniso 4G (50/50 Mixture)	↗	↘	↗		↗	→	↗	↘	↘	↘	↘	↘	↗		
Freon, 123 (Dichlorotrifluoroethane)													↘		
Freon, 124 (Chlorotetrafluoroethane)													↗		
Freon, 125 (Pentafluoroethane)													↗		
Freon, 13	↗	↗	↗	↗	↗	↗	↘	↘	↗		↗	↗	↗		↗
Freon, 134a (Tetrafluoroethane)		↗			↗								→		↗
Freon, 13B1	↗	↗	↗	↗	↗	↗	↘	↗				↗	↗		
Freon, 14	↗	↗	↗	↗	↗		↘	↗				↗	↗		
Freon, 141b (Dichlorofluoroethane)													↗		
Freon, 142b	↗	↗	↘		↗	↗							→		
Freon, 152a (Difluoroethane)	↗	↗	↘		↗	↗							→		

Fluid	NBR	EPDM	FKM	TPU	HNBR	CR	FMQ	MQ	IIR	BR	IR	SBR	FFKM	ACM	PTFE
Freon, 21	↘	↘	↘	↗	↘	↗		↘	↘	↘	↘	↘	↗	↘	
Freon, 218	↗	↗	↗		↗	↗							↗		
Freon, 22 (Chlorodifluoroethane)	↘	↗	↘	↘	↘	↗	↘	↘	→			↗	↗	↗	↗
Freon, 22 and ASTM Oil #2 (50/50 Mixture)	↘	↘	↗		↘	↗	↗	↘	↘			↘	↗	↗	
Freon, 23 (Fluoroform)													↗		
Freon, 31	↘	↗	↘	↗	↘	↗			↗			↗	↗		
Freon, 32	↗	↗	↘	↗	↗			↗				↗	↗		
Freon, 502	↗	↗	↗		↗	↗			↗			↗	↗		
Freon, BF (R112)	↗	↘	↗	↘	↗	↗		↘	↘			↘	↗		
Freon, C316	↗	↗			↗	↗							↗		
Freon, C318	↗	↗	↗		↗	↗			↗			↗	↗		
Freon, K-142b	↗	↗	↘		↗	↗			↗			↗	↘		
Freon, K-152a	↗	↗	↘		↗	↗			↗			↗	↘		
Freon, MF (R11)	↗	↘	↗	↗	↗	↘		↘	↘			↘	↗		
Freon, PCA (R113)	↗	↘	↗	↗	↗	↗		↘	↘			↗	↗		
Freon, T-P35	↗	↗	↗	↗	↗	↗							↗		
Freon, T-WD602	↗	↗	↗										↗		
Freon, TA	↗	↘	↗	↗	↗	↗							↗		
Freon, TC	↗	↗	↗	↗	↗								↗		
Freon, TF (R113)	↗	↘	↗	↗	↗	↗		↘	↘			↗	↗		
Freon, TMC	↗	↗	↗	↗	↗								↗		
Fuel Oil, #6	↗	↘	↗	↗	↘	↗	↗	↘	↘	↘	↘	↘	↗	↗	↗

Fluid	NBR	EPDM	FKM	TPU	HNBR	CR	FMQ	MQ	IIR	BR	IR	SBR	FFKM	ACM	PTFE
Fuel Oil, 1, and 2	↗	↘	↘	↗	↗	↗	↗	↘	↘	↘	↘	↘	↗	↗	↗
Fuel Oil, Acidic	↗	↘	↗	↗	↗	↗	↗	↘	↘	↘	↘	↘	↗	↗	↗
Fumaric Acid	↗	↗	↗		↗	↗	↗	↘	↗	↗	↗	↗	↗	↘	
Fuming Sulphuric Acid (20/25% Oleum)	↘	↘	↗	↘	↘			↘	↘	↘	↘	↘	↗	↘	
Furaldehyde	↘	↗	↘		↘	↘							↗		
Furan (Furfuran)	↘	↘	↘	↘	↘				↘	↘	↘	↘	↗	↗	↗
Furfural (Furfuraldehyde)	→	↗	↘	→	↘			↘	↗	↘	↘	↘	↗	↘	↗
Furfuraldehyde	↘	↗	↘	→	↘	↘		↘	↗	↘	↘	↘	↗	↘	
Furfuryl Alcohol	↘	↗		↘	↘	↘	↘	↘	↗	↘	↘	↘	↗	↘	↗
Furoic Acid													↗		
Furyl Carbinol	↘	↗		↘	↘	↘	↘	↘	↗	↘	↘	↘		↘	
Fyrquel 150 220 300 550	↘	↗	↗	↘	↘	↘	↗	↗	↗	↘	↘	↘	↗	↘	
Fyrquel 90, 100, 500	↘	↗	↗		↘								↗		
Fyrquel A60	↘	↗	↘		↘	↘							↗		
Gallic Acid	↗	↗	↗	↘	↗	↗	↗		↗		↗	↗	↗	↘	
Gasoline	↗	↘	↘	↗	↗	↗	↗	↘	↘	↘	↘	↘	↗	↘	↗
Gelatin	↗	↗	↗	↘	↗	↗	↗	↗	↗	↗	↗	↗	↗	↗	↗
Germane (Germanium Tetrahydride)													↗		
Girling Brake Fluid	→	↗	↘		→	↗	↘		↗			↗	↗		
Glauber's Salt	↘	↗	↘	↘	↘	↗	↗		↗	↘	↗	↘	↗	↘	
Gluconic Acid	→	↗	→	↘	→	↗	↗	↗	↗	↗	↗	↗	↗	↘	
Glucose	↗	↗	↘	↘	↗	↗	↗	↗	↗	↗	↗	↗	↗	↗	↗

# Materials

Fluid	NBR	EPDM	FKM	TPU	HNBR	CR	FMQ	MQ	IIR	BR	IR	SBR	FFKM	ACM	PTFE
Glue	↑	↑	↑	↑	↑				↑			↑	↑	↑	↑
Glutamic Acid	→	↑	→	↓	→	↑	↑	↑	↑	↑	↑	↑	↑	↓	
Glycerine (Glycerol)	↑	↑	↑	↓	↑	↑	↑	↑	↑	↑	↑	↑	↑	↓	↑
Glycerol Dichlorohydrin	→	↑	→	↓	→	↑	↑	↑	↑	↑	↑	↑	↑	↓	
Glycerol Monochlorohydrin	→	↑	→	↓	→	↑	↑	↑	↑	↑	↑	↑	↑	↓	
Glycerol Triacetate	↑	↑	↓	↓	↑	↑	↑	↑	↑	↑	↑	↑	↑	↓	
Glycerophosphoric Acid	→	↑	→	↓	→	↑	↑	↑	↑	↑	↑	↑	↑	↓	
Glyceryl Phosphate	→	↑	→	↓	→	↑	↑	↑	↑	↑	↑	↑	↑	↓	
Glycidol	→	↑	→	↓	→	↑	↑	↑	↑	↑	↑	↑	↑	↓	
Glycol Monoether													↑		
Glycolic Acid	↑	↑	↑	↓	↑	↑	↑	↑	↑	↑	↑	↑	↑	↓	↑
Glycols	↑	↑	↑	↓	↑	↑	↑	↑	↑	↑	↑	↑	↑	↓	
Glyoxylic Acid	→	↑	→	↓	→	↑	↑	↑	↑	↑	↑	↑	↑	↓	
Grease Petroleum Base	↑	↓	↑	↑	↑	→	↑	↓	↓	↓	↓	↓	↑	↑	
Green Sulfate Liquor	↑	↑	↑	↓	↑	↑	↑		↑	↑	↑	↑	↑	↓	
Gulf Endurance Oils	↑	↓	↑	↑	↑	↑	↑	↓	↓	↓	↓	↓	↑	↑	
Gulf FR Fluids (Emulsion)	↑	↓	↑	↑	↑	↑	↑	↓	↓	↓	↓	↓	↑	↑	
Gulf FR G-Fluids	↑	↑	↑	↑	↑	↑	↑	↑	↑	↑	↑	↑	↑	↓	
Gulf FR P-Fluids	↓	↑	↑	↓	↓	↓	↑	↑	↑	↓	↓	↓	↑	↓	
Gulf Harmony Oils	↑	↓	↑	↑	↑	↑	↑	↓	↓	↓	↓	↓	↑	↑	
Gulf High Temperature Grease	↑	↓	↑	↑	↑	↑	↑	↓	↓	↓	↓	↓	↑	↑	
Gulf Legion Oils	↑	↓	↑	↑	↑	↑	↑	↓	↓	↓	↓	↓	↑	↑	

Fluid	NBR	EPDM	FKM	TPU	HNBR	CR	FMQ	MQ	IIR	BR	IR	SBR	FFKM	ACM	PTFE
Gulf Paramount Oils	↑	↓	↑	↑	↑	↑	↑	↓	↓	↓	↓	↓	↑	↑	
Gulf Security Oils	↑	↓	↑	↑	↑	↑	↑	↓	↓	↓	↓	↓	↑	↑	
Gulfcrown Grease	↑	↓	↑	↑	↑	↑	↑	↓	↓	↓	↓	↓	↑	↑	
Halothane	↓	↓	↑	↓	↓	↑	↓	↓	↓	↓	↓	↓	↑	↓	
Halowax Oil	↓	↓	↑		↓	↓	↑	↓	↓	↓	↓	↓	↑		
Hannifin Lube A	↑	↓	↑	↑	↑	↑	↑	↑	↑	↓	↓	↑	↑	↑	
Heavy Water	↑	↑		↓	↑	↑	↑	↑	↑	↑	↑	↑	↑	↓	
HEF-2 (High Energy Fuel)	↑	↓	↑	↓	↑	↓	↑	↓	↓	↓	↓	↓	↑	↓	
Helium	↑	↑	↑	↑	↑	↑	↑	↑	↑	↑	↑	↑	↑	↑	
Heptachlor	↑	↓	↑	→	↑	↓	↑		↓	↓	↓	↓	↑	↓	
Heptachlorobutene	↑	↓	↑	→	↑	↓	↑		↓	↓	↓	↓	↑	↓	
Heptaldehyde (Heptanal)	↑	↓	↑	↑	↑	↑	↑	↑	↓	↓	↓	↓	↑	↑	
Heptane or n-Heptane	↑	↓	↑	↑	↑	↑	→	↓	↓	↓	↓	↓	↑	↑	
Heptanoic Acid	↑	↓	↑	↑	↑	↑	↑	↑	↓	↓	↓	↓	↑	↑	
Hexachloroacetone	→	↑	→	↓	→	→	↑	↑	↑	↑	↑	↑	↑	↓	
Hexachlorobutadiene	↓	↓	↑	↑	↓	↓	↑		↓	↓	↓	↓	↑	↓	↑
Hexachlorobutene	↑	↓	↑	→	↑	↓	↑		↓	↓	↓	↓	↑	↓	
Hexachloroethane	↑	↓	↑	→	↑	↓	↑		↓	↓	↓	↓	↑	↓	
Hexaethyl Tetraphosphate													↑		
Hexafluoroethane (F-116)													↑		
Hexafluoroxylene													↑		
Hexaldehyde or n-Hexaldehyde	↓	↑	↓	→	↓	↑	↓	↑	↑	↓	↓	↓	↑	↑	

Fluid	NBR	EPDM	FKM	TPU	HNBR	CR	FMQ	MQ	IIR	BR	IR	SBR	FFKM	ACM	PTFE
Hexamethyldisilazane														↑	
Hexamethylene (Cyclohexane)	↑	↓	↑	↑	↑	↑	↑	↑	↓	↓	↓	↓	↑	↑	
Hexamethylene Diammonium Adipate	↑	↓	↑	→	↑	↓	↑		↓	↓	↓	↓	↑	↓	
Hexamethylenediamine	→	↑	→	↓	→	↑	↑	↑	↑	↑	↑	↑	↑	↓	
Hexamethylenetetramine	→	↑	→	↓	→	↑	↑	↑	↑	↑	↑	↑	↑	↓	
Hexane or n-Hexane	↑	↓	↑	↑	↑	↑	→	↓	↓	↓	↓	↓	↑	↑	↑
Hexene-1 or n-Hexene-1	↑	↓	↑	↑	↑	↑	↓	↓	↓	↓	↓	↓	↑	↑	↑
Hexone (Methyl Isobutyl Ketone)	→	↑	→	↓	→	↑	↑	↑	↑	↑	↑	↑	↑	↓	
Hexyl Acetate	↑	↓	↑	↑	↑	↑	↑	↑	↓	↓	↓	↓	↑	↑	
Hexyl Alcohol	↑	↑	↑	↓	↑	↑	↑	↑	→	↑	↑	↑	↑	↓	
Hexylene Glycol	→	↑	→	↓	→	↑	↑	↑	↑	↑	↑	↑	↑	↓	
Hexylresorcinol	↑	↓	↑	→	↑	↓	↑		↓	↓	↓	↓	↑	↓	
High Viscosity Lubricant, H2	↑	↑	↑	↓	↑	↑	↑	↑	↑	↑	↑		↑	↑	↓
High Viscosity Lubricant, U4	↑	↑	↑	↓	↑	↑	↑	↑	↑	↑	↑		↑	↑	↓
HiLo MS #1	↓	↑	↓	↓	↓	↓	→	→	↑	↓	↓	↓	↑	↓	
Houghto-Safe 1010 phosphate ester	↓	↑	↑		↓	↓	↑	→	↑	↓	↓	↓	↑	↓	
Houghto-Safe 1055 phosphate ester	↓	↑	↑		↓	↓	↑	→	↑	↓	↓	↓	↑	↓	
Houghto-Safe 1120 phosphate ester	↓	↑	↑	↓	↓	↓	↑	→	↑	↓	↓	↓	↑	↓	
Houghto-Safe 271 (Water & Glycol Base)	↑	↑	↑	↓	↑	↑	↑	↑					↑	↑	↓
Houghto-Safe 416 & 500 Series	↑	↑			↑										
Houghto-Safe 5040 (Water/Oil emulsion)	↑	↓	↑	↓	↑	↑	↑	→	↓	↓	↓	↓	↑	↓	
Houghto-Safe 620 Water/Glycol	↑	↑	↑	↓	↑	↑	↑	↑					↑	↑	↓

# Materials

Fluid	NBR	EPDM	FKM	TPU	HNBR	CR	FMQ	MQ	IIR	BR	IR	SBR	FFKM	ACM	PTFE
Hydraulic Oil (Petroleum Base, Industrial)	↑	↓	↑	↑	↑	↑	↑	↓	↓	↓	↓	↑	↑		
Hydraulic Oils (Synthetic Base)	↑	↓	↑	→	↑	↓	↑	↓	↓	↓	↓	↑	↓		
Hydrazine	↑	↑	→	↓	↑	↓	↑	↑				↑	↑	→	
Hydrazine (Anhydrous)	↓	↑	↓	↓	↑	↓	↑	↓	↓	↓	↓	↑	↑	↓	
Hydrazine Dihydrochloride	→	↑	→	↓	↑	↑	↑	↑	↑	↑	↑	↑	↑	↓	
Hydrazine Hydrate	→	↑	→	↓	↑	↑	↑	↑	↑	↑	↑	↑	↑	↓	↑
Hydriodic Acid	↑	↓	↑	→	↑	↓	↑	↓	↓	↓	↓	↑	↓		
Hydro-Drive MIH-10 (Petroleum Base)	↑	↓	↑	↑	↑	↑	↑	↓	↓	↓	↓	↑	↑		
Hydro-Drive MIH-50 (Petroleum Base)	↑	↓	↑	↑	↑	↑	↑	↓	↓	↓	↓	↑	↑		
Hydroabietyl Alcohol													↑		
Hydrobromic Acid	↓	↑	↑	↓	↓	↓	→	↓	↑	↓	↑	↓	↑	↓	↑
Hydrobromic Acid 40%	↓	↑	↑	↓	↓	↑	→	↓	↑	↓	↑	↓	↑	↓	
Hydrocarbons, Saturated	↑	↓	↑	↑	↑	↑	↑	↓	↓	↓	↓	↑	↑		
Hydrochloric Acid (cold) 37%	↓	→	↑			↓							↑		
Hydrochloric Acid (hot) 37%	↓	→	↑	→		↓	↑		↓	↓	↓	↓	↑	↓	
Hydrochloric Acid, 3 Molar to 70°C	↑	↑	↑	↓	↑	↑	→	↓	↑			→	↑	→	
Hydrochloric Acid, Concentrated Room Temp.	↑	↑	↑		↑								↑	↑	
Hydrochloric Acid, Concentrated to 70°C	↓	↓	↑	↓	↓	↓	↓	↓	↓			↓	↑	↓	↑
Hydrocyanic Acid	↑	↑	↑		↑	↑	↑	→	↑	↑	↑	↑	↑	↓	↑
Hydrofluoric Acid (Anhydrous)													↑	↑	
Hydrofluoric Acid (conc.) Cold	↓	↑	↑	↓	↓								↑	↓	
Hydrofluoric Acid (conc.) Hot	↓	↓	↓	↓									↑	↓	

Fluid	NBR	EPDM	FKM	TPU	HNBR	CR	FMQ	MQ	IIR	BR	IR	SBR	FFKM	ACM	PTFE
Hydrofluorosilicic Acid	↑	↑	↑		↑	↑	↓	↓	↑		↑	↑			
Hydrogen Bromide (Anhydrous)													↑		
Hydrogen Chloride (Anhydrous)													↑		
Hydrogen Chloride gas	↓	↑	↑			↓	→						↑	↑	
Hydrogen Cyanide													↑		
Hydrogen Fluoride	↓	↑		↓	↓								↑	↓	
Hydrogen Fluoride (Anhydrous)	↓	↑	↓		↓		↓		↑	↓	↓	↓	↑	↓	
Hydrogen Gas, Cold	↑	↑	↑	↑	↑	↑	→	→	↑	↑	↑	↑	↑	↑	↑
Hydrogen Gas, Hot	↑	↑	↑	↑	↑	↑	→	→	↑	↑	↑	↑	↑	↑	↑
Hydrogen Iodide (Anhydrous)													↑		
Hydrogen Peroxide	↑	↑	↑		↑	↑	↑	↑	↑	↑	↑	↑	↑	↓	↑
Hydrogen Peroxide 90%	↓	→	↑		↓	↓	↑	↑	→	↓	↓	↓	↑	↓	↑
Hydrogen Selenide													↑		
Hydrogen Sulfide, Dry, Cold	↑	↑	↓		↑	↑	→	→	↑	↑	↑	↑	↑	↓	↑
Hydrogen Sulfide, Dry, Hot	↓	↑	↓		↓	↑	→	→	↑	↓	↓	↓	↑	↓	↑
Hydrogen Sulfide, Wet, Cold	↓	↑	↓		↓	↑	→	→	↑	↓	↓	↓	↑	↓	↑
Hydrogen Sulfide, Wet, Hot	↓	↑	↓		↓	↑	→	→	↑	↓	↓	↓	↑	↓	↑
Hydrolube-Water/Ethylene Glycol	↑	↑	↑	↓	↑	↑	↑	↑	↑			↑	↑	↓	
Hydroxycitronellal			↑	→		↓	↑		↓	↓	↓	↓	↑	↓	
Hydroquinol	↓	↓	↑		↓	↓							↑		
Hydroquinone	↓	↑	↓		↓	↓	↑		↓	↓	↑	↓	↑	↑	↑
Hydroxyacetic Acid	↓	↑	↓	↓	↓	↓	↑	↑	↑	↑	↑	↑	↑	↓	

Fluid	NBR	EPDM	FKM	TPU	HNBR	CR	FMQ	MQ	IIR	BR	IR	SBR	FFKM	ACM	PTFE
Hydne	↑	↑	↓		↑	↑	↓	↓	↑	↑	↑	↑	↑	↓	
Hyjet	↓	↑	↓		↓	↓							↑		
Hyjet IV and IVA	↓	↑	↓	↓	↓	↓	↓	↓	↑	↓	↓	↓	↑	↓	
Hyjet S4	↓	↑	↓		↓								↑		
Hyjet W	↓	↑	↓		↓	↓							↑		
Hypochlorous Acid	↓	↑	↑		↓	↓			↑	↓	↑	↓	↑	↓	
Indole			↑	→	↓	↑		↓	↓	↓	↓	↓	↑	↓	
Industron FF44	↑	↓	↑	↑	↑	↑	↓	↓	↓	↓	↓	↓	↑	↑	
Industron FF48	↑	↓	↑	↑	↑	↑	↓	↓	↓	↓	↓	↓	↑	↑	
Industron FF53	↑	↓	↑	↑	↑	↑	↓	↓	↓	↓	↓	↓	↑	↑	
Industron FF80	↑	↓	↑	↑	↑	↑	↓	↓	↓	↓	↓	↓	↑	↑	
Insulin	→	↑	→	↓	→	↑	↑	↑	↑	↑	↑	↑	↑	↓	
Iodic Acid	→	↑	→	↓	→	↑	↑	↑	↑	↑	↑	↑	↑	↓	
Iodine	↑	↑	↑		↑	↓	↑		↑		↓	↑	↑	↑	↑
Iodine Pentafluoride	↓	↓	↓	↓	↓	↓	↓	↓	↓	↓	↓	↓	↑	↓	
Iodoform		↑	↑				↑		↓	↓	↓	↓	↑	↑	↑
Isoamyl Acetate	→	↑	→	↓	→	↑	↑	↑	↑	↑	↑	↑	↑	↓	
Isoamyl Butyrate	→	↑	→	↓	→	↑	↑	↑	↑	↑	↑	↑	↑	↓	
Isoamyl Valerate	→	↑	→	↓	→	↑	↑	↑	↑	↑	↑	↑	↑	↓	
Isoboreol			↑	→		↓	↑		↓	↓	↓	↓	↑	↓	
Isobutane	↑	↓	↑	↑	↑	↑	↑	↑	↓	↓	↓	↓	↑	↑	
Isobutyl Acetate	→	↑	→	↓	→	↑	↑	↑	↑	↑	↑	↑	↑	↓	



# Materials

Fluid	NBR	EPDM	FKM	TPU	HNBR	CR	FMQ	MQ	IIR	BR	IR	SBR	FFKM	ACM	PTFE
Isobutyl Alcohol	↗	↗	↗	↘	↗	↗	↗	↗	↗	↗	↗	↗	↗	↘	↗
Isobutyl Chloride	↘	↘	↗		↘	↘							↗		
Isobutyl Ether	↗	↘	↘		↗	→							↗		
Isobutyl Methyl Ketone	↘	↗	↘	↘	↘	↘	↗	↗	↗	↗	↗	↗	↗	↘	
Isobutyl n-Butyrate	↘	↗	↗		↘	↘	↗	↗	↘	↘	↘	↘	↗	↘	
Isobutyl Phosphate	→	↗	→	↘	→	↗	↗	↗	↗	↗	↗	↗	↗	↘	
Isobutylene	↗	↘	↗	↘	↗	↘	↗		↘	↘	↘	↘	↗	↘	
Isobutyraldehyde	↘	↗	↘	↘	↘	↘							↗	↘	
Isobutyric Acid	↗	↗	↘		↗	↘	↗						↗		
Isocrotyl Chloride			↗	→		↘	↗	↘	↘	↘	↘	↘	↗	↘	
Isodecanol	↗	↘	↗	↗	↗	↗	↗	↘	↘	↘	↘	↘	↗	↗	
Isododecane	↗	↘	↗	↘	↗	↗	↗	↘	↘	↘	↘	↘	↗	↘	
Isoeugenol	↗	↘	↗	↗	↗	↗	↗	↘	↘	↘	↘	↘	↗	↗	
Isooctane	↗	↘	↗	↗	↗	↗	↗	↘	↘	↘	↘	↘	↗	↗	↗
Isopentane	↗	↘	↗	↗	↗	↗	↗	↘	↘	↘	↘	↘	↗	↗	
Isophorone (Ketone)	↘	↗	↘	↘	↘	↘	↘	↘	↘	↘	↘	↘	↗	↘	↗
Isopropanol	↗	↗	↗	↘	↗	↗	↗	↗	↗	↗	↗	↗	↗	↘	↗
Isopropyl Acetate	↘	↗	↘	↘	↘	↘	↘	↘	↘	↘	↘	↘	↗	↘	↗
Isopropyl Alcohol	↗	↗	↗	↘	↗	↗	↗	↗	↗	↗	↗	↗	↗	↘	
Isopropyl Chloride	↘	↘	↗	↘	↘	↘	↘	↘	↘	↘	↘	↘	↗	↘	↗
Isopropyl Ether	↘		↘	↘	↘	↘	→	↘	↘	↘	↘	↘	↗	↘	↗
Isopropylacetone	→	↗	→	↘	→	↗	↗	↗	↗	↗	↗	↗	↗	↘	

Fluid	NBR	EPDM	FKM	TPU	HNBR	CR	FMQ	MQ	IIR	BR	IR	SBR	FFKM	ACM	PTFE
Isopropylamine	→	↗	→	↘	→	↗	↗	↗	↗	↗	↗	↗	↗	↘	
Jet Fuel A	↗	↘	↗	→	↗	↘	↗		↘	↘	↘	↘	↗	↘	
JP-10	→	↘	↗	→	→	↘	↗	↘				↘	↗	↘	
JP-3 (MIL-J-5624)	↗	↘	↗		↗	↘							↗		↗
JP-4 (MIL-T-5624)	↗	↘	↗	↗	↗	↘	↗	↘	↘	↘	↘	↘	↗	↗	↗
JP-5 (MIL-T-5624)	↗	↘	↗	↗	↗	↘	↗	↘	↘	↘	↘	↘	↗	↗	↗
JP-6 (MIL-J-25656)	↗	↘	↗	↗	↗	↘	↗	↘	↘	↘	↘	↘	↗	↗	↗
JP-8 (MIL-T-83133)	↗	↘	↗	↗	↗	→	↗	↘	↘			↘	↗	↗	
JP-9 -11	↘	↘	↗	↘	↘	↘	↗	↘	↘			↘	↗	↘	
JP-9 (MIL-F-81912)	→	↘	↗	→	→	↘	↗	↘	↘			↘	↗	↘	
JPX (MIL-F-25604)	↗	↘	↘		↗	↗							↗		
Kel F Liquids	↗	↗	↗		↗	↗	↗	↗				↗	↗		
Kerosene (Similar to RP-1 and JP-1)	↗	↘	↗	↗	↗	↘	↗	↘	↘	↘	↘	↘	↗	→	↗
Keystone #87HX-Grease	↗	↘	↗	↗	↗	↘	↗	↘	↘	↘	↘	↘	↗	↗	
Lacquer Solvents	↘	↘	↘	↘	↘	↘	↘	↘	↘	↘	↘	↘	↗	↘	
Lacquers	↘	↘	↘	↘	↘	↘	↘	↘	↘	↘	↘	↘	↗	↘	
Lactams-Amino Acids	↘	↗	↘		↘	↗	↘		↗	↘	↘	↘	↗		
Lactic Acid, Cold	↗	↗	↗		↗	↗	↗	↗	↗	↗	↗	↗	↗	↘	↗
Lactic Acid, Hot	↘	↘	↗		↘	↘	↗	↗	↘	↘	↘	↘	↗	↘	↗
Lactones (Cyclic Esters)	↘	↗	↘	↘	↘	↘	↘	↗	↗	↘	↘	↘	↗	↘	
Lard Animal Fat	↗	↗	↗	↗	↗	↗	↗	↗	↗	↘	↘	↘	↗	↗	
Lauric Acid	↗	↘	↗	↗	↗	↗	↗	↗	↘	↘	↘	↘	↗	↗	

Fluid	NBR	EPDM	FKM	TPU	HNBR	CR	FMQ	MQ	IIR	BR	IR	SBR	FFKM	ACM	PTFE
Lavender Oil	↗	↘	↗	↘	↗	↘							↗	↗	↗
LB 135	↗	↗	↗		↗	↗							↗		
Lead (Molten)													↗		
Lead Acetate	↗	↗	↘	↘	↗	↗	↘	↘	↗	↗	↗	↘	↗	↘	↗
Lead Arsenate	↗	↗		↗	↗		↗	↗	↗	↗	↗	↗	↗		
Lead Azide													↗		
Lead Bromide	→	↗	→	↘	→	↗	↗	↗	↗	↗	↗	↗	↗	↘	
Lead Carbonate	→	↗	→	↘	→	↗	↗	↗	↗	↗	↗	↗	↗	↘	
Lead Chloride	→	↗	→	↘	→	↗	↗	↗	↗	↗	↗	↗	↗	↘	
Lead Chromate	→	↗	→	↘	→	↗	↗	↗	↗	↗	↗	↗	↗	↘	
Lead Dioxide	→	↗	→	↘	→	↗	↗	↗	↗	↗	↗	↗	↗	↘	
Lead Linoleate	→	↗	→	↘	→	↗	↗	↗	↗	↗	↗	↗	↗	↘	
Lead Naphthenate													↗		
Lead Nitrate	↗	↗	↗	↘	↗	↗	↗	↗	↗	↗	↗	↗	↗	↗	↗
Lead Oxide	→	↗	→	↘	→	↗	↗	↗	↗	↗	↗	↗	↗	↘	
Lead Sulfamate	↗	↗	↗		↗	↗	↗	↗	↗	↗	↗	↗	↗	↘	
Lehigh X1169	↗	↘	↗	↗	↗	↗	↗	↘	↘	↘	↘	↘	↗	↗	
Lehigh X1170	↗	↘	↗	↗	↗	↗	↗	↘	↘	↘	↘	↘	↗	↗	
Light Grease	↗	↘	↗		↗	↘							↗		
Ligroin (Petroleum Ether or Benzene)	↗	↘	↗	↗	↗	↗	↗	↘	↘	↘	↘	↘	↗	↗	
Lime Bleach	↗	↗	↗		↗	↗							↗		
Lime Sulfur			↗	→	↘	↗	↘	↘	↘	↘	↘	↘	↗	↘	

# Materials

Fluid	NBR	EPDM	FKM	TPU	HNBR	CR	FMQ	MQ	IIR	BR	IR	SBR	FFKM	ACM	PTFE
Lindol, Hydraulic Fluid (Phosphate ester type)	↓	↑	↔	↔	↓	↓	↔	↔	↑	↓	↓	↓	↑	↓	
Linoleic Acid	↔	↓	↔	↔	↔		↔	↓	↓	↓	↓	↓	↑		↑
Linseed Oil	↑	↔	↑	↑	↑	↑	↑	↔	↓	↓	↓	↓	↑	↔	↑
Liquid Oxygen (LOX)	↓	↓	↓	↓	↓	↓	↓	↓	↓	↓	↓	↓	↔	↓	
Liquid Petroleum Gas (LPG)	↑	↓	↑	↑	↑	↔	↔	↓	↓	↓	↓	↓	↑	↔	
Liquimoly	↑	↓	↑	↔	↑	↔	↑	↓	↓	↓	↓	↓	↑	↑	
Lithium Bromide (Brine)	↑	↑	↑	↓	↑	↑	↑	↔	↑	↑	↑	↑	↑	↓	↑
Lithium Carbonate	↔	↑	↔	↓	↔	↑	↑	↔	↑	↑	↑	↑	↑	↓	
Lithium Chloride	↑	↑	↑	↓	↑	↑	↑	↔	↑	↑	↑	↑	↑	↓	↑
Lithium Citrate	↔	↑	↔	↓	↔	↑	↑	↔	↑	↑	↑	↑	↑	↓	
Lithium Hydroxide	↓	↑	↔	↓	↓	↓	↑	↔	↑	↑	↑	↑	↑	↓	
Lithium Hypochlorite	↔	↑	↔	↓	↔	↑	↑	↔	↑	↑	↑	↑	↑	↓	
Lithium Nitrate	↔	↑	↔	↓	↔	↑	↑	↔	↑	↑	↑	↑	↑	↓	
Lithium Nitrite	↔	↑	↔	↓	↔	↑	↑	↔	↑	↑	↑	↑	↑	↓	
Lithium Perchlorate	↔	↑	↔	↓	↔	↑	↑	↔	↑	↑	↑	↑	↑	↓	
Lithium Salicylate	↔	↑	↔	↓	↔	↑	↑	↔	↑	↑	↑	↑	↑	↓	
Lithopone	↔	↑	↔	↓	↔	↑	↑	↔	↑	↑	↑	↑	↑	↓	
Lubricating Oils (Crude & Refined)	↔	↓	↑	↔	↔								↑		
Lubricating Oils (Synthetic base)			↑	↔	↓	↔			↓	↓	↓	↓	↑	↓	
Lubricating Oils, Di-ester	↔	↓	↑	↔	↔	↔	↓	↓	↓	↓	↓	↓	↑	↔	
Lubricating Oils, petroleum base	↑	↓	↑	↔	↔	↑	↓	↓	↓	↓	↓	↓	↑	↑	
Lubricating Oils, SAE 10, 20, 30, 40, 50	↑	↓	↑	↔	↔	↑	↓	↓	↓	↓	↓	↓	↑	↑	

Fluid	NBR	EPDM	FKM	TPU	HNBR	CR	FMQ	MQ	IIR	BR	IR	SBR	FFKM	ACM	PTFE
Lye Solutions	↔	↑	↑	↓	↔	↔	↔	↔	↑	↔	↔	↔	↑	↓	
Magnesium Chloride	↑	↑	↑	↑	↑	↑	↑	↑	↑	↑	↑	↑	↑	↑	↑
Magnesium Hydroxide	↔	↑	↑	↓	↔	↔			↑	↔	↔	↔	↑	↓	
Magnesium Salts	↑	↑	↑	↑	↑	↑	↑	↑	↑	↑	↑	↑	↑	↑	
Magnesium Sulfite and Sulfate	↑	↑	↑		↑	↑	↑	↑	↑	↔	↔	↔	↑	↓	↑
Magnesium Trisilicate													↑		
Malathion	↔	↓	↑		↔	↔	↓	↓	↓	↓	↓	↓	↑		
Maleic Acid	↔	↑	↑	↔	↔	↔			↓	↓	↓	↓	↑	↔	↑
Maleic Anhydride	↓	↓	↔		↓	↓			↔	↓	↓	↓	↑	↓	↑
Maleic Hydrazide	↔	↑	↔	↓	↔	↑	↑	↔	↑	↑	↑	↑	↑	↓	
Malic Acid	↑	↔	↑	↓	↑	↔	↑	↔	↓	↔	↔	↔	↑	↓	
Mandelic Acid	↔	↑	↔	↓	↔	↑	↑	↔	↑	↑	↑	↑	↑	↓	
Manganese Acetate	↔	↑	↔	↓	↔	↑	↑	↔	↑	↑	↑	↑	↑	↓	
Manganese Carbonate	↔	↑	↔	↓	↔	↑	↑	↔	↑	↑	↑	↑	↑	↓	
Manganese Chloride	↔	↑	↔	↓	↔	↑	↑	↔	↑	↑	↑	↑	↑	↓	
Manganese Dioxide	↔	↑	↔	↓	↔	↑	↑	↔	↑	↑	↑	↑	↑	↓	
Manganese Gluconate	↔	↑	↔	↓	↔	↑	↑	↔	↑	↑	↑	↑	↑	↓	
Manganese Hypophosphite	↔	↑	↔	↓	↔	↑	↑	↔	↑	↑	↑	↑	↑	↓	
Manganese Linoleate	↔	↑	↔	↓	↔	↑	↑	↔	↑	↑	↑	↑	↑	↓	
Manganese Naphthenate													↑		
Manganese Phosphate	↔	↑	↔	↓	↔	↑	↑	↔	↑	↑	↑	↑	↑	↓	
Manganese Sulfate	↔	↑	↔	↓	↔	↑	↑	↔	↑	↑	↑	↑	↑	↓	

Fluid	NBR	EPDM	FKM	TPU	HNBR	CR	FMQ	MQ	IIR	BR	IR	SBR	FFKM	ACM	PTFE
Manganous Chloride	↔	↑	↔	↓	↔	↑	↑	↔	↑	↑	↑	↑	↑	↓	
Manganous Sulfate	↔	↑	↔	↓	↔	↑	↑	↔	↑	↑	↑	↑	↑	↓	
Mannitol	↔	↑	↔	↓	↔	↑	↑	↔	↑	↑	↑	↑	↑	↓	
MCS 312	↓	↓	↑		↓	↓	↑	↑	↓	↓	↓	↓	↑	↓	
MCS 352	↓	↑	↓	↓	↓	↓	↔	↔	↔	↓	↓	↓	↑	↓	
MCS 463	↓	↑	↓	↓	↓	↓	↔	↔	↔	↓	↓	↓	↑	↓	
MDI (Methylene di-phenylene isocyanate)	↔	↑	↔	↓	↔	↑	↑	↔	↑	↑	↑	↑	↑	↓	
Mercaptan	↓	↑	↓	↓	↓	↓	↑	↔	↓	↓	↓	↓	↑	↓	
Mercaptobenzothiazole (MBT)		↑	↔		↓	↔			↓	↓	↓	↓	↑	↓	
Mercuric Acetate	↔	↑	↔	↓	↔	↑	↑	↔	↑	↑	↑	↑	↑	↓	
Mercuric Chloride	↑	↑	↑		↑	↑			↑	↑	↑	↑	↑		
Mercuric Cyanide	↔	↑	↔	↓	↔	↑	↑	↔	↑	↑	↑	↑	↑	↓	
Mercuric Iodide	↔	↑	↔	↓	↔	↑	↑	↔	↑	↑	↑	↑	↑	↓	
Mercuric Nitrate	↔	↑	↔	↓	↔	↑	↑	↔	↑	↑	↑	↑	↑	↓	
Mercuric Sulfate	↔	↑	↔	↓	↔	↑	↑	↔	↑	↑	↑	↑	↑	↓	
Mercuric Sulfite	↔	↑	↔	↓	↔	↑	↑	↔	↑	↑	↑	↑	↑	↓	
Mercurous Nitrate	↔	↑	↔	↓	↔	↑	↑	↔	↑	↑	↑	↑	↑	↓	
Mercury	↑	↑	↑	↑	↑				↑	↑	↑	↑	↑	↑	↑
Mercury Chloride	↔	↑	↔	↓	↔	↑	↑	↔	↑	↑	↑	↑	↑	↓	
Mercury Fulminate	↔	↑	↔	↓	↔	↑	↑	↔	↑	↑	↑	↑	↑	↓	
Mercury Salts	↔	↑	↔	↓	↔	↑	↑	↔	↑	↑	↑	↑	↑	↓	↑
Mercury Vapors	↑	↑	↑		↑	↑			↑	↑	↑	↑	↑		

# Materials

Fluid	NBR	EPDM	FKM	TPU	HNBR	CR	FMQ	MQ	IIR	BR	IR	SBR	FFKM	ACM	PTFE
Mesityl Oxide (Ketone)	↓	↑	↓	↓	↓	↓	↓	↓	↓	↓	↓	↓	↑	↓	↑
Meta-Cresol			↑	→	↓	↓	↓	↓	↓	↓	↓	↓	↑	↓	
Meta-Nitroaniline	→	↑	→	↓	→	↑	↑	↓	↑	↑	↑	↑	↑	↓	
Meta-Toluidine			↑	→	↓	↓	↓	↓	↓	↓	↓	↓	↑	↓	
Metaldehyde	→	↑	→	↓	→	↑	↑	↓	↑	↑	↑	↑	↑	↓	
Methacrylic Acid	↓	↓	↓	↓	↓	↓	↓	↓	↓	↓	↓	↓	↓	↓	
Methallyl Chloride			↑	→	↓	↓	↓	↓	↓	↓	↓	↓	↑	↓	
Methane	↑	↓	↑	↓	↑	↓	↓	↓	↓	↓	↓	↓	↑	↓	↑
Methanol	↓	↑	↓	↓	↓	↓	↓	↓	↓	↓	↓	↓	↓	↓	↑
Methoxychlor													↑		
Methoxyethanol (DGMEA)	→	↑	→	↓	→	↑	↑	↓	↑	↑	↑	↑	↑	↓	
Methyl Abietate			↑	→	↓	↓	↓	↓	↓	↓	↓	↓	↑	↓	
Methyl Acetate	↓	↓	↓	↓	↓	↓	↓	↓	↓	↓	↓	↓	↑	↓	
Methyl Acetoacetate	↓	↓	↓	↓	↓	↓	↓	↓	↓	↓	↓	↓	↑	↓	
Methyl Acetophenone *			↑	→	↓	↓	↓	↓	↓	↓	↓	↓	↑	↓	
Methyl Acrylate	↓	↓	↓	↓	↓	↓	↓	↓	↓	↓	↓	↓	↑	↓	↑
Methyl Alcohol	↓	↑	↓	↓	↓	↓	↓	↓	↓	↓	↓	↓	↑	↓	
Methyl Amylketone	→	↑	→	↓	→	↑	↑	↓	↑	↑	↑	↑	↑	↓	
Methyl Anthranilate			↑	→	↓	↓	↓	↓	↓	↓	↓	↓	↑	↓	
Methyl Benzoate	↓	↓	↑	↓	↓	↓	↓	↓	↓	↓	↓	↓	↑	↓	
Methyl Bromide	↓	↓	↑	↓	↓	↓	↓	↓	↓	↓	↓	↓	↑	↓	↑
Methyl Butyl Ketone	↓	↑	↓	↓	↓	↓	↓	↓	↓	↓	↓	↓	↑	↓	

Fluid	NBR	EPDM	FKM	TPU	HNBR	CR	FMQ	MQ	IIR	BR	IR	SBR	FFKM	ACM	PTFE
Methyl Butyrate Cellosolve	→	↑	→	↓	→	↑	↑	↓	↑	↑	↑	↑	↑	↓	
Methyl Butyrate Chloride	→	↑	→	↓	→	↑	↑	↓	↑	↑	↑	↑	↑	↓	
Methyl Carbonate	↓	↓	↓	↓	↓	↓	↓	↓	↓	↓	↓	↓	↑	↓	
Methyl Cellosolve	↓	↓	↓	↓	↓	↓	↓	↓	↓	↓	↓	↓	↑	↓	
Methyl Cellulose	↓	↓	↓	↓	↓	↓	↓	↓	↓	↓	↓	↓	↑	↓	
Methyl Chloride	↓	↓	↓	↓	↓	↓	↓	↓	↓	↓	↓	↓	↑	↓	↑
Methyl Chloroacetate	→	↑	→	↓	→	↑	↑	↓	↑	↑	↑	↑	↑	↓	
Methyl Chloroform	↓	↓	↑		↓	↓							↑		
Methyl Chloroformate	↓	↓	↑	↓	↓	↓	↓	↓	↓	↓	↓	↓	↑	↓	
Methyl Chlorosilanes													↑		
Methyl Cyanide (Acetonitrile)	→	↑	→	↓	→	↑	↑	↓	↑	↑	↑	↑	↑	↓	
Methyl Cyclohexanone	↑	↓	↑	↑	↑	↓	↓	↓	↓	↓	↓	↓	↑	↑	
Methyl Dichloride			↑	→	↓	↓	↓	↓	↓	↓	↓	↓	↑	↓	
Methyl Ether	↑	↓	↑		↑	→	↑	↑	↓	↑	↑	↓	↑	↓	
Methyl Ethyl Ketone (MEK)	↓	↓	↓	↓	↓	↓	↓	↓	↓	↓	↓	↓	↑	↓	↑
Methyl Ethyl Ketone Peroxide	↓	↓	↓	↓	↓	↓	↓	↓	↓	↓	↓	↓	↑	↓	
Methyl Ethyl Oleate			↑	→	↓	↓	↓	↓	↓	↓	↓	↓	↑	↓	
Methyl Formate	↓	↓	↓		↓	↓		↓	↓	↓	↓	↓	↑	↓	
Methyl Hexyl Ketone (2-Octanone)	→	↑	→	↓	→	↑	↑	↓	↑	↑	↑	↑	↑	↓	
Methyl Iodide	↑	↓	↑	↑	↑	↓	↓	↓	↓	↓	↓	↓	↑	↑	
Methyl Isobutyl Ketone (MIBK)	↓	→	↓	↓	↓	↓	↓	↓	↓	↓	↓	↓	↑	↓	↑
Methyl Isocyanate	→	↑	→	↓	→	↑	↑	↓	↑	↑	↑	↑	↑	↓	

Fluid	NBR	EPDM	FKM	TPU	HNBR	CR	FMQ	MQ	IIR	BR	IR	SBR	FFKM	ACM	PTFE
Methyl Isopropyl Ketone	↓	↓	↓	↓	↓	↓	↓	↓	↓	↓	↓	↓	↑	↓	
Methyl Isovalerate			↑	→	↓	↓	↓	↓	↓	↓	↓	↓	↑	↓	
Methyl Lactate	→	↑	→	↓	→	↑	↑	↓	↑	↑	↑	↑	↑	↓	
Methyl Mercaptan		↑						↑					↑		
Methyl Methacrylate	↓	↓	↓	↓	↓	↓	↓	↓	↓	↓	↓	↓	↑	↓	↑
Methyl Oleate	↓	↓	↑		↓	↓	↓	↓	↓	↓	↓	↓	↑	↓	
Methyl Pentadiene			↑	→	↓	↓	↓	↓	↓	↓	↓	↓	↑	↓	
Methyl Phenylacetate			↑	→	↓	↓	↓	↓	↓	↓	↓	↓	↑	↓	
Methyl Salicylate	↓	↓			↓	↓			↓				→	↑	
Methyl Tertiary Butyl Ether (MTBE)	→	→	→		→	→							↑		
Methyl Valerate			↑	→	↓	↓	↓	↓	↓	↓	↓	↓	↑	↓	
Methyl-2-Pyrrolidone or n-Methyl-2-Pyrrolidone	↓												↑		
Methylacrylic Acid	↓	↓	↓	↓	↓	↓	↓	↓	↓	↓	↓	↓	↑	↓	
Methylal													↑		
Methylamine	→	↑	→	↓	→	↑	↑	↓	↑	↑	↑	↑	↑	↓	
Methylamyl Acetate	→	↑	→	↓	→	↑	↑	↓	↑	↑	↑	↑	↑	↓	
Methylcyclopentane	↓	↓	↑	↓	↓	↓	↓	↓	↓	↓	↓	↓	↑	↓	
Methylene Bromide			↑	→	↓	↓	↓	↓	↓	↓	↓	↓	↑	↓	
Methylene Chloride	↓	↓	↓	↓	↓	↓	↓	↓	↓	↓	↓	↓	↑	↓	
Methylene Iodide			↑	→	↓	↓	↓	↓	↓	↓	↓	↓	↑	↓	
Methylglycerol	→	↑	→	↓	→	↑	↑	↓	↑	↑	↑	↑	↑	↓	
Methylisobutyl Carbinol	↑	↓	↑	↑	↑	↓	↓	↓	↓	↓	↓	↓	↑	↓	

# Materials

Fluid	NBR	EPDM	FKM	TPU	HNBR	CR	FMQ	MQ	IIR	BR	IR	SBR	FFKM	ACM	PTFE
Methylpyrrolidine			→	→		↓	→		↓	↓	↓	↓	↑	↓	
Methylpyrrolidone			→	→		↓	→		↓	↓	↓	↓	↑	↓	
Methylsulfuric Acid	→	→	→	→	→	→	→	→	→	→	→	→	→	→	↓
MIL-A-6091	→	→	→	→	→	→	→	→	→	→	→	→	→	→	↓
MIL-C-4339	→	↓	→	→	→	↓	→	→	↓	↓	↓	↓	↑	→	
MIL-C-7024	→	↓	→	→	→	→	→	↓	↓	↓	↓	↓	↑	→	
MIL-C-8188	→	↓	→	→	→	↓	→	↓	↓	↓	↓	↓	↑	→	
MIL-E-9500	→	→	→	→	→	→	→	→	→	→	→	→	→	→	↓
MIL-F-16884	→	↓	→	→	→	→	→	↓	↓	↓	↓	↓	↑	→	
MIL-F-17111	→	↓	→	→	→	→	→	↓	↓	↓	↓	↓	↑	→	
MIL-F-25558 (RJ-1)	→	↓	→	→	→	→	→	↓	↓	↓	↓	↓	↑	→	
MIL-F-25656	→	↓	→	→	→	→	→	↓	↓	↓	↓	↓	↑	→	
MIL-F-5566	→	→	→	→	→	→	→	→	→	→	→	→	→	→	↓
MIL-F-81912 (JP-9)	→	↓	→	→	→	↓	→	↓				↓	↑	↓	
MIL-F-82522 (RJ-4)	→	↓	→	→	→	→	→	↓	↓	↓	↓	↓	↑	→	
MIL-G-10924	→	↓	→	→	→	→	→	↓	↓	↓	↓	↓	↑	→	
MIL-G-15793	→	↓	→	→	→	→	→	↓	↓	↓	↓	↓	↑	→	
MIL-G-21568	→	→	→	→	→	→	→	↓	↓	↓	↓	↓	↑	→	
MIL-G-25013	→	→	→	→	→	→	→	↓	↓	↓	↓	↓	↑	→	
MIL-G-25537	→	↓	→	→	→	→	→	↓	↓	↓	↓	↓	↑	→	
MIL-G-25760	→	↓	→	→	→	→	→	↓	↓	↓	↓	↓	↑	→	
MIL-G-3278	→	↓	→	→	→	→	→	↓	↓	↓	↓	↓	↑	→	

Fluid	NBR	EPDM	FKM	TPU	HNBR	CR	FMQ	MQ	IIR	BR	IR	SBR	FFKM	ACM	PTFE
MIL-G-3545	→	↓	→	→	→	→	→	↓	↓	↓	↓	↓	↑	→	
MIL-G-4343	→	→	→	→	→	→	→	→	→	→	→	→	→	→	
MIL-G-5572	→	↓	→	→	→	→	→	↓	↓	↓	↓	↓	↑	→	
MIL-G-7118	→	↓	→	→	→	→	→	↓	↓	↓	↓	↓	↑	→	
MIL-G-7187	→	↓	→	→	→	→	→	↓	↓	↓	↓	↓	↑	→	
MIL-G-7421	→	↓	→	→	→	→	→	↓	↓	↓	↓	↓	↑	→	
MIL-G-7711	→	↓	→	→	→	→	→	↓	↓	↓	↓	↓	↑	→	
MIL-H-13910	→	→	→	→	→	→	→	↓	↓	↓	↓	↓	↑	→	
MIL-H-19457	→	→	→	→	→	→	→	↓	↓	↓	↓	↓	↑	→	
MIL-H-22251	→	→			→	→		↓	↓			→			
MIL-H-27601	→	↓	→	→	→	→	→	↓	↓	↓	↓	↓	↑	→	
MIL-H-46170 -25 to +200 °C	→	↓	→	→	→	→	→	↓	↓	↓	↓	↓	↑	→	
MIL-H-46170 -30 to +135 °C	→	↓	→	→	→	→	→	↓	↓	↓	↓	↓	↑	→	
MIL-H-46170 -50 to +135 °C	→	↓	→	→	→	→	→	↓	↓	↓	↓	↓	↑	→	
MIL-H-46170 -55 to +135 °C	→	↓	→	→	→	→	→	↓	↓	↓	↓	↓	↑	→	
MIL-H-5606 -54 to +113 °C	→	↓	→	→	→	→	→	↓	↓	↓	↓	↓	↑	→	
MIL-H-5606 -54 to +135 °C	→	↓	→	→	→	→	→	↓	↓	↓	↓	↓	↑	→	
MIL-H-6083	→	↓	→	→	→	→	→	↓	↓	↓	↓	↓	↑	→	
MIL-H-7083	→	→	→	→	→	→	→	↓	↓	↓	↓	↓	↑	→	
MIL-H-8446 (MLO-8515)	→	↓	→	→	→	→	→	↓	↓	↓	↓	↓	↑	→	
MIL-J-5161	→	↓	→	→	→	→	→	↓	↓	↓	↓	↓	↑	→	
MIL-L-15016	→	↓	→	→	→	→	→	↓	↓	↓	↓	↓	↑	→	

Fluid	NBR	EPDM	FKM	TPU	HNBR	CR	FMQ	MQ	IIR	BR	IR	SBR	FFKM	ACM	PTFE
MIL-L-15017	→	↓	→	→	→	→	→	↓	↓	↓	↓	↓	↑	→	
MIL-L-17331	→	↓	→	→	→			↓	↓	↓	↓	↓	↑		
MIL-L-2104	→	↓	→	→	→	→	→	↓	↓	↓	↓	↓	↑	→	
MIL-L-21260	→	↓	→	→	→	→	→	↓	↓	↓	↓	↓	↑	→	
MIL-L-23699	→	↓	→	→	→	→	→	↓	↓	↓	↓	↓	↑	→	
MIL-L-25681	→	→	→	→	→	→	→	↓	↓	↓	↓	↓	↑	→	
MIL-L-3150	→	↓	→	→	→	→	→	↓	↓	↓	↓	↓	↑	→	
MIL-L-6081	→	↓	→	→	→	→	→	↓	↓	↓	↓	↓	↑	→	
MIL-L-6082	→	↓	→	→	→	→	→	↓	↓	↓	↓	↓	↑	→	
MIL-L-6085	→	↓	→	→	→	→	→	↓	↓	↓	↓	↓	↑	→	
MIL-L-6387	→	↓	→	→	→	→	→	↓	↓	↓	↓	↓	↑	→	
MIL-L-7808	→	↓	→	→	→	→	→	↓	↓	↓	↓	↓	↑	→	
MIL-L-7870	→	↓	→	→	→	→	→	↓	↓	↓	↓	↓	↑	→	
MIL-L-9000	→	↓	→	→	→	→	→	↓	↓	↓	↓	↓	↑	→	
MIL-L-9236	→	↓	→	→	→	→	→	↓	↓	↓	↓	↓	↑	→	
MIL-O-3503	→	↓	→	→	→	→	→	↓	↓	↓	↓	↓	↑	→	
MIL-P-27402	→	→			→	→		↓	↓			→			
MIL-R-25576 (RP-1)	→	↓	→	→	→	→	→	↓	↓	↓	↓	↓	↑	→	
MIL-S-3136, Type I Fuel	→	↓	→	→	→	→	→	↓	↓	↓	↓	↓	↑	→	
MIL-S-3136, Type II Fuel	→	↓	→	→	→	→	→	↓	↓	↓	↓	↓	↑	→	
MIL-S-3136, Type III Fuel	→	↓	→	→	→	→	→	↓	↓	↓	↓	↓	↑	→	
MIL-S-3136, Type IV Oil High Swell	→	↓	→	→	→	→	→	↓	↓	↓	↓	↓	↑	→	

# Materials

Fluid	NBR	EPDM	FKM	TPU	HNBR	CR	FMQ	MQ	IIR	BR	IR	SBR	FFKM	ACM	PTFE
MIL-S-3136, Type IV Oil Low Swell	↑	↓	↑	↑	↑	↑	→	↓	↓	↓	↓	↓	↑	↑	
MIL-S-3136, Type V Oil Medium Swell	↑	↓	↑	↑	↑	↑	↑	↓	↓	↓	↓	↓	↑	↑	
MIL-S-81087	↑	↑	↑	↑	↑	↑	↑	↑	↑	↑	↑	↑	↑	↑	
MIL-T-5624, JP-4, JP-5	↑	↓	↑	↑	↑	↑	↓	↓	↓	↓	↓	↓	↑	↑	
MIL-T-83133	↑	↓	↑	↑	↑	↑	↓	↓				↓	↑	↑	
Milk	↑	↑	↑	↑	↑	↑	↑	↑	↑	↑	↑	↑	↓	↑	
Mineral Oils	↑	↓	↑	↑	↑	↑	↑	↓	↓	↓	↓	↓	↑	↑	
Mixed Acids	→	↑	→	↓	→	↑	↑	↑	↑	↑	↑	↑	↓	↑	
MLO-7277 Hydr.	→	↓	↑	→	→	↓	↓	↓	↓	↓	↓	↓	↑	→	
MLO-7557	→	↓	↑	→	→	↓	↓	↓	↓	↓	↓	↓	↑	→	
MLO-8200 Hydr.	↑	↓	↑	↑	↑	↑	↓	↓	↓	↓	↓	↓	↑		
MLO-8515	↑	↓	↑	↑	↑	↑	↓	↓	↓	↓	↓	↓	↑	→	
Mobil 24dte	↑	↓	↑		↑	↑							↑		
Mobil 254 Lubricant													↑		
Mobil Delvac 1100, 1110, 1120, 1130	↑	↓	↑		↑	↑							↑		
Mobil HF	↑	↓	↑		↑	↑							↑		
Mobil Nivac 20, 30	↑	↑	↑		↑	↑							↑		
Mobil SHC 500 Series	→	↓	↑	↑	→	↑	↑	↑	↓				↑	↑	
Mobil SHC 600 Series	→	↓	↑	↑	→	↑	↑	→	↓			↓	↑	↑	
Mobil Therm 600	↑	↓	↑		↑	↑							↑		
Mobil Velocite c	↑	↓	↑		↑	↑							↑		
Mobilgas WA200 ATF	↑	↓	↑		↑	↑							↑		

Fluid	NBR	EPDM	FKM	TPU	HNBR	CR	FMQ	MQ	IIR	BR	IR	SBR	FFKM	ACM	PTFE
Mobilgear 600 Series	→	→	↑	↑	→	↑	↑	↑	→	→	↓	↓	↑	↑	
Mobilgear SHC ISO Series	→	→	↑	↑	→	↑	↑	→	→	→	↓	↓	↑	↑	
Mobilgrease HP	↑	↓	↑	↑	↑	↑	↑	↓			↓	↓	↑	↑	
Mobilgrease HTS	↑	↓	↑	↑	↑	↑	↑	↓			↓	↓	↑	↑	
Mobilgrease SM	↑	↓	↑	↑	↑	↑	↑	↓			↓	↓	↑	↑	
Mobilith AW Series	↑	↓	↑	↑	↑	↑	↑	↓			↓	↓	↑	↑	
Mobilith SHC Series	↑	↓	↑	↑	↑	↑	↑	↓			↓	↓	↑	↑	
Mobiljet II Lubricant													↑		
Mobilmistlube Series	→	→	↑	↑	→	↑	↑	↑	→	→	↓	↓	↑	↑	
Mobiloil SAE 20	↑	↓	↑		↑	↑							↑		
Mobilux	↑	↓	↑		↑	↑							↑		
Molybdenum Disulfide Grease	↑	↓	↑			↓							↑		
Molybdenum Oxide	→	↑	→	↓	→	↑	↑	↑	↑	↑	↑	↑	↑	↓	
Molybdenum Trioxide	→	↑	→	↓	→	↑	↑	↑	↑	↑	↑	↑	↑	↓	
Molybdic Acid	→	↑	→	↓	→	↑	↑	↑	↑	↑	↑	↑	↑	↓	
Monobromobenzene	↓	↓	↑	↓	↓	↓	↑	↓	↓	↓	↓	↓	↑	↓	↑
Monobromotoluene			↑	→		↓	↑		↓	↓	↓	↓	↑	↓	
Monobutyl Paracresol													↑		
Monochloroacetic Acid	↓	↑	↓	↓	↓	↑	↑	↑	↑	↑	↑	↑	↑	↓	↑
Monochlorobenzene	↓	↓	↑	↓	↓	↓	↑	↓	↓	↓	↓	↓	↑	↓	
Monochlorobutene			↑	→		↓	↑		↓	↓	↓	↓	↑	↓	
Monochlorohydrin													↑		

Fluid	NBR	EPDM	FKM	TPU	HNBR	CR	FMQ	MQ	IIR	BR	IR	SBR	FFKM	ACM	PTFE
Monoethanolamine (MEA)	↓	↑	↓	↓	↓	↓	↓	↑	↑	↑	↑	↑	↑	↓	
Monoethyl Amine	→	↑	→	↓	→	↑	↑	↑	↑	↑	↑	↑	↑	↓	
Monoisopropylamine	→	↑	→	↓	→	↑	↑	↑	↑	↑	↑	↑	↑	↓	
Monomethyl Aniline	↓	↑	↑	↓		↑	↑	↑	↑	↑	↑	↑	↑	↓	
Monomethyl Ether (Dimethyl Ether)													↑		
Monomethyl Ether (Methyl Ether)	↑	↓	↑										↑		
Monomethyl Hydrazine	↑	↑			↑	↑		↓	↑			↑	↑		
Monomethylamine (MMA)	→	↑	→	↓	→	↑	↑	↑	↑	↑	↑	↑	↑	↓	
Monomethylaniline	↓	↑	↑	↓	↓	↓			↑	↓	↓	↓	↑	↓	
Mononitrotoluene	→	↑	→	↓	→	↑	↑	↑	↑	↑	↑	↑	↑	↓	
Mononitrotoluene & Dinitrotoluene (40/60 Mixture)	↓	↑	→	↓	↓	↓	→	↓	↓	↓	↓	↓	↑	↓	
Monovinyl Acetylene	↑	↑	↑		↑	↑	↑	↑	↑	↑	↑	↑	↑		
Mopar Brake Fluid	→	↑	↓		→	↑	↓	→	↑				↑	↑	
Morpholine			↑	→		↓	↑		↓	↓	↓	↓	↑	↓	↑
Motor Oils	↑	↓	↑	↑	↑	↑	↑	↑	↓	↓	↓	↓	↑	↑	
Mustard Gas													↑		
Myristic Acid			↑	→		↓	↑		↓	↓	↓	↓	↑	↓	
Naphthalene	↓	↓	↑	↓	↓	↓	↑	↓	↓	↓	↓	↓	↑	↓	↑
Naphthalene Chloride			↑	→		↓	↑		↓	↓	↓	↓	↑	↓	
Naphthalene Sulfonic Acid			↑	→		↓	↑		↓	↓	↓	↓	↑	↓	
Naphthalenic Acid			↑	→		↓	↑		↓	↓	↓	↓	↑	↓	
Naphthenic Acid	↑	↓	↑		↑	↓	↑	↓	↓	↓	↓	↓	↑		

# Materials

Fluid	NBR	EPDM	FKM	TPU	HNBR	CR	FMQ	MQ	IIR	BR	IR	SBR	FFKM	ACM	PTFE
Naphthylamine													↑		
Naptha	↗	↓	↑	↗	↓	↗	↓	↓	↓	↓	↓	↓	↑	↗	↗
Natural Gas	↑	↓	↑	↗	↑	↗	↗	↓	↓	↗	↗	↗	↑	↑	↑
Neatsfoot Oil	↑	↗	↑	↑	↑	↓	↑	↗	↗	↓	↓	↓	↑	↑	
Neon	↑	↑	↑	↑	↑	↑	↑	↑	↑	↑	↑	↑	↑	↑	
Neville Acid	↓	↗	↑		↓	↓	↗	↓	↗	↓	↓	↓	↑	↓	
Nickel Acetate	↗	↑	↓	↓	↗	↗	↓	↓	↑	↓	↑	↓	↑	↓	↑
Nickel Ammonium Sulfate	→	↑	→	↓	→	↑	↗	↑	↑	↑	↑	↑	↑	↓	
Nickel Chloride	↑	↑	↑	→	↑	↗	↑	↑	↑	↑	↑	↑	↑	→	↑
Nickel Cyanide	→	↑	→	↓	→	↑	↗	↑	↑	↑	↑	↑	↑	↓	
Nickel Nitrate	↑	↑	↑		↑	↑	↗	↑	↑	↑	↑	↑	↑		
Nickel Salts	↑	↑	↑	→	↑	↗	↑	↑	↑	↑	↑	↑	↑	→	
Nickel Sulfate	↑	↑	↑	→	↑	↑	↑	↑	↑	↗	↗	↗	↑	↓	↑
Nicotinamide (Niacinamide)			↑	→	↓	↗		↓	↓	↓	↓	↓	↑	↓	
Nicotinamide Hydrochloride	→	↑	→	↓	→	↑	↗	↑	↑	↑	↑	↑	↑	↓	
Nicotine			↑	→	↓	↗		↓	↓	↓	↓	↓	↑	↓	
Nicotine Sulfate	→	↑	→	↓	→	↑	↗	↑	↑	↑	↑	↑	↑	↓	
Niter Cake	↑	↑	↑	↑	↑	↑	↑	↑	↑	↑	↑	↑	↑	↓	
Nitric Acid (0 - 50%)	↓	↗	↑										↑		
Nitric Acid (50 - 100%)	↓	↓	→										↑		
Nitric Acid 3 Molar to 70°C	↓	↗	→	↓	↓	↓	↓	↓	↗			→	↗	↓	
Nitric Acid Concentrated Room Temp.	↓	↗											↑	↑	

Fluid	NBR	EPDM	FKM	TPU	HNBR	CR	FMQ	MQ	IIR	BR	IR	SBR	FFKM	ACM	PTFE
Nitric Acid Concentrated to 70°C	↓	↓	↓	↓	↓	↓	↓	↓	↓			↓	↗	↓	↑
Nitric Acid, Red Fuming	↓	↓	↗		↓	↓							↑	↑	
Nitric Acid, White Fuming													↗	↑	
Nitroaniline	→	↑	→	↓	→	↑	↑	↗	↑	↑	↑	↑	↑	↓	
Nitrobenzene	↓	↓	↓	↓	↓	↓	↓	↓	↑	↓	↓	↓	↑	↓	↑
Nitrobenzoic Acid	→	↑	→	↓	→	↑	↑	↗	↑	↑	↑	↑	↑	↓	
Nitrocellulose	→	↑	→	↓	→	↑	↑	↗	↑	↑	↑	↑	↑	↓	
Nitrochlorobenzene	→	↑	→	↓	→	↑	↑	↗	↑	↑	↑	↑	↑	↓	
Nitrochloroform	→	↑	→	↓	→	↑	↑	↗	↑	↑	↑	↑	↑	↓	
Nitrodiethylaniline	→	↑	→	↓	→	↑	↑	↗	↑	↑	↑	↑	↑	↓	
Nitrodiphenyl Ether													↑		
Nitroethane	↓	↗	↓	↓	↓	↗	↓	↓	↗	↗	↗	↗	↑	↓	
Nitrofluorobenzene	→	↑	→	↓	→	↑	↑	↗	↑	↑	↑	↑	↑	↓	
Nitrogen	↑	↑	↑	↑	↑	↑	↑	↑	↑	↑	↑	↑	↑	↑	↑
Nitrogen Oxides	→	↑	→	↓	→	↑	↑	↗	↑	↑	↑	↑	↑	↓	
Nitrogen Tetroxide (N2O4)	↓	↓	↓	↓	↓	↓	↓	↓	→	↓	↓	↓	↗	↓	↑
Nitrogen Trifluoride													↗		
Nitroglycerine	→	↑	→	↓	→	↑	↑	↗	↑	↑	↑	↑	↑	↓	↑
Nitroglycerol	→	↑	→	↓	→	↑	↑	↗	↑	↑	↑	↑	↑	↓	
Nitroisopropylbenzene	→	↑	→	↓	→	↑	↑	↗	↑	↑	↑	↑	↑	↓	
Nitromethane	↓	↗	↓	↓	→	↓	↓	↗	↗	↗	→	↑	↓	↑	
Nitrophenol	→	↑	→	↓	→	↑	↑	↗	↑	↑	↑	↑	↑	↓	

Fluid	NBR	EPDM	FKM	TPU	HNBR	CR	FMQ	MQ	IIR	BR	IR	SBR	FFKM	ACM	PTFE
Nitropropane	↓	↗	↓	↓	↓	↓	↓	↓	↗	↓	↓	↓	↑	↓	↑
Nitrosyl Chloride													↑		
Nitrosylsulfuric Acid													↑		
Nitrothiophene	→	↑	→	↓	→	↑	↑	↗	↑	↑	↑	↑	↑	↓	
Nitrotoluene	→	↑	→	↓	→	↑	↑	↗	↑	↑	↑	↑	↑	↓	
Nitrous Acid	→	↑	→	↓	→	↑	↑	↗	↑	↑	↑	↑	↑	↓	
Nitrous Oxide	↑	↑	↑		↑			↑					↑		↑
Nonane	↑	↓	↑	↑	↑	↗	↑	↗	↓	↓	↓	↓	↑	↑	
Noryl GE Phenolic	↑	↑			↑										
Nyvac FR200 Mobil	↑	↑	↑		↑	↗			↓	↓		↓	↑		
Octachloro Toluene	↓	↓	↑	↓	↓	↗	↓	↓	↓	↓	↓	↓	↑	↓	
Octadecane	↑	↓	↑	↗	↑	↗	↑	↓	↓	↓	↓	↓	↑	↗	
Octanal (n-Octanaldehyde)	↑	↓	↑	↑	↑	↗	↑	↗	↓	↓	↓	↓	↑	↑	
Octane or n-Octane	↗	↓	↑	↓	↗	↓	↗	↓	↓	↓	↓	↓	↑	↓	↑
Octyl Acetate	→	↑	→	↓	→	↑	↑	↗	↑	↑	↑	↑	↑	↓	
Octyl Alcohol	↗	→	↑	↓	↗	↗	↗	↗	↗	↗	↗	↗	↑	↓	↑
Octyl Chloride	↑	↓	↑	↑	↑	↗	↑	↗	↓	↓	↓	↓	↑	↑	
Octyl Phthalate			↑	→	↓	↗			↓	↓	↓	↓	↑	↓	
Olefins			↑	→	↓	↗			↓	↓	↓	↓	↑	↓	
Oleic Acid	↗	↓	↑	↗	↗	↓			↓	↓	↓	↓	↑	↓	↑
Oleum (Fuming Sulfuric Acid)	↓	↓	↑	↓	↓	↓			↓	↓	↓	↓	↑	↓	
Oleum Spirits	↗	↓	↑	→	↗	→	↗	↓	↓	↓	↓	↓	↑		

# Materials

Fluid	NBR	EPDM	FKM	TPU	HNBR	CR	FMQ	MQ	IR	BR	IR	SBR	FFKM	ACM	PTFE
Oleyl Alcohol			↑	→		↓	↗		↓	↓	↓	↓	↑	↓	↑
Olive Oil	↑	↓	↑	↑	↑	↗	↑	→	↗	↓	↓	↓	↑	↑	↑
Oronite 8200	↗	↓	↑	↑	↗	↑	↑	↓	↓	↓	↓	↓	↑		
Oronite 8515	↗	↓	↑	↑	↗	↑	↑	↓	↓	↓	↓	↓	↑		
Ortho-Chloro Ethyl Benzene	↓	↓	↑	↓	↓	↓	↗	↓	↓	↓	↓	↓	↑	↓	
Ortho-Chloroaniline	→	↑	→	↓	→	↑	↑	↗	↑	↑	↑	↑	↑	↓	
Ortho-Chlorophenol	→	↑	→	↓	→	↑	↑	↗	↑	↑	↑	↑	↑	↓	
Ortho-Cresol	→	↑	→	↓	→	↑	↑	↗	↑	↑	↑	↑	↑	↓	
Ortho-Dichlorobenzene	↓	↓	↑	↓	↓	↓	↗	↓	↓	↓	↓	↓	↑	↓	
Ortho-Nitrotoluene	→	↑	→	↓	→	↑	↑	↗	↑	↑	↑	↑	↑	↓	
Orthophos Acid													↑		
OS 45 Type III (OS45)	↗	↓	↑	↓	↗	↑	↗	↓	↓	↓	↓	↓	↑		
OS 45 Type IV (OS45-1)	↗	↓	↑	↓	↗	↑	↗	↓	↓	↓	↓	↓	↑		
OS 70	↗	↓	↑	↓	↗	↑	↗	↓	↓	↓	↓	↓	↑		
Oxalic Acid	↗	↑	↑		↗	↗	↑	↗	↑	↗	↗	↗	↑		↑
Oxygen, 90-150 °C (Evaluate for specific applications)	↓	↓	↗		↓								↑		
Oxygen, 150-200 °C (Evaluate for specific applications)	↓	↓	↗	↓	↓	↓	↓	↑	↓	↓	↓	↓	↑	↓	
Oxygen, Cold (Evaluate for specific applications)	↗	↑	↑	↑	↗	↑	↑	↑	↑	↗	↗	↗	↑	↗	
Oxygen, Liquid	↓	↓	↓		↓	↓							↗		
Ozonated Deionized Water	→	↑	→	↓	→	↑	↑	↗	↑	↑	↑	↑	↗	↓	
Ozone	↓	↑	↑	↑	→	↗	↑	↑	↗	↓	↓	↓	↑	↗	↑
Paint Thinner, Duco	↓	↓	↗	↓	↓	↓	↗	↓	↓	↓	↓	↓	↑	↓	

Fluid	NBR	EPDM	FKM	TPU	HNBR	CR	FMQ	MQ	IR	BR	IR	SBR	FFKM	ACM	PTFE
Palmitic Acid	↗	→	↑	↗	↗	↗	↑	↓	↗	↗	↗	↗	↑	↓	↑
Par-al-Ketone	↓	↓	↓	↓	↓	↓	↓	↓	↓	↓	↓	↓		↓	
Para-Aminobenzoic Acid	→	↑	→	↓	→	↑	↑	↗	↑	↑	↑	↑	↑	↓	
Para-Aminosalicylic Acid	→	↑	→	↓	→	↑	↑	↗	↑	↑	↑	↑	↑	↓	
Para-Bromobenzylphenyl Ether													↑		
Para-Chlorophenol	→	↑	→	↓	→	↑	↑	↗	↑	↑	↑	↑	↑	↓	
Para-Dichlorobenzene	↓	↓	↑	↓	↓		↗	↓	↓	↓	↓	↓	↑	↓	
Para-Formaldehyde	→	↑	→	↓	→	↑	↑	↗	↑	↑	↑	↑	↑	↓	
Para-Nitroaniline	→	↑	→	↓	→	↑	↑	↗	↑	↑	↑	↑	↑	↓	
Para-Nitrobenzoic Acid	→	↑	→	↓	→	↑	↑	↗	↑	↑	↑	↑	↑	↓	
Para-Nitrophenol	→	↑	→	↓	→	↑	↑	↗	↑	↑	↑	↑	↑	↓	
Para-Toluene Sulfonic Acid	→	↑	→	↓	→	↑	↑	↗	↑	↑	↑	↑	↑	↓	
Paracymene			↑	→		↓	↗		↓	↓	↓	↓	↑	↓	
Paraffins	↑	↓	↑	↗	↑	↑	↑	↗	↓	↓	↓	↓	↑	↑	↑
Paraldehyde	→	↑	→	↓	→	↑	↑	↗	↑	↑	↑	↑	↑	↓	
Parathion			↑	→		↓	↗		↓	↓	↓	↓	↑	↓	
Parker O Lube	↑	↓	↑	↑	↑	↑	↑	↗	↓	↓	↓	↗	↑	↑	
Peanut Oil	↑	↓	↑	↑	↑	↓	↑	↑	→	↓	↓	↓	↑	↑	
Pectin (Liquor)			↑	→		↓	↗		↓	↓	↓	↓	↑	↓	↑
Pelagonic Acid													↑		
Penicillin (Liquid)			↑	→		↓	↗		↓	↓	↓	↓	↑	↓	
Pentachloroethane		↑	→		↓	↗		↓	↓	↓	↓	↓	↑	↓	

Fluid	NBR	EPDM	FKM	TPU	HNBR	CR	FMQ	MQ	IR	BR	IR	SBR	FFKM	ACM	PTFE
Pentachlorophenol	→	↗	→	↓	→	↑	↑	↗	↑	↑	↑	↑	↑	↓	
Pentaerythritol	→	↑	→	↓	→	↑	↑	↗	↑	↑	↑	↑	↑	↓	
Pentaerythritol Tetranitrate	→	↑	→	↓	→	↑	↑	↗	↑	↑	↑	↑	↑	↓	
Pentafluoroethane (F-125)													↗		
Pentane or n-Pentane	↑	↓	↑	↓	↑	↗	→	↓	↓	↓	↓	↓	→	↑	↑
Pentane, 2 Methyl	↑	↓	↑	↓	↑	↗	→	↓	↓	↓	↓	↓	↑	↑	
Pentane, 2-4 dimethyl	↑	↓	↑	↓	↑	↗	→	↓	↓	↓	↓	↓	↑	↑	
Pentane, 3-Methyl	↑	↓	↑	↓	↑	↗	→	↓	↓	↓	↓	↓	↑	↑	
Pentoxone													↑		
Pentyl Pentanoate	↑	↓	↑	↑	↑	↗	↑	↗	↓	↓	↓	↓	↑	↑	
Peracetic Acid	→	↑	→	↓	→	↑	↑	↗	↑	↑	↑	↑	↑	↓	↑
Perchloric Acid - 2N	↓	↗	↑	↓	↓	↗	↑	↗	↗	↓	↓	↓	↑	↓	
Perchloroethylene	↓	↓	↗	↓	↓	↓	↗	↓	↓	↓	↓	↓	↑	↓	↑
Perfluoropropane													↗		
Perfluorotriethylamine													↗		
Permanganic Acid													↑		
Persulfuric Acid (Caro's Acid)													↑		
Petrolatum	↑	↓	↑	↑	↑	↗	↑	↓	↓	↓	↓	↓	↑	↑	
Petrolatum Ether	↑	↓	↑	↑	↑	↗	↑	↗	↓	↓	↓	↓	↑	↑	
Petroleum Oil, Above 120 °C	↓	↓	↗	↓	↓	↓	↓	↓	↓	↓	↓	↓	↑	↓	
Petroleum Oil, Below 120 °C	↑	↓	↑	↗	↑	↗	↗	↗	↓	↓	↓	↓	↑	↗	
Petroleum Oil, Crude	↑	↓	↑	↑	↑	↗	↑	↓	↓	↓	↓	↓	↑	↑	

# Materials

Fluid	NBR	EPDM	FKM	TPU	HNBR	CR	FMQ	MQ	IIR	BR	IR	SBR	FFKM	ACM	PTFE
Phenol	↓	↓	↔	↓	↓	↓	↔	↓	↓	↓	↓	↓	↑	→	
Phenol, 70% / 30% H2O	↓	↓	↑	↓	↓	↔	↔	↓	↓	↓	↓	↓	↑	↓	
Phenol, 85% / 15% H2O	↓	↓	↑	↓	↓	↔	↔	↓	↓	↓	↓	↓	↑	↓	
Phenolic Sulfonate	→	↑	→	↓	→	↑	↑	↔	↑	↑	↑	↑	↑	↓	
Phenolsulfonic Acid	→	↑	→	↓	→	↑	↑	↔	↑	↑	↑	↑	↑	↓	
Phenylacetamide			↑	→	↓	↔		↓	↓	↓	↓	↓	↑	↓	
Phenylacetate	→	↑	→	↓	→	↑	↑	↔	↑	↑	↑	↑	↑	↓	
Phenylacetic Acid	→	↑	→	↓	→	↑	↑	↔	↑	↑	↑	↑	↑	↓	
Phenylbenzene	↓	↓	↔	↓	↓	↓	↔	↓	↓	↓	↓	↓	↑	↓	↑
Phenylene Diamine													↑		
Phenylethyl Alcohol			↑	→	↓	↔		↓	↓	↓	↓	↓	↑	↓	
Phenylethyl Ether	↓	↓	↓	↓	↓	↓	↓	↓	↓	↓	↓	↓	↑	↓	↑
Phenylethyl Malonic Ester *			↑	→	↓	↔		↓	↓	↓	↓	↓	↑	↓	
Phenylglycerine	→	↑	→	↓	→	↑	↑	↔	↑	↑	↑	↑	↑	↓	
Phenylhydrazine	↓	↓	↔	↓	↓				↓	↔	↔	↔	↑	↓	
Phenylhydrazine Hydrochloride	→	↑	→	↓	→	↑	↑	↔	↑	↑	↑	↑	↑	↓	
Phenylmercuric Acetate	→	↑	→	↓	→	↑	↑	↔	↑	↑	↑	↑	↑	↓	
Phorone	↓	→	↓	↓	↓	↓	↓	↓	→	↓	↓	↓	↑	↓	
Phosgene													↑		↑
Phosphine	↓	↑	↔	↓	↓	↔							↑	↓	
Phosphoric Acid 3 Molar to 70°C	↑	↑	↑	↓	↑	↔	↔	↔	↑			↔	↑	→	
Phosphoric Acid Concentrated Room Temp	↔	↑	↓	↔	↔	↔	↔	↔	↑			↑	↑	↔	

Fluid	NBR	EPDM	FKM	TPU	HNBR	CR	FMQ	MQ	IIR	BR	IR	SBR	FFKM	ACM	PTFE
Phosphoric Acid Concentrated to 70°C	↓	↑	↑	↓	↓	→	→	↓	↑			↔	↑	→	
Phosphoric Acid, 20%													↑		
Phosphoric Acid, 45%	↔	↑	↑	↓	↔	↔							↑	→	
Phosphorus (Molten)													↑		
Phosphorus Oxychloride													↑		↑
Phosphorus Trichloride	↓	↑	↑		↓	↓	↑		↑			↓	↑		↑
Phosphorus Trichloride Acid	↓	↑	↑		↓	↓							↑		
Phthalic Acid	↔	↑	↔	↓	↔	↔	↑	↔	↑	↑	↑	↑	↑	↓	↑
Phthalic Anhydride	→	↑	→	↓	→	↑	↑	↔	↑	↑	↑	↑	↑	↓	
Pickling Solution	↓	→	↔	↓	↓	↓	↓	↓	↓	→	↓	↓	↑	↓	↑
Picric Acid (aq)	↑	↑	↑		↑	↑	↔		↑	↔	↔	↔	↑		↑
Picric Acid Molten	↔	↔	↑		↔	↔	↔	↓	↔	↔	↔	↔	↑		
Pine Oil	↔	↓	↑	↑	↔	↓	↑	↓	↓	↓	↓	↓	↑	↑	↑
Pine Tar	↑	↓	↑	↑	↑	↔	↑	↔	↓	↓	↓	↓	↑	↑	
Pinene	↔	↓	↑	↔	↔	↔	↑	↓	↓	↓	↓	↓	↑	↓	↑
Piperazine			↑	→	↓	↔		↓	↓	↓	↓	↓	↑	↓	
Piperidine	↓	↓	↓	↓	↓	↓	↔	↓	↓	↓	↓	↓	↑	↓	↑
Piranha (H2SO4:H2O2)(70:30)													↑		
Plating Solution (Co,Cu, Au,In,Fe,Pb,Ni,Ag,Sn,Zn)	↑	↑	↑		↑								↑		
Plating Solutions Chrome	↓	↔	↑	↓	↓	↓	↔	↔	↔	↓	↓	↓	↑	↓	
Plating Solutions Others	↑	↑	↑		↑	↓		↓	↑			↓	↑		
Polyethylene Glycol	↔	↑	→		↔	↔							↑		

Fluid	NBR	EPDM	FKM	TPU	HNBR	CR	FMQ	MQ	IIR	BR	IR	SBR	FFKM	ACM	PTFE
Polyglycerol	→	↑	↑	↓	→	↑	↑	↔	↑	↑	↑	↑	↑	↓	
Polyglycol	→	↑	→	↓	→	↑	↑	↔	↑	↑	↑	↑	↑	↓	
Polyvinyl Acetate Emulsion		↑			↔			↑					↓	↑	
Potassium (Molten)														↓	
Potassium Acetate	↔	↑	↔	↔	↔	↔	↓	↓	↑	↓	↑	↓	↑	↓	↑
Potassium Acid Sulfate	→	↑	→	↓	→	↑	↑	↔	↑	↑	↑	↑	↑	↓	
Potassium Alum	→	↑	→	↓	→	↑	↑	↔	↑	↑	↑	↑	↑	↓	
Potassium Aluminum Sulfate	→	↑	→	↓	→	↑	↑	↔	↑	↑	↑	↑	↑	↓	
Potassium Antimonate	→	↑	→	↓	→	↑	↑	↔	↑	↑	↑	↑	↑	↓	
Potassium Bicarbonate	→	↑	→	↓	→	↑	↑	↔	↑	↑	↑	↑	↑	↓	
Potassium Bichromate	→	↑	→	↓	→	↑	↑	↔	↑	↑	↑	↑	↑	↓	
Potassium Bifluoride	→	↑	→	↓	→	↑	↑	↔	↑	↑	↑	↑	↑	↓	
Potassium Bisulfate	↑	↑	↑	↓	↑	↔	↑	↔	↑	↑	↑	↑	↑	↓	↑
Potassium Bisulfite	→	↑	→	↓	→	↑	↑	↔	↑	↑	↑	↑	↑	↓	
Potassium Bitartrate	→	↑	→	↓	→	↑	↑	↔	↑	↑	↑	↑	↑	↓	
Potassium Bromide	↑	↑	↑	↓	↑	↔	↑	↔	↑	↑	↑	↑	↑	↓	↑
Potassium Carbonate	↑	↑	↑	↓	↑	↔	↑	↔	↑	↑	↑	↑	↑	→	↑
Potassium Chlorate	↓	↑	↑	↓	↓	↔	↑	↔	↑	↑	↑	↑	↑	↓	↑
Potassium Chloride	↑	↑	↑	→	↑	↔	↑	↑	↑	↑	↑	↑	↑	→	↑
Potassium Chromates	↔	↑	↑	↓	↔	↔	↑	↔	↑	↑	↑	↑	↑	↓	↑
Potassium Citrate	→	↑	→	↓	→	↑	↑	↔	↑	↑	↑	↑	↑	↓	
Potassium Cupro Cyanide	↑	↑	↑	↑	↑	↑	↑	↑	↑	↑	↑	↑	↑	↑	



# Materials

Fluid	NBR	EPDM	FKM	TPU	HNBR	CR	FMQ	MQ	IIR	BR	IR	SBR	FFKM	ACM	PTFE
Potassium Cyanate	→	↑	→	↓	→	↑	↑	↑	↑	↑	↑	↑	↑	↓	
Potassium Cyanide	↑	↑	↑	↓	↑	↑	↑	↑	↑	↑	↑	↑	↑	↓	↑
Potassium Dichromate	↑	↑	↑	→	↑	↑	↑	↑	↑	↑	↑	↑	↑	↓	↑
Potassium Diphosphate	→	↑	→	↓	→	↑	↑	↑	↑	↑	↑	↑	↑	↓	
Potassium Ferricyanide	→	↑	→	↓	→	↑	↑	↑	↑	↑	↑	↑	↑	↓	
Potassium Fluoride	→	↑	→	↓	→	↑	↑	↑	↑	↑	↑	↑	↑	↓	
Potassium Glucocyanate	→	↑	→	↓	→	↑	↑	↑	↑	↑	↑	↑	↑	↓	
Potassium Hydroxide 50%	↑	↑	→	↓	↑	↑	↑	↑	↑	↑	↑	↑	↑	↓	↑
Potassium Hypochlorite	→	↑	→	↓	→	↑	↑	↑	↑	↑	↑	↑	↑	↓	
Potassium Iodate	→	↑	→	↓	→	↑	↑	↑	↑	↑	↑	↑	↑	↓	
Potassium Iodide	↑	↑	↑	↓	↑	↑	↑	↑	↑	↑	↑	↑	↑	↓	↑
Potassium Metabisulfate	→	↑	→	↓	→	↑	↑	↑	↑	↑	↑	↑	↑	↓	
Potassium Metachromate	→	↑	→	↓	→	↑	↑	↑	↑	↑	↑	↑	↑	↓	
Potassium Metasilicate													↑		
Potassium Monochromate	→	↑	→	↓	→	↑	↑	↑	↑	↑	↑	↑	↑	↓	
Potassium Nitrate	↑	↑	↑	→	↑	↑	↑	↑	↑	↑	↑	↑	↑	→	↑
Potassium Nitrite	→	↑	→	↓	→	↑	↑	↑	↑	↑	↑	↑	↑	↓	
Potassium Oxalate	→	↑	→	↓	→	↑	↑	↑	↑	↑	↑	↑	↑	↓	
Potassium Perchlorate	↓	↑	↑	↓	↓	↑	↑	↑	↑	↑	↑	↑	↑	↓	↑
Potassium Perfluoro Acetate	↑	↑	↓		↑	↑							↑		
Potassium Permanganate	↓	↑	↑	↑	↓	↑	↑	↑	↑	↑	↑	↑	↑	→	↑
Potassium Peroxide													↑		

Fluid	NBR	EPDM	FKM	TPU	HNBR	CR	FMQ	MQ	IIR	BR	IR	SBR	FFKM	ACM	PTFE
Potassium Persulfate	↓	↑	↑	↓	↓	↑	↑	↑	↑	↑	↑	↑	↑	↓	↑
Potassium Phosphate (Acid)	→	↑	↑	↓	→	↑	↑	↑	↑	↑	↑	↑	↑	↓	
Potassium Phosphate (Alkaline)	→	↑	→	↓	→	↑	↑	↑	↑	↑	↑	↑	↑	↓	
Potassium Phosphate (Di/Tri Basic)	→	↑	→	↓	→	↑	↑	↑	↑	↑	↑	↑	↑	↓	
Potassium Pyrosulfate	→	↑	→	↓	→	↑	↑	↑	↑	↑	↑	↑	↑	↓	↑
Potassium Salts	↑	↑	↑	↑	↑	↑	↑	↑	↑	↑	↑	↑	↑	↑	
Potassium Silicate													↑		
Potassium Sodium Tartrate	→	↑	→	↓	→	↑	↑	↑	↑	↑	↑	↑	↑	↓	
Potassium Stannate	→	↑	→	↓	→	↑	↑	↑	↑	↑	↑	↑	↑	↓	
Potassium Stearate	→	↑	→	↓	→	↑	↑	↑	↑	↑	↑	↑	↑	↓	
Potassium Sulfate	↑	↑	↑	→	↑	↑	↑	↑	↑	↑	↑	↑	↑	↓	
Potassium Sulfide	→	↑	→	↓	→	↑	↑	↑	↑	↑	↑	↑	↑	↓	
Potassium Sulfite	↑	↑	↑	→	↑	↑	↑	↑	↑	↑	↑	↑	↑	↓	
Potassium Tartrate	→	↑	→	↓	→	↑	↑	↑	↑	↑	↑	↑	↑	↓	
Potassium Thiocyanate	→	↑	→	↓	→	↑	↑	↑	↑	↑	↑	↑	↑	↓	
Potassium Thiosulfate	→	↑	→	↓	→	↑	↑	↑	↑	↑	↑	↑	↑	↓	
Potassium Triphosphate	→	↑	→	↓	→	↑	↑	↑	↑	↑	↑	↑	↑	↓	
Prestone Antifreeze	↑	↑	↑	↓	↑	↑	↑	↑	↑	↑	↑	↑	↑	↓	
PRL-High Temp. Hydr. Oil	↑	↓	↑	↑	↑	↑	↑	↑	↓	↓	↓	↓	↑	↑	
Producer Gas	↑	↓	↑	↑	↑	↑	↑	↑	↓	↓	↓	↓	↑	↑	
Propane	↑	↓	↑	↑	↑	↑	↑	↓	↓	↓	↓	↓	↑	↑	↑
Propionaldehyde	→	↑	→	↓	→	↑	↑	↑	↑	↑	↑	↑	↑	↓	

Fluid	NBR	EPDM	FKM	TPU	HNBR	CR	FMQ	MQ	IIR	BR	IR	SBR	FFKM	ACM	PTFE
Propionic Acid	→	↑	→	↓	→	↑	↑	↑	↑	↑	↑	↑	↑	↓	
Propionitrile	↑	↓	↑		↑	↑							↑		
Propyl Acetate	↓	↑	↓	↓	↓	↓	↓	↓	↑	↓	↓	↓	↑	↓	
Propyl Acetone or n-Propyl Acetone	↓	↑	↓	↓	↓	↓	↓	↓	↑	↓	↓	↓	↑	↓	
Propyl Alcohol	↑	↑	↑	↓	↑	↑	↑	↑	↑	↑	↑	↑	↑	↓	
Propyl Nitrate	↓	↑	↓	↓	↓	↓	↓	↑	↓	↓	↓	↓	↑	↓	
Propyl Propionate	→	↑	→	↓	→	↑	↑	↑	↑	↑	↑	↑	↑	↓	
Propylamine	↓	↓	↓	↓	↓	↑	↑	↑	↑	↑	↑	↑	↑	↓	
Propylbenzene			↑	→	↓	↑	↓	↓	↓	↓	↓	↓	↑	↓	
Propylene	↓	↓	↑	↓	↓	↓	→	↓	↓	↓	↓	↓	↑	↓	
Propylene Chloride			↑	→	↓	↑	↓	↓	↓	↓	↓	↓	↑	↓	
Propylene Chlorohydrin			↑	→	↓	↑	↓	↓	↓	↓	↓	↓	↑	↓	
Propylene Dichloride	↓	↓			↓	↑	↓	↓	↓	↓	↓	↓	↑	↓	
Propylene Glycol	↑	↑	↑	↓	↑	↑	↑	↑	↑	↑	↑	↑	↑	↓	↑
Propylene Imine			↑	→	↓	↑	↓	↓	↓	↓	↓	↓	↑	↓	
Propylene Oxide	↓	↑	↓	↓	↓	↓	↓	↓	↑	↓	↓	↓	↑	↓	↑
Pydraul 90e	↓	↑	↑		↓	↓							↑		
Pydraul, 10E	↓	↑	↓	↓	↓	↓	↓	↑	↑	↓	↓	↓	↑	↓	
Pydraul, 115E	↓	↑	↑	↓	↓	↓	→	↓	↑	↓	↓	↓	↑	↓	
Pydraul, 230C, 312C, 540C, A200	↓	↓	↑	↓	↓	↓	↓	↓	↓	↓	↓	↓	↑	↓	
Pydraul, 29ELT 30E, 50E, 65E	↓	↑	↑	↓	↓	↓	↑	↑	↑	↓	↓	↓	↑	↓	
Pyranol Transformer Oil	↑	↓	↑	↑	↑	↑	↓	↓	↓	↓	↓	↓	↑	↑	

# Materials

Fluid	NBR	EPDM	FKM	TPU	HNBR	CR	FMQ	MQ	IIR	BR	IR	SBR	FFKM	ACM	PTFE
Pyridine	↓	↓	↓	↓	↓	↓	↔		↓	↓	↓	↓	↑	↓	↑
Pyridine Oil	↓	↔	↓		↓	↓	↓	↔	↓	↓	↓	↓	↑	↓	
Pyridine Sulfate	↔	↑	↔	↓	↔	↑	↑	↔	↑	↑	↑	↑	↑	↓	
Pyridine Sulfonic Acid	↔	↑	↔	↓	↔	↑	↑	↔	↑	↑	↑	↑	↑	↓	
Pyrogallol (Pyrogalllic Acid)	↔	↓	↑	↔	↔	↔	↔		↓	↓	↓	↓	↑	↓	
Pyrogard 42, 43, 55	↓	↑	↑		↓	↓							↑		
Pyrogard 53, Mobil Phosphate Ester	↓	↑	↑	↓	↓	↓	↓	↓	↑	↓	↓	↓	↑	↓	
Pyrogard D, Mobil Water-in-Oil Emulsion	↑	↓	↓	↑	↑	↔	↔	↔	↓	↓	↓	↓	↑		
Pyroligeneous Acid	↓	↔	↓	↓	↓	↔	↓		↔	↓	↓	↓	↑	↓	
Pyrolube	↓	↔	↑	↓	↓	↓	↔	↔	↔	↓	↓	↓	↑	↓	
Pyrosulfuric Acid	↔	↑	↔	↓	↔	↑	↑	↔	↑	↑	↑	↑	↑	↓	
Pyrosulfuryl Chloride	↔	↓	↑	↔	↔	↔	↔		↓	↓	↓	↓	↑	↓	
Pyrrrole	↓	↓	↓		↓	↓	↔	↓	↔	↔	↔	↔	↑	↓	↑
Pyruvic Acid	↔	↑	↔	↓	↔	↑	↑	↔	↑	↑	↑	↑	↑	↓	
Quinidine	↔	↓	↑	↔	↔	↔	↔		↓	↓	↓	↓	↑	↓	
Quinine	↔	↓	↑	↔	↔	↔	↔		↓	↓	↓	↓	↑	↓	
Quinine Bisulfate	↔	↑	↔	↓	↔	↑	↑	↔	↑	↑	↑	↑	↑	↓	
Quinine Hydrochloride	↔	↑	↔	↓	↔	↑	↑	↔	↑	↑	↑	↑	↑	↓	
Quinine Sulfate	↔	↑	↔	↓	↔	↑	↑	↔	↑	↑	↑	↑	↑	↓	
Quinine Tartrate	↔	↑	↔	↓	↔	↑	↑	↔	↑	↑	↑	↑	↑	↓	
Quinizarin	↔	↓	↑	↔	↔	↔			↓	↓	↓	↓	↑	↓	
Quinoline	↔	↓	↑	↔	↔	↔			↓	↓	↓	↓	↑	↓	

Fluid	NBR	EPDM	FKM	TPU	HNBR	CR	FMQ	MQ	IIR	BR	IR	SBR	FFKM	ACM	PTFE
Quinone	↔	↓	↑	↔	↔	↔	↔		↓	↓	↓	↓	↑	↓	
Radiation (Gamma, 1.0 E+07 Rads)	↔	↔	↓	↓	↔		↓	↔	↓				↔		
Raffinate	↔	↓	↑	↔	↔	↔	↔		↓	↓	↓	↓	↑	↓	
Rapeseed Oil	↔	↓	↑	↔	↔	↔	↑	↓	↑	↓	↓	↓	↑	↔	↑
Red Line 100 Oil	↑	↓	↑	↑	↑	↔	↑	↓	↓	↓	↓	↓	↑	↑	
Red Oil (MIL-H-5606)	↑	↓	↑	↑	↑	↔	↑	↓	↓	↓	↓	↓	↑	↑	
Resorcinol	↔	↑	↔	↓	↔	↑	↑	↔	↑	↑	↑	↑	↑	↓	
Rhodium													↑		
Riboflavin	↔	↓	↑	↔	↔	↔	↔		↓	↓	↓	↓	↑	↓	
Ricinoleic Acid	↔	↓	↑	↔	↔	↔	↔		↓	↓	↓	↓	↑	↓	
RJ-1 (MIL-F-25558)	↑	↓	↑	↑	↑	↔	↑	↓	↓	↓	↓	↓	↑	↑	
RJ-4 (MIL-F-82522)	↔	↓	↑	↔	↔	↔	↔	↓	↓			↓	↑	↔	
Rosin	↔	↓	↑	↔	↔	↔	↔		↓	↓	↓	↓	↑	↓	
RP-1 (MIL-R-25576)	↑	↓	↑	↑	↑	↔	↑	↓	↓	↓	↓	↓	↑	↑	
Saccharin Solution	↔	↑	↔	↔	↔	↔	↔	↔	↑	↑	↑	↑	↑	↓	
Sal Ammoniac	↑	↑	↑	↑	↑	↑	↑	↔	↑	↑	↑	↑	↑	↑	
Salicylic Acid	↔	↑	↑	↑	↔	↑	↑		↑	↔	↔	↔	↑	↑	
Santo Safe 300	↓	↔	↑		↓	↓	↑	↑	↔	↓	↓	↓	↑	↓	
Sea (Salt) Water	↑	↑	↔	↔	↔	↔	↑	↑	↑	↑	↑	↑	↑	↓	↑
Sebacic Acid	↔	↑	↔	↓	↔	↑	↑	↔	↑	↑	↑	↑	↑	↓	
Selenic Acid	↔	↑	↔	↓	↔	↑	↑	↔	↑	↑	↑	↑	↑	↓	
Selenous Acid	↔	↑	↔	↓	↔	↑	↑	↔	↑	↑	↑	↑	↑	↓	

Fluid	NBR	EPDM	FKM	TPU	HNBR	CR	FMQ	MQ	IIR	BR	IR	SBR	FFKM	ACM	PTFE
Sewage	↑	↑	↑	↓	↑	↔	↑	↑	↑	↑	↑	↑	↑	↓	
SF 1154 GE Silicone Fluid	↔	↑	↑	↔	↔	↑	↑	↓	↑		↑	↑	↑	↑	
SF 1147 GE Silicone Fluid	↔	↔	↑		↔			↓	↔				↑		
SF96 GE Silicone Fluid	↔	↑	↑	↔	↔	↑	↑	↓	↑	↑	↑	↑	↑	↑	
Shell 3XF Mine Fluid (Fire resist hydr.)	↑	↓	↑	↓	↑	↔	↑		↓	↓	↓	↓	↑	↓	
Shell Alvania Grease #2	↑	↓	↑	↑	↑	↔	↑	↔	↓	↓	↓	↓	↑	↑	
Shell Carnea 19 and 29	↑	↓	↑	↔	↑	↑	↑		↓	↓	↓	↓	↑	↑	
Shell Diala	↑	↓	↑	↔	↔	↑	↑	↓	↓	↓	↓	↓	↑	↑	
Shell Iruis 905	↑	↓	↑	↑	↑	↔	↑	↓	↓	↓	↓	↓	↑	↑	
Shell Lo Hydrax 27 and 29	↑	↓	↑	↔	↑	↔	↑	↓	↓	↓	↓	↓	↑	↑	
Shell Macome 72	↑	↓	↑	↔	↑	↔	↑	↓	↓	↓	↓	↓	↑	↑	
Shell Tellus #32 Pet. Base	↑	↓	↑	↑	↑	↔	↑	↓	↓	↓	↓	↓	↑	↑	
Shell Tellus #68	↑	↓	↑	↑	↑	↔	↑	↓	↓	↓	↓	↓	↑	↑	
Shell Tellus 27 (Petroleum Base)	↑	↓	↑		↑	↔							↑		
Shell Tellus 33	↑	↓	↑		↑	↔							↑		
Shell UMF (5% Aromatic)	↑	↓	↑	↑	↑	↔	↑	↓	↓	↓	↓	↓	↑	↑	
Shellac	↔	↑	↔	↓	↔	↑	↑	↔	↑	↑	↑	↑	↑	↓	
Silane														↑	
Silicate Esters	↔	↓	↑	↑	↔	↑	↑	↓	↓	↓	↓	↓	↑		
Silicon Fluoride														↑	
Silicon Tetrachloride														↑	
Silicon Tetrafluoride														↑	

# Materials

Fluid	NBR	EPDM	FKM	TPU	HNBR	CR	FMQ	MQ	IR	BR	IR	SBR	FFKM	ACM	PTFE
Silicone Greases	↑	↑	↑	↑	↑	↑	↔	↔	↑	↑	↑	↑	↑	↑	↑
Silicone Oils	↑	↑	↑	↑	↑	↑	↔	↔	↑	↑	↑	↑	↑	↑	↑
Silver Bromide	↔	↑	↔	↓	↔	↑	↔	↔	↑	↑	↑	↑	↑	↓	
Silver Chloride	↔	↑	↔	↓	↔	↑	↔	↔	↑	↑	↑	↑	↑	↓	
Silver Cyanide	↔	↑	↔	↓	↔	↑	↔	↔	↑	↑	↑	↑	↑	↓	
Silver Nitrate	↔	↑	↑	↑	↔	↑	↑	↑	↑	↑	↑	↑	↑	↔	↑
Silver Sulfate	↔	↑	↔	↓	↔	↑	↔	↔	↑	↑	↑	↑	↑	↓	
Sinclair Opaline CX-EP Lube	↑	↓	↑	↑	↑	↔	↑	↓	↓	↓	↓	↓	↑	↑	
Skelly, Solvent B, C, E	↑	↓	↑		↑	↓	↑		↓	↓	↓	↓	↑		
Skydrol 500 B4	↓	↑	↓	↓	↓	↓	↔	↔	↔	↓	↓	↓	↑	↓	
Skydrol 7000	↓	↑	↔	↓	↓								↑	↓	
Skydrol LD-4	↓	↑	↓	↓	↓	↓	↔	↔	↔	↓	↓	↓	↑	↓	
Soap Solutions	↑	↑	↑	↔	↑	↔	↑	↑	↑	↑	↑	↔	↑	↔	↑
Socony Mobile Type A	↑	↓	↑	↔	↑	↔	↔	↓	↓	↓	↓	↓	↑	↑	
Socony Vacuum AMV AC781 (Grease)	↑	↓	↑	↔	↑	↔	↔	↓	↓	↓	↓	↓	↑	↑	
Socony Vacuum PD959B	↑	↓	↑	↑	↑	↔	↑	↓	↓	↓	↓	↓	↑	↑	
Soda Ash	↑	↑	↑		↑	↑	↑	↑	↑	↑	↑	↑			
Sodium (Molten)													↓		
Sodium Acetate	↔	↑	↓	↓	↔	↔	↓	↓	↑	↓	↓	↑	↑	↓	
Sodium Acid Bisulfate	↔	↑	↔	↓	↔	↑	↔	↔	↑	↑	↑	↑	↑	↓	
Sodium Acid Fluoride	↔	↑	↔	↓	↔	↑	↔	↔	↑	↑	↑	↑	↑	↓	
Sodium Acid Sulfate	↔	↑	↔	↓	↔	↑	↔	↔	↑	↑	↑	↑	↑	↓	

Fluid	NBR	EPDM	FKM	TPU	HNBR	CR	FMQ	MQ	IR	BR	IR	SBR	FFKM	ACM	PTFE
Sodium Aluminate	↔	↑	↔	↓	↔	↑	↑	↔	↑	↑	↑	↑	↑	↓	
Sodium Aluminate Sulfate	↔	↑	↔	↓	↔	↑	↑	↔	↑	↑	↑	↑	↑	↓	
Sodium Anthraquinone Disulfate	↔	↑	↔	↓	↔	↑	↑	↔	↑	↑	↑	↑	↑	↓	
Sodium Antimonate	↔	↑	↔	↓	↔	↑	↑	↔	↑	↑	↑	↑	↑	↓	
Sodium Arsenate	↔	↑	↔	↓	↔	↑	↑	↔	↑	↑	↑	↑	↑	↓	
Sodium Arsenite	↔	↑	↔	↓	↔	↑	↑	↔	↑	↑	↑	↑	↑	↓	
Sodium Benzoate	↑	↑	↑	↓	↑	↔	↑	↔	↑	↑	↑	↑	↑	↓	↑
Sodium Bicarbonate (Baking Soda)	↑	↑	↑		↑	↑	↑	↑	↑	↑	↑	↑	↑		↑
Sodium Bichromate	↔	↑	↔	↓	↔	↑	↑	↔	↑	↑	↑	↑	↑	↓	
Sodium Bifluoride	↔	↑	↔	↓	↔	↑	↑	↔	↑	↑	↑	↑	↑	↓	
Sodium Bisulfate or Bisulfite	↑	↑	↑		↑	↑	↑	↑	↑	↔	↔	↔	↑	↓	↑
Sodium Bisulfide	↔	↑	↔	↓	↔	↑	↑	↔	↑	↑	↑	↑	↑	↓	
Sodium Bitartrate	↔	↑	↔	↓	↔	↑	↑	↔	↑	↑	↑	↑	↑	↓	
Sodium Borate	↔	↑	↑	↓	↔	↑	↑	↑	↑	↑	↑	↑	↑	↓	
Sodium Bromate	↔	↑	↔	↓	↔	↑	↑	↔	↑	↑	↑	↑	↑	↓	
Sodium Bromide	↔	↑	↔	↓	↔	↑	↑	↔	↑	↑	↑	↑	↑	↓	
Sodium Carbonate (Soda Ash)	↑	↑	↑	↓	↑	↑	↑	↑	↑	↑	↑	↑	↑	↓	
Sodium Chlorate	↔	↑	↑	↔	↔	↔	↔	↔	↑	↑	↑	↑	↑	↓	↑
Sodium Chloride	↑	↑	↑	↓	↑	↑		↑	↑	↑	↑	↑	↑	↓	↑
Sodium Chlorite	↓	↑	↑	↓	↓	↓	↑	↔	↑	↑	↑	↑	↑	↓	
Sodium Chloroacetate	↔	↑	↔	↓	↔	↑	↑	↔	↑	↑	↑	↑	↑	↓	
Sodium Chromate	↔	↑	↔	↓	↔	↑	↑	↔	↑	↑	↑	↑	↑	↓	

Fluid	NBR	EPDM	FKM	TPU	HNBR	CR	FMQ	MQ	IR	BR	IR	SBR	FFKM	ACM	PTFE
Sodium Citrate	↔	↑	↔	↓	↔	↑	↑	↔	↑	↑	↑	↑	↑	↓	
Sodium Cyanamide	↔	↑	↔	↓	↔	↑	↑	↔	↑	↑	↑	↑	↑	↓	
Sodium Cyanate	↔	↑	↔	↓	↔	↑	↑	↔	↑	↑	↑	↑	↑	↓	
Sodium Cyanide	↑	↑			↑	↑			↑	↑	↑	↑	↑		
Sodium Diacetate	↔	↑	↔	↓	↔	↑	↑	↔	↑	↑	↑	↑	↑	↓	
Sodium Diphenyl Sulfonate	↔	↑	↔	↓	↔	↑	↑	↔	↑	↑	↑	↑	↑	↓	
Sodium Diphosphate	↔	↑	↔	↓	↔	↑	↑	↔	↑	↑	↑	↑	↑	↓	
Sodium Disilicate	↔	↑	↔	↓	↔	↑	↑	↔	↑	↑	↑	↑	↑	↓	
Sodium Ethylate	↔	↑	↔	↓	↔	↑	↑	↔	↑	↑	↑	↑	↑	↓	
Sodium Ferricyanide	↔	↑	↔	↓	↔	↑	↑	↔	↑	↑	↑	↑	↑	↓	
Sodium Ferrocyanide	↔	↑	↔	↓	↔	↑	↑	↔	↑	↑	↑	↑	↑	↓	
Sodium Fluoride	↑	↑	↑	↔	↑		↑	↔	↑	↑	↑	↑	↑	↓	
Sodium Fluorosilicate	↔	↑	↔	↓	↔	↑	↑	↔	↑	↑	↑	↑	↑	↓	
Sodium Glutamate	↔	↑	↔	↓	↔	↑	↑	↔	↑	↑	↑	↑	↑	↓	
Sodium Hydride													↑		
Sodium Hydrogen Sulfate	↔	↑	↔	↓	↔	↑	↑	↔	↑	↑	↑	↑	↑	↓	
Sodium Hydrosulfide	↔	↑	↔	↓	↔	↑	↑	↔	↑	↑	↑	↑	↑	↓	
Sodium Hydrosulfite	↔	↑	↔	↓	↔	↑	↑	↔	↑	↑	↑	↑	↑	↓	
Sodium Hydroxide, 3 Molar	↔	↑	↔	↓	↔	↑	↑	↔	↑	↑	↑	↑	↑	↓	
Sodium Hypochlorite	↔	↑	↑	↓	↔	↔	↔	↔	↑	↔	↔	↔	↑	↓	↑
Sodium Hypophosphate	↔	↑	↔	↓	↔	↑	↑	↔	↑	↑	↑	↑	↑	↓	
Sodium Hypophosphite	↔	↑	↔	↓	↔	↑	↑	↔	↑	↑	↑	↑	↑	↓	

# Materials

Fluid	NBR	EPDM	FKM	TPU	HNBR	CR	FMQ	MQ	IIR	BR	IR	SBR	FFKM	ACM	PTFE
Sodium Hyposulfite	→	→	→	→	→	→	→	→	→	→	→	→	→	→	→
Sodium Iodide	→	→	→	→	→	→	→	→	→	→	→	→	→	→	→
Sodium Lactate	→	→	→	→	→	→	→	→	→	→	→	→	→	→	→
Sodium Metaphosphate	→	→	→	→	→	→	→	→	→	→	→	→	→	→	→
Sodium Metasilicate	→	→	→	→	→	→	→	→	→	→	→	→	→	→	→
Sodium Methylate	→	→	→	→	→	→	→	→	→	→	→	→	→	→	→
Sodium Monophosphate	→	→	→	→	→	→	→	→	→	→	→	→	→	→	→
Sodium Nitrate	→	→	→	→	→	→	→	→	→	→	→	→	→	→	→
Sodium Oleate	→	→	→	→	→	→	→	→	→	→	→	→	→	→	→
Sodium Orthosilicate	→	→	→	→	→	→	→	→	→	→	→	→	→	→	→
Sodium Oxalate	→	→	→	→	→	→	→	→	→	→	→	→	→	→	→
Sodium Perborate	→	→	→	→	→	→	→	→	→	→	→	→	→	→	→
Sodium Percarbonate	→	→	→	→	→	→	→	→	→	→	→	→	→	→	→
Sodium Perchlorate	→	→	→	→	→	→	→	→	→	→	→	→	→	→	→
Sodium Peroxide	→	→	→	→	→	→	→	→	→	→	→	→	→	→	→
Sodium Persulfate	→	→	→	→	→	→	→	→	→	→	→	→	→	→	→
Sodium Phenolate	→	→	→	→	→	→	→	→	→	→	→	→	→	→	→
Sodium Phenoxide	→	→	→	→	→	→	→	→	→	→	→	→	→	→	→
Sodium Phosphate (Dibasic)	→	→	→	→	→	→	→	→	→	→	→	→	→	→	→
Sodium Phosphate (Mono)	→	→	→	→	→	→	→	→	→	→	→	→	→	→	→
Sodium Phosphate (Tribasic)	→	→	→	→	→	→	→	→	→	→	→	→	→	→	→
Sodium Plumbite	→	→	→	→	→	→	→	→	→	→	→	→	→	→	→

Fluid	NBR	EPDM	FKM	TPU	HNBR	CR	FMQ	MQ	IIR	BR	IR	SBR	FFKM	ACM	PTFE
Sodium Pyrophosphate	→	→	→	→	→	→	→	→	→	→	→	→	→	→	→
Sodium Resinate	→	→	→	→	→	→	→	→	→	→	→	→	→	→	→
Sodium Salicylate	→	→	→	→	→	→	→	→	→	→	→	→	→	→	→
Sodium Salts	→	→	→	→	→	→	→	→	→	→	→	→	→	→	→
Sodium Sesquisilicate															
Sodium Silicate	→	→	→	→	→	→	→	→	→	→	→	→	→	→	→
Sodium Silicofluoride															
Sodium Stannate	→	→	→	→	→	→	→	→	→	→	→	→	→	→	→
Sodium Sulfate	→	→	→	→	→	→	→	→	→	→	→	→	→	→	→
Sodium Sulfide and Sulfite	→	→	→	→	→	→	→	→	→	→	→	→	→	→	→
Sodium Sulfocyanide	→	→	→	→	→	→	→	→	→	→	→	→	→	→	→
Sodium Tartrate	→	→	→	→	→	→	→	→	→	→	→	→	→	→	→
Sodium Tetraborate	→	→	→	→	→	→	→	→	→	→	→	→	→	→	→
Sodium Tetraphosphate	→	→	→	→	→	→	→	→	→	→	→	→	→	→	→
Sodium Tetrasulfide	→	→	→	→	→	→	→	→	→	→	→	→	→	→	→
Sodium Thioarsenate	→	→	→	→	→	→	→	→	→	→	→	→	→	→	→
Sodium Thiocyanate	→	→	→	→	→	→	→	→	→	→	→	→	→	→	→
Sodium Thiosulfate	→	→	→	→	→	→	→	→	→	→	→	→	→	→	→
Sodium Trichloroacetate	→	→	→	→	→	→	→	→	→	→	→	→	→	→	→
Sodium Triphosphate	→	→	→	→	→	→	→	→	→	→	→	→	→	→	→
Solvesso 100, 150															
Sorbitol	→	→	→	→	→	→	→	→	→	→	→	→	→	→	→

Fluid	NBR	EPDM	FKM	TPU	HNBR	CR	FMQ	MQ	IIR	BR	IR	SBR	FFKM	ACM	PTFE
Sour Crude Oil	→	→	→	→	→	→	→	→	→	→	→	→	→	→	→
Sour Natural Gas	→	→	→	→	→	→	→	→	→	→	→	→	→	→	→
Sovasol No. 1, 2, and 3	→	→	→	→	→	→	→	→	→	→	→	→	→	→	→
Sovasol No. 73 and 74	→	→	→	→	→	→	→	→	→	→	→	→	→	→	→
Soybean Oil	→	→	→	→	→	→	→	→	→	→	→	→	→	→	→
Spry	→	→	→	→	→	→	→	→	→	→	→	→	→	→	→
SR-10 Fuel	→	→	→	→	→	→	→	→	→	→	→	→	→	→	→
SR-6 Fuel	→	→	→	→	→	→	→	→	→	→	→	→	→	→	→
Standard Oil Mobilube GX90-EP Lube	→	→	→	→	→	→	→	→	→	→	→	→	→	→	→
Stannic Ammonium Chloride	→	→	→	→	→	→	→	→	→	→	→	→	→	→	→
Stannic Chloride	→	→	→	→	→	→	→	→	→	→	→	→	→	→	→
Stannic Chloride, 50%	→	→	→	→	→	→	→	→	→	→	→	→	→	→	→
Stannic Tetrachloride	→	→	→	→	→	→	→	→	→	→	→	→	→	→	→
Stannous Bisulfate	→	→	→	→	→	→	→	→	→	→	→	→	→	→	→
Stannous Bromide	→	→	→	→	→	→	→	→	→	→	→	→	→	→	→
Stannous Chloride (15%)	→	→	→	→	→	→	→	→	→	→	→	→	→	→	→
Stannous Fluoride	→	→	→	→	→	→	→	→	→	→	→	→	→	→	→
Stannous Sulfate	→	→	→	→	→	→	→	→	→	→	→	→	→	→	→
Stauffer 7700	→	→	→	→	→	→	→	→	→	→	→	→	→	→	→
Steam Below 200 °C	→	→	→	→	→	→	→	→	→	→	→	→	→	→	→
Steam, 200-260 °C	→	→	→	→	→	→	→	→	→	→	→	→	→	→	→
Steam, Above 260 °C															

# Materials

Fluid	NBR	EPDM	FKM	TPU	HNBR	CR	FMQ	MQ	IR	BR	IR	SBR	FFKM	ACM	PTFE
Stearic Acid	↗	↗	↗	↗	↗		↗	↗	↗	↗	↗	↗	↗	↗	↗
Stoddard Solvent	↗	↘	↗	↗	↗	↗	↘	↘	↘	↘	↘	↘	↗	↗	↗
Strontium Acetate	→	↗	→	↘	→	↗	↗	↗	↗	↗	↗	↗	↗	↘	
Strontium Carbonate	→	↗	→	↘	→	↗	↗	↗	↗	↗	↗	↗	↗	↘	
Strontium Chloride	→	↗	→	↘	→	↗	↗	↗	↗	↗	↗	↗	↗	↘	
Strontium Hydroxide	→	↗	→	↘	→	↗	↗	↗	↗	↗	↗	↗	↗	↘	
Strontium Nitrate	→	↗	→	↘	→	↗	↗	↗	↗	↗	↗	↗	↗	↘	
Styrene (Monomer)	↘	↘	↗	↘	↘	↘	→	↘	↘	↘	↘	↘	↘	↘	↗
Succinic Acid	↗	↗	↗	↘	↗	↗	↗	↗	↗	↗	↗	↗	↗	↘	↗
Sucrose Solutions	↗	↗	↗	↘	↗	↗	↗	↗	↗	↗	↗	↗	↗	↘	
Sulfamic Acid	→	↗	→	↘	→	↗	↗	↗	↗	↗	↗	↗	↗	↘	
Sulfanilic Acid	→	↗	→	↘	→	↗	↗	↗	↗	↗	↗	↗	↗	↘	
Sulfanilic Chloride	↗	↘	↗	→	↗	↘	↗		↘	↘	↘	↘	↗	↘	
Sulfanilimide	↗	↘	↗	→	↗	↘	↗		↘	↘	↘	↘	↗	↘	
Sulfite Liquors	→	↗	→	↘	→	↗	↗	↗	↗	↗	↗	↗	↗	↘	
Sulfolane	↗	↗	↗	↗	↗	↗						↗			
Sulfonated Oils	↗	↘	↗	→	↗	↘	↗		↘	↘	↘	↘	↗	↘	
Sulfonic Acid	→	↗	→	↘	→	↗	↗	↗	↗	↗	↗	↗	↗	↘	
Sulfonyl Chloride	→	↗	→	↘	→	↗	↗	↗	↗	↗	↗	↗	↗	↘	
Sulfur	↘	↗	↗		↘	↗	↗		↗	↘	↘	↘	↗	↘	↗
Sulfur (Molten)	↘	→	↗	↘	↘	→	→	→	→	↘	↘	↘	↗	↘	
Sulfur Chloride	↘	↘	↗	↘	↘	↘	↗	→	↘	↘	↘	↘	↗	↘	↗

Fluid	NBR	EPDM	FKM	TPU	HNBR	CR	FMQ	MQ	IR	BR	IR	SBR	FFKM	ACM	PTFE
Sulfur Dioxide, Dry	↘	↗	↘		↘	↘	↗	↗	↗	↗	↗	↗	↗	↘	↗
Sulfur Dioxide, Liquidified under pressure	↘	↗	↘		↘	↘	↗	↗	↗	↘	↘	↘	↗	↘	
Sulfur Dioxide, Wet	↘	↗	↘		↘	↗	↗	↗	↗	↘	↘	↘	↗	↘	
Sulfur Hexafluoride	↗	↗	↗		↗	↗							↗	↗	↗
Sulfur Liquors	↗	↗	↗		↗	↗	↘	↗	↗	↗	↗	↗	↗	↘	
Sulfur Monochloride	↗	↘	↗	↗	↗	↗	↗	↘	↘	↘	↘	↘	↗	↗	
Sulfur Tetrafluoride													↗		
Sulfur Trioxide Dry	↘	↗	↗		↘	↘	↗	↗	↗	↗	↗	→	↗	↘	
Sulfuric Acid (20% Oleum)	→	↗	→	↘	→	↗	↗	↗	↗	↗	↗	↗	↗	↘	
Sulfuric Acid, 3 Molar to 70°C	↗	↗	↗	↘	↗	↗	↗	↗				→	↗	↗	
Sulfuric Acid, Concentrated Room Temp		→	↗	→									↗	↗	
Sulfuric Acid, Concentrated to 70°C	↘	↘	↗	↘		↘	↘	↘				↘	↗	↘	↗
Sulfuric Chlorohydrin (Chlorosulfonic Acid)	→	↗	→	↘	→	↗	↗	↗	↗	↗	↗	↗	↗	↘	
Sulfurous Acid		↗	↗	↘			↘	↗	↗	↗	↗	↗	↗	↘	
Sunoco #3661	↗	↘	↗	↗	↗	↗	↗	↘	↘	↘	↘	↘	↗	↗	
Sunoco All purpose grease	↗	↘	↗	↗	↗	↗	↗	↘	↘	↘	↘	↘	↗	↗	
Sunoco SAE 10	↗	↘	↗	↗	↗	↗	↗	↘	↘	↘	↘	↘	↗	↗	
SunSAFE (Fire resist. hydr. fluid)	↗	↘	↗	↘	↗	↗		↘	↘	↘	↘	↘	↗	↘	
Super Shell Gas	↗	↘	↗	↗	↗	↗	↘	↘	↘	↘	↘	↘	↗	↗	
Surfuryl Chloride	→	↗	→	↘	→	↗	↗	↗	↗	↗	↗	↗	↗	↘	
Swan Finch EP Lube	↗	↘	↗	↗	↗	↘	↗	↘	↘	↘	↘	↘	↗	↗	
Swan Finch Hypoid-90	↗	↘	↗	↗	↗	↗	↘	↘	↘	↘	↘	↘	↗	↗	

Fluid	NBR	EPDM	FKM	TPU	HNBR	CR	FMQ	MQ	IR	BR	IR	SBR	FFKM	ACM	PTFE
Tannic Acid (10%)	↗	↗	↗		↗	↗	↗	↗	↗	↗	↗	↗	↗	↘	↗
Tar, bituminous	↘	↘	↗	↘	↘	↘	↗	↗	↘	↘	↘	↘	↗	↘	↗
Tartaric Acid	↗	↗	↗	↘	↗	↗	↗	↗	↗	↗	↗	↘	↗	↘	↗
Tellone II													↗		
Terephthalic Acid	→	↗	→	↘	→	↗	↗	↗	↗	↗	↗	↗	↗	↘	
Terpineol	↗	→	↗	↗	↗	↘	↗		→	↘	↘	↘	↗		
Terpinyl Acetate	↗	↘	↗	→	↗	↘	↗		↘	↘	↘	↘	↗	↘	
Tertiary Amyl Methyl Ether (TAME)													↗		
Tertiary Butyl Catechol or p-tert-butylcatechol	↘	↗	↗	↘	↘	↗	↗		↗	↗	↗	↗	↗	↘	
Tertiary Butyl Mercaptan	↘	↘	↗		↘								↗		
Tetrabromoethane	↘	↘	↗		↘	↘	↗	↘	↘	↘	↘	↘	↗	↘	
Tetrabromomethane	↗	↘	↗	→	↗	↘	↗		↘	↘	↘	↘	↗	↘	
Tetrabutyl Titanate	↗	↗	↗		↗	↗	↘	↘	↗	↗	↗	↗	↗		
Tetrachloroethane	↘	↘	↗	↘	↘	↘	↗		↘	↘	↘	↘	↗	↘	↗
Tetrachloroethylene	↘	↘	↗	↘	↘	↘	↗	↘	↘	↘	↘	↘	↗	↘	↗
Tetraethyl Lead	↗	↘	↗		↗	↘	↗		↘	↘	↘	↘	↗		↗
Tetraethyl Lead "Blend"	↗	↘	↗		↗	↘	↗		↘	↘	↘	↘	↗		
Tetraethyl Orthosilicate (TEOS)													↗		
Tetrahydrofuran	↘	↘	↘	↘	↘	↘	↘	↘	↘	↘	↘	↘	↗	↘	↗
Tetralin	↘	↘	↗		↘	↘	↗	↘	↘	↘	↘	↘	↗		
Tetramethyl Ammonium Hydroxide	→	↗	→	↘	→	↗	↗	↗	↗	↗	↗	↗	↗	↘	
Tetramethylcyclotetrasiloxane (TMCTS)													↗		

# Materials

Fluid	NBR	EPDM	FKM	TPU	HNBR	CR	FMQ	MQ	IIR	BR	IR	SBR	FFKM	ACM	PTFE
Tetramethylidihydropyridine	↗	↘	↗	↗	↗	↘	↗		↘	↘	↘	↘	↗	↘	
Tetraphosphoglucosate	→	↗	→	↘	→	↗	↗	↗	↗	↗	↗	↗	↗	↘	
Tetraphosphoric Acid													↗		
Texaco 3450 Gear Oil	↗	↘	↗	↗	↗	↘	↗	↘	↘	↘	↘	↘	↗	↗	
Texaco Capella A and AA	↗	↘	↗	↗	↗	↗	↘	↘	↘	↘	↘	↘	↗	↗	
Texaco Meropa 220 (No Lead)	↗	↘	↗	↗	↗	↗	↘	↘	↘	↘	↘	↘	↗	↗	
Texaco Regal B	↗	↘	↗	↗	↗	↘	↗	↘	↘	↘	↘	↘	↗	↗	
Texaco Uni-Temp Grease	↗	↘	↗	↗	↗	↗	↗	↘	↘	↘	↘	↘	↗	↗	
Texamatic "A" 1581 Fluid	↗	↘	↗	↗	↗	↗	↘	↘	↘	↘	↘	↘	↗	↗	
Texamatic "A" 3401 Fluid	↗	↘	↗	↗	↗	↗	↘	↘	↘	↘	↘	↘	↗	↗	
Texamatic "A" 3525 Fluid	↗	↘	↗	↗	↗	↗	↘	↘	↘	↘	↘	↘	↗	↗	
Texamatic "A" 3528 Fluid	↗	↘	↗	↗	↗	↗	↘	↘	↘	↘	↘	↘	↗	↗	
Texamatic "A" Transmission Oil	↗	↘	↗	↗	↗	↗	↘	↘	↘	↘	↘	↘	↗	↗	
Texas 1500 Oil	↗	↘	↗	↗	↗	↗	↘	↘	↘	↘	↘	↘	↗	↗	
Therminol 44	↘	↘	↗		↘	↘	↘	↘					↗	↘	
Therminol 55	↗	↘	↗		↘	↘	↘	↘					↗	↗	
Therminol 66													↗		
Therminol FR													↗		
Therminol VP-1, 60, 65	↘	↘	↗		↘	↘	↗	↘					↗	↘	
Thio Acid Chloride													↗		
Thioamyl Alcohol	↗	↘	↗	↗	↗	↗	↗	↘	↘	↘	↘	↘	↗	↗	
Thiodiacetic Acid	→	↗	→	↘	→	↗	↗	↗	↗	↗	↗	↗	↗	↘	

Fluid	NBR	EPDM	FKM	TPU	HNBR	CR	FMQ	MQ	IIR	BR	IR	SBR	FFKM	ACM	PTFE
Thioethanol	→	↗	↘	↘	→	↗	↗	↗	↗	↗	↗	↗	↗	↘	
Thioglycolic Acid	→	↗	→	↘	→	↗	↗	↗	↗	↗	↗	↗	↗	↘	
Thiokol TP-90B	↘	↗	↗		↘	↗	↗		↗			↘	↗		
Thiokol TP-95	↘	↗	↗		↘	↗	↗		↗			↘	↗		
Thionyl Chloride	↘	↗	↗	↘	↘	↗			↘	↘	↘	↘	↗	↘	↗
Thiophene (Thiofuran)	↘	↘	↘	↘	↘	↗			↘	↘	↘	↘	↗	↘	↗
Thiophosphoryl Chloride	→	↗	↘	↘	→	↗	↗	↗	↗	↗	↗	↗	↗	↘	
Thiourea	→	↗	→	↘	→	↗	↗	↗	↗	↗	↗	↗	↗	↘	
Thorium Nitrate	→	↗	→	↘	→	↗	↗	↗	↗	↗	↗	↗	↗	↘	
Tidewater Multigear, 140 EP Lube	↗	↘	↗	↗	↗	↗	↘	↘	↘	↘	↘	↘	↗	↗	
Tidewater Oil-Beedol	↗	↘	↗	↗	↗	↗	↘	↘	↘	↘	↘	↘	↗	↗	
Tin Ammonium Chloride	→	↗	→	↘	→	↗	↗	↗	↗	↗	↗	↗	↗	↘	
Tin Chloride	↗	↘	↗	↗	↗	↗	↗	↗	↘	↘	↘	↘	↗	↗	
Tin Tetrachloride	↗	↘	↗	↗	↗	↗	↗	↗	↘	↘	↘	↘	↗	↗	
Titanium Dioxide	→	↗	→	↘	→	↗	↗	↗	↗	↗	↗	↗	↗	↘	
Titanium Sulfate	→	↗	→	↘	→	↗	↗	↗	↗	↗	↗	↗	↗	↘	
Titanium Tetrachloride	↗	↘	↗	↘	↘	↗	↘	↘	↘	↘	↘	↘	↗	↘	↗
Toluene	↘	↘	↗	↘	↘	↘	↗	↘	↘	↘	↘	↘	↗	↘	↗
Toluene Bisodium Sulfite													↗		
Toluene Diisocyanate (TDI)	↘	↗	↘		↘	↘	↘	↘	↗	↘	↘	↘	↗	↘	
Toluene Sulfonyl Chloride	↗	↘	↗	→	↘	↘	↗		↘	↘	↘	↘	↗	↘	
Toluenesulfonic Acid	→	↗	→	↘	→	↗	↗	↗	↗	↗	↗	↗	↗	↘	

Fluid	NBR	EPDM	FKM	TPU	HNBR	CR	FMQ	MQ	IIR	BR	IR	SBR	FFKM	ACM	PTFE
Toluidine	↗	↘	↘	↗	↗	↘	↗		↘	↘	↘	↘	↗	↘	
Toluol	→	↗	→	↘	→	↗	↗	↗	↗	↗	↗	↗	↗	↘	
Toluquinone	↗	↘	↘	→	↗	↘	↗		↘	↘	↘	↘	↗	↘	
Tolylaldehyde	→	↗	→	↘	→	↗	↗	↗	↗	↗	↗	↗	↗	↘	
Transformer Oil	↗	↘	↘	↗	↗	↘	↗	↗	↘	↘	↘	↘	↗	↗	↗
Transmission Fluid Type A	↗	↘	↘	↗	↗	↗	↗	↗	↘	↘	↘	↘	↗	↗	↗
Triacetin	↗	↘	↘	↘	↗	↗	↘		↗	↗	↗	→	↗	↘	↗
Triaryl Phosphate	↘	↘	↘	↘	↘	↗	→	↗	↘	↘	↘	↘	↗	↘	
Tribromomethylbenzene	↗	↘	↘	→	↗	↘	↗		↘	↘	↘	↘	↗	↘	
Tributoxyethyl Phosphate	↘	↘	↘	↘	↘	↗		↗	↗	↘	↗	↗	↗	↘	↗
Tributyl Citrate	→	↗	→	↘	→	↗	↗	↗	↗	↗	↗	↗	↗	↘	
Tributyl Mercaptan	↘	↘	↗		↘	↘	→	↘	↘	↘	↘	↘	↗	↘	
Tributyl Phosphate	↘	↘	↘	↘	↘	↘	↘	↘	↗	↘	↗	↘	↗	↘	↗
Tributylamine													↗		
Trichloroacetic Acid	↗	↗	↘	↘	↗	↘	↘		↗	↗	↗	↗	↗	↘	↗
Trichloroacetyl Chloride	↗	↘	↘	→	↗	↘	↗		↘	↘	↘	↘	↗	↘	
Trichlorobenzene	↗		↘	↘	↘	↗			↘	↘	↘	↘	↗	↘	
Trichloroethane	↘	↘	↘	↘	↘	↗	↘	↘	↘	↘	↘	↘	↗	↘	
Trichloroethanolamine	→	↗	→	↘	→	↗	↗	↗	↗	↗	↗	↗	↗	↘	
Trichloroethylene	↘	↘	↗	↘	↘	↗	↘	↘	↘	↘	↘	↘	↗	↘	↗
Trichloromethane	↘	↘	↘	↘	↘	↗	↘	↘	↘	↘	↘	↘	↗	↘	
Trichloronitromethane (Chloropicrin)	→	↗	→	↘	→	↗	↗	↗	↗	↗	↗	↗	↗	↘	

# Materials

Fluid	NBR	EPDM	FKM	TPU	HNBR	CR	FMQ	MQ	IR	BR	IR	SBR	FFKM	ACM	PTFE
Trichlorophenylsilane													↑		
Trichloropropane	↓	↓	↑	↓	↓	↓	↓	↓	↓	↓	↓	↓	↑	↓	
Trichlorosilane	↓	↓	↑	↓	↓	↓	↓	↓	↓	↓	↓	↓	↑	↓	
Tricresyl Phosphate	↓	↗	↗	↓	↓	↓	↗	↗	↑	↓	↓	↗	↑	↓	↑
Triethanol Amine		↑		↓			↓	↗	↗	↗	↗	↑	↓	↓	↑
Triethyl Phosphate	↗	↓	↑	↗	↓	↓	↓	↓	↓	↓	↓	↓	↓	↓	
Triethylaluminum		↓	↗										↑		↑
Triethylborane			↑										↑		↑
Triethylene Glycol	↗	↑	↗	↓	↗	↑	↗	↑	↑	↑	↑	↑	↑	↓	
Triethylenetetramine	↗	↑	↗	↓	↗	↑	↗	↑	↑	↑	↑	↑	↑	↓	
Trifluoroacetic Acid	↗	↑	↗	↓	↗	↑	↗	↑	↑	↑	↑	↑	↗	↓	
Trifluoroethane	↓	↓	↑	↓	↓	↓	↓	↓	↓	↓	↓	↓	↑	↓	
Trifluoromethane (Fluoroform)	↓	↓	↑	↓	↓	↓	↓	↓	↓	↓	↓	↓	↑	↓	
Trifluorovinylchloride	↗	↓	↑	↗	↓	↓		↓	↓	↓	↓	↓	↑	↓	
Triisopropylbenzylchloride	↗	↓	↑	↗	↓	↓		↓	↓	↓	↓	↓	↑	↓	
Trimethylamine	↗	↑	↗	↓	↗	↑	↗	↑	↑	↑	↑	↑	↑	↓	
Trimethylamine (TMA)	↗	↑	↗	↓	↗	↑	↗	↑	↑	↑	↑	↑	↑	↓	
Trimethylbenzene	↗	↓	↑	↗	↓	↓		↓	↓	↓	↓	↓	↑	↓	
Trimethylborate (TMB)	↗	↓	↑	↗	↓	↓		↓	↓	↓	↓	↓	↑	↓	
Trimethylpentane	↑	↓	↑	↑	↑	↗	↑	↗	↓	↓	↓	↓	↑	↑	
Trinitrotoluene (TNT)	↓	↓	↗	↗	↓	↓		↓	↓	↓	↓	↓	↑	↓	↑
Trioctyl Phosphate	↓	↑	↗	↓	↓	↓	↗	↑	↓	↓	↓	↓	↑	↓	↑

Fluid	NBR	EPDM	FKM	TPU	HNBR	CR	FMQ	MQ	IR	BR	IR	SBR	FFKM	ACM	PTFE
Triphenylphosphite	↗	↑	↗	↓	↗	↑	↑	↗	↑	↑	↑	↑	↑	↓	
Tripoly Phosphate	↓	↑	↗	↓	↓	↗	↑	↗	↑	↓	↓	↓	↑	↓	
Tripotassium Phosphate	↗	↑	↗	↓	↗	↑	↑	↗	↑	↑	↑	↑	↑	↓	
Trisodium Phosphate	↗	↑	↗	↓	↗	↑	↑	↗	↑	↑	↑	↑	↑	↓	↑
Tung Oil (China Wood Oil)	↑	↓	↑	↗	↑	↗	↗	↓	↗	↓	↓	↓	↑		
Tungsten Hexafluoride													↗		
Tungstic Acid													↑		
Turbine Oil	↑	↓	↑	↑	↑	↓	↑	↓	↓	↓	↓	↓	↑	↑	
Turbine Oil #15 (MIL-L-7808A)	↗	↓	↑	↓	↗	↓	↓	↓	↓	↓	↓	↓	↑	↗	
Turbo Oil #35	↑	↓	↑	↑	↑	↗	↑	↓	↓	↓	↓	↓	↑	↑	
Turpentine	↑	↓	↑	↗	↑	↓	↗	↓	↓	↓	↓	↓	↑	↗	↑
Type I Fuel (MIL-S-3136) (ASTM Ref. Fuel A)	↑	↓	↑	↑	↑	↗	↑	↓	↓	↓	↓	↓	↑	↑	
Type II Fuel MIL-S-3136	↗	↓	↑	↗	↗	↓	↗	↓	↓	↓	↓	↓	↑	↗	
Type III Fuel MIL-S-3136 (ASTM Ref. Fuel B)	↗	↓	↑	↗	↗	↓	↗	↓	↓	↓	↓	↓	↑	↗	
Ucon Hydrolube J-4	↑	↑	↑	↓	↑	↗	↗	↑	↑	↗		↑	↑	↓	
Ucon Lubricant 50-HB-100	↑	↑	↑		↑	↑	↑	↑	↑	↑	↑	↑	↑		
Ucon Lubricant 50-HB-260	↑	↑	↑		↑	↑	↑	↑	↑	↑	↑	↑	↑		
Ucon Lubricant 50-HB-5100	↑	↑	↑		↑	↑	↑	↑	↑	↑	↑	↑	↑		
Ucon Lubricant 50-HB-660	↑	↑	↑		↑	↑	↑	↑	↑	↑	↑	↑	↑		
Ucon Lubricant 50-HB55	↑	↑	↑		↑	↑	↑	↑	↑	↑	↑	↑	↑		
Ucon Lubricant LB-1145	↑	↑	↑		↑	↑	↑	↑	↑	↑	↑	↑	↑		
Ucon Lubricant LB-135	↑	↑	↑		↑	↑	↑	↑	↑	↑	↑	↑	↑		

Fluid	NBR	EPDM	FKM	TPU	HNBR	CR	FMQ	MQ	IR	BR	IR	SBR	FFKM	ACM	PTFE
Ucon Lubricant LB-285	↑	↑	↑		↑	↑	↑	↑	↑	↑	↑	↑	↑		
Ucon Lubricant LB-300X	↑	↑	↑		↑	↑	↑	↑	↑	↑	↑	↑	↑		
Ucon Lubricant LB-625	↑	↑	↑		↑	↑	↑	↑	↑	↑	↑	↑	↑		
Ucon Lubricant LB-65	↑	↑	↑		↑	↑	↑	↑	↑	↗	↗	↗	↑		
Ucon Oil 50-HB-280x	↗	↑	↗		↗	↗							↑		
Ucon Oil Heat Transfer Fluid 500 (Polyalkalene Glycol)	↑	↑	↑		↑	↑	↑	↑	↑	↑	↑	↑	↑		
Ucon Oil LB-385	↑	↑	↑		↑	↑	↑	↑	↑	↑	↑	↑	↑		
Ucon Oil LB-400X	↑	↑	↑		↑	↑	↑	↑	↑	↑	↑	↑	↑		
Undecylenic Acid	↗	↓	↑	↗	↗	↓	↗		↓	↓	↓	↓	↑	↓	
Undecylic Acid	↗	↓	↑	↗	↗	↓	↗		↓	↓	↓	↓	↑	↓	
Univis 40 (Hydr. Fluid)	↑	↓	↑	↑	↑	↗	↑	↓	↓	↓	↓	↓	↑	↑	
Univolt #35 (Mineral Oil)	↑	↓	↑	↑	↑	↗	↑	↓	↓	↓	↓	↓	↑	↑	
Unsymmetrical Dimethyl Hydrazine (UDMH)	↗	↑	↓		↗	↗	↓	↓	↑	↑	↑	↗	↑		
UPDI(Ultrapur Deionized Water)	↗	↑	↗	↓	↗	↑	↑	↗	↑	↑	↑	↑	↑	↓	
Uranium Hexachloride			↑										↑		
Uric Acid	↗	↑	↗	↓	↗	↑	↑	↗	↑	↑	↑	↑	↑	↓	
Valeraldehyde	↗	↑	↗	↓	↗	↑	↑	↗	↑	↑	↑	↑	↑	↓	
Valeric Acid	↗	↑	↗	↓	↗	↑	↑	↗	↑	↑	↑	↑	↑	↓	
Vanadium Oxide	↑	↓	↑	↑	↑	↗	↑	↗	↓	↓	↓	↓	↑	↑	
Vanadium Pentoxide	↑	↓	↑	↑	↑	↗	↑	↗	↓	↓	↓	↓	↑	↑	
Varnish	↗	↓	↑	↗	↗	↓	↗	↓	↓	↓	↓	↓	↑	↓	
Vegetable Oil	↑	↓	↑		↑	↗	↑	↑	↗	↓	↓	↓	↑	↗	

# Materials

Fluid	NBR	EPDM	FKM	TPU	HNBR	CR	FMQ	MQ	IIR	BR	IR	SBR	FFKM	ACM	PTFE
Versilube F-50	↑	↑	↑	↑	↑	↑	↑	→	↑	↑	↑	↑	↑	↑	↑
Versilube F44, F55	↑	↑	↑	↑	↑	↑							↑		
Vinegar	↗	↑	↗	↓	↗	↗	→	→	↗	↗	↗	↗	↑	↓	
Vinyl Acetate	↗	↑	→		↗	↗							↑		↑
Vinyl Benzene	↗	↓	↑	↗	↓	↗			↓	↓	↓	↓	↑	↓	
Vinyl Benzoate	↗	↓	↑	→	↗	↓	↗		↓	↓	↓	↓	↑	↓	
Vinyl Chloride	↗	↓	↑	↗	↓	↗			↓	↓	↓	↓	↑	↓	↑
Vinyl Fluoride	↗	↓	↑	→	↗	↓	↗		↓	↓	↓	↓	↑	↓	
Vinylidene Chloride	↓	↓	↑	↓	↓	↓	↗		↓	↓	↓	↓	↑	↓	
Vinylpyridine	↗	↓	↑	→	↗	↓	↗		↓	↓	↓	↓	↑	↓	
Vitriol (White)	→	↑	→	↓	→	↑	↑	↗	↑	↑	↑	↑	↑	↓	
VV-H-910	→	↑	↑	↓	→	↗	↗	↗	↗	↗	↗	↑	↑	↗	
Wagner 21B Brake Fluid	→	↑	↓		→	↗	↓	→	↗			↑	↑		
Water	↑	↑	↗	↓	↗	↗	↑	↑	↑	↑	↑	↑	↑	↓	↑
Wemco C	↑	↓	↑	↑	↑	↗	↑	↓	↓	↓	↓	↓	↑	↑	
Whisky and Wines	↑	↑	↑	↓	↑	↑	↑	↑	↑	↑	↑	↑	↑	↓	↑

Fluid	NBR	EPDM	FKM	TPU	HNBR	CR	FMQ	MQ	IIR	BR	IR	SBR	FFKM	ACM	PTFE
White Liquor	↑	↑	↑		↑	↑							↑		↑
White Oil	↑	↓	↑	↑	↑	↗	↑	↓	↓	↓	↓	↓	↑	↑	↑
White Pine Oil	↗	↓	↑		↗	↓	↑	↓	↓	↓	↓	↓	↑		
Wolmar Salt	↑	↑	↑	↑	↑	↗	↑	↑	↑	↑	↑	↑	↑	↗	
Wood Oil	↑	↓	↑	→	↑	↗	↗	↓	→	↓	↓	↓	↑	↑	
Xenon	↑	↑	↑	↑	↑	↑	↑	↑	↑	↑	↑	↑	↑	↑	
Xylene	↓	↓	↗	↓	↓	↓	↑	↓	↓	↓	↓	↓	↑	↓	↑
Xylidenes-Mixed-Aromatic Amines	↓	↗	↓	↓	↓	↓	↓	↓	↓	↓	↓	↓	↑	↓	
Xylol	↓	↓	↑	↓	↓	↓	↑	↓	↓	↓	↓	↓	↑	↓	
Zeolites	↑	↑	↑		↑	↑	↑		↑	↑	↑	↑	↑		↑
Zinc Acetate	↗	↑	↓	↓	↗	↗	↓	↓	↑	↓	↑	↓	↑	↓	↑
Zinc Ammonium Chloride	→	↑	→	↓	→	↑	↑	↗	↑	↑	↑	↑	↑	↓	
Zinc Chloride	↑	↑	↑		↑	↑	↑		↑	↑	↑	↑	↑	↓	
Zinc Chromate	→	↑	→	↓	→	↑	↑	↗	↑	↑	↑	↑	↑	↓	
Zinc Cyanide	→	↑	→	↓	→	↑	↑	↗	↑	↑	↑	↑	↑	↓	
Zinc Diethyldithiocarbamate	→	↑	→	↓	→	↑	↑	↗	↑	↑	↑	↑	↑	↓	

Fluid	NBR	EPDM	FKM	TPU	HNBR	CR	FMQ	MQ	IIR	BR	IR	SBR	FFKM	ACM	PTFE
Zinc Dihydrogen Phosphate	→	↑	↑	↓	→	↑	↑	↗	↑	↑	↑	↑	↑	↓	
Zinc Fluorosilicate													↑		
Zinc Hydrosulfite	→	↑	→	↓	→	↑	↑	↗	↑	↑	↑	↑	↑	↓	
Zinc Naphthenate													↑		
Zinc Nitrate	↑	↑	↑		↑	↑	↑		↑	↑	↑	↑	↑	↓	
Zinc Oxide	↑	↑	↑		↑	↑	↑		↑	↑	↑	↑	↑	↓	
Zinc Phenolsulfonate	→	↑	→	↓	→	↑	↑	↗	↑	↑	↑	↑	↑	↓	
Zinc Phosphate	↑	↑	↑	↑	↑	↑	↑	↑	↑	↑	↑	↑	↑	↓	
Zinc Salts	↑	↑	↑	↑	↑	↑	↑	↑	↑	↑	↑	↑	↑	↓	
Zinc Silicofluoride													↑		
Zinc Stearate	→	↑	→	↓	→	↑	↑	↗	↑	↑	↑	↑	↑	↓	
Zinc Sulfate	↑	↑	↑	↓	↑	↑	↑	↑	↑	↗	↗	↗	↑	↓	
Zinc Sulfide	→	↑	→	↓	→	↑	↑	↗	↑	↑	↑	↑	↑	↓	
Zirconium Nitrate	↑	↑	↑	↓	↑	↑	↑	↑	↑	↗	↗	↗	↑	↓	



# Housing construction

## Gap widths

The limiting values for the gap at the non-pressurized side of the seal are determined by the pressure loading, by the type of the seal and by the material of the seal.

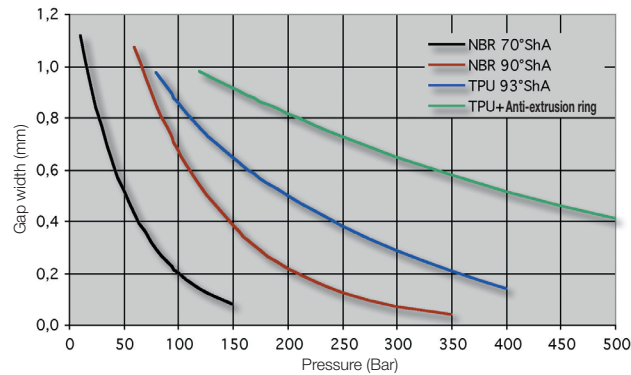

When calculating the gap widths, the given play at the guide (fitting tolerance) and the elastic stretching of the cylinder bore under pressure must be considered. Otherwise the permissible gap width will be exceeded with offset installation of the rod or piston. If the permissible gap widths are exceeded, then extrusion wear (see figure) occurs at the back of the seal and this destroys the seal after a short period of time.

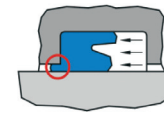

# Housing construction

## Surface texture

### General info

The texture of a surface against which a seal rubs has a significant effect on friction, wear and seal life. Texture in this context refers both to surface roughness and to the pattern of these irregularities. The former is capable of sampling measurement. Pattern can only be described empirically.

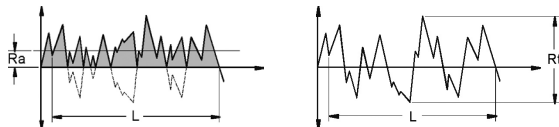

The standard method of measuring roughness is by an average value of the profile variation from a centre line over a reference length (L). This is known as Centre Line Average (CLA), now commonly expressed as Ra ( $\mu\text{m}$ ).

Surface roughness may also be expressed in terms of maximum roughness, depth or the distance between the peak and the base line measurement over the sampling length. Maximum roughness is designed Rt and is measured in the same units as Ra. Both values can be significant in determining the optimum surface finish required for use with seal.

### Recommended surface finishes

The aim of all types of surface finishing is to provide a surface which causes the least wear to the seal.

Rod seals, which seal against moving surfaces, can be damaged by fine abrasive particles which may adhere to a rough surface. Rods should, therefore, have a low surface roughness value, and a surface similar to the hard chrome and a resistance to corrosion. The ideal surface roughness lies somewhere around  $0.3 \mu\text{m}$  (Ra) or  $2.3 \mu\text{m}$  (Rt).

Piston seals, which seal against the inner surface of a cylinder, are not subjected to the same extent to the action of abrasive dirt particles entering from the atmosphere, and can, therefore, tolerate a rougher surface. The ideal surface roughness value lies around  $0.5 \mu\text{m}$  (Ra) or  $3.7 \mu\text{m}$  (Rt).

The operating pressure must also be taken into account when evaluating surface properties. At higher operating pressure, the oil film between the seal and the sealing surface is thinner, and the friction is greater. Under such conditions of operation a surface quality which approaches the lower values given should be chosen.

The surface in the seal housing, where the seal is static, should have a surface quality of about  $1 \mu\text{m}$  (Ra) or  $7 \mu\text{m}$  (Rt).

### Finishes from machining processes

Both the roughness and pattern of the surface finish produced can vary widely with different machining processes. The

following gives typical values likely achieved with different processes (but can also be variable depending on the quality of the machine tool and the material being processed).

As an example, optimum seal life with a hydraulic piston rod seal is given when the rod is circular ground (or roller burnished) to a surface finish of better than  $0.2 \mu\text{m}$  (Ra).

Process	Surface finish Ra [ $\mu\text{m}$ ]
Planing	1.5 ÷ 12.5
Shaping	1.5 ÷ 12.5
Milling	0.9 ÷ 6.25
Broaching	0.9 ÷ 3.00
Reaming	0.9 ÷ 3.00
Boring	0.5 ÷ 6.25
Turning	0.5 ÷ 6.25
Diamond bored and turned	0.25 ÷ 0.5
Grinding	0.125 ÷ 1.75
Honing	0.125 ÷ 1.625
Buffing, burnishing	0.125 ÷ 0.5
Lapping	0.05 ÷ 0.5
Polishing	0.05 ÷ 0.5
Super finishing	0.025 ÷ 0.25

- Roughness with the common metal work processes -

## Lead-in chamfer

It is very important to ensure rounded lead-in chamfers (see figure) without sharp edges and burrs to avoid damaging the sealing lips during the assembly of the cylinder components. However it is very difficult, during installation, to damage some resistant materials such as polyure-

thane, for instance.

In the tables of each item, the values recommended for depth and length of chamfers are shown. A reduction of that values may create assembly problems.

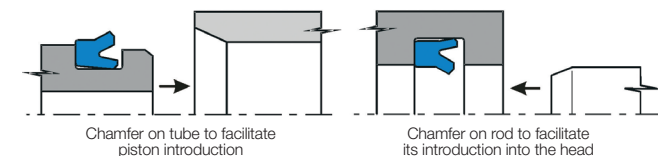

# Installation

## General assembly suggestions

The following are general rules for good installation valid for all types of seals:

- To avoid damaging the sealing lips during installation, housing must have rounded chamfers. Sharp edges and burrs within the installation area of the seal must be removed
- Check presence of lead-in chamfer and absence of sharp and cutting edges
- Lubricate both seal and sliding surfaces during assembly

bly with the same fluid as used in the hydraulic system, or with a compatible one

- Adhere to the tolerances and surface finishes stated in this catalogue to make the fitting of the seal easier and to avoid assembly damages
- All parts must be perfectly clean, without metal particles, welding splatter or any kind of defect
- During installation, avoid using pointed or sharp metal tools

- Check the correct orientation of the seal according to the fluid direction
- After assembly, it is advisable to test the cylinder because, during the first cycles, a leakage of a certain quantity of fluid could happen due to the settling of the seals
- To avoid permanent damage of the seals, after completing the cylinder assembly, don't exceed temperature of 80 °C during operations such as painting, heat curing, etc.

## Installation guidelines for rod seals

Usually rod seals can be assembled without using special tools. Rod seals with small diameter need the use of simple assembly tools that can facilitate the assembly. These tools, manufactured conveniently out of metal, should be adapted to the other equipment for the cylinder assembly.

The rod seals can also be easily placed into closed housing grooves deforming them by hand or with a special tool to obtain a ring similar to a kidney shape (see figure).

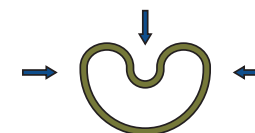

## Installation guidelines for piston seals

Usually piston seals can be assembled without using special tools. Piston seals with a large radial section in relation to the diameter should be slowly expanded and fitted with simple tools that can facilitate the assembly. These

tools, manufactured conveniently out of metal, should be adapted to the other equipment for the cylinder assembly (see figure). Pre-heating to 50-60 °C in hydraulic oil is advantageous.

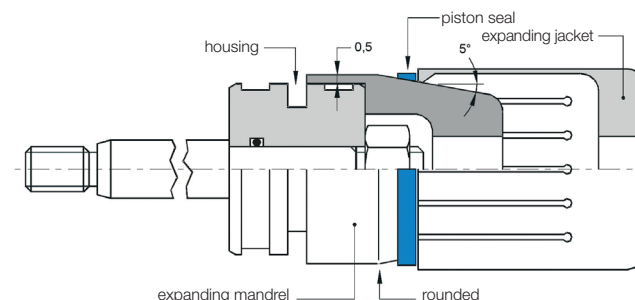

# Trouble shooting

Fault	Cause	Action
<b>High friction</b>	• improper assembly	• check against recommended assembly for that type of seal, reduce interference fit or pressure if necessary
	• wrong size of seal	• check geometric specification
	• poor surface finish	• improve surface finish or use a seal material capable of rubbing on a rougher surface
	• excessive rubbing speed	• different seal type may be required
<b>Stick-slip</b>	• excessive pressure being sealed	• replace seal with a different type, or with different type of elastomer
	• seal allowed to dry out	• -
	• poor surface finish	• improve surface finish or use a seal material capable of rubbing on a rougher surface
	• inadequate lubricating film	• amend operating conditions or change seal type (e.g. use PTFE composite seal)
<b>Excessive leakage</b>	• seal fitted wrong way round	• check - or use double-acting seal when required
	• insufficient pre-load	• check geometry and pre-load specification
	• seal shrinkage	• check that seal material is compatible with fluid; if not replace seal
	• seal wear	• replace seal; if life is low, consider an alternative seal type. Check for cause if seal is damaged
<b>Seal damage</b>	• incorrect initial assembly	• replace seal following manufacture's assembly instructions
	• spiral failure (applicable to O-Ring)	• check geometry; also suitability of O-Ring for the application
	• extrusion damage	• reduce extrusion gap in seal assembly; or incorporate back-up ring
	• rubbing	• check geometry; reduce extrusion gap if necessary

# General technical data

## Conversion Table

### LENGTH

	m	mm	µm	in	ft	mile
<b>m</b>	1	10 <sup>3</sup>	10 <sup>6</sup>	39,37	3,2808	6,21 · 10 <sup>-4</sup>
<b>mm</b>	10 <sup>-3</sup>	1	10 <sup>3</sup>	0,03937	0,0033	6,21 · 10 <sup>-7</sup>
<b>µm</b>	10 <sup>-6</sup>	10 <sup>-3</sup>	1	3,94 · 10 <sup>-5</sup>	3,28 · 10 <sup>-6</sup>	6,21 · 10 <sup>-10</sup>
<b>in</b>	0,0254	25,4	25400	1	0,0833	1,58 · 10 <sup>-5</sup>
<b>ft</b>	0,3048	304,8	304800	12	1	1,89 · 10 <sup>-4</sup>
<b>mile</b>	1609,3	1,61 · 10 <sup>6</sup>	1,61 · 10 <sup>9</sup>	63,35 · 10 <sup>3</sup>	5279,94	1

### PRESSURE

	Pa	Mpa	bar	Kgf/cm <sup>2</sup>	atm	psi
<b>Pa (N/m<sup>2</sup>)</b>	1	10 <sup>-6</sup>	10 <sup>-5</sup>	1,02 · 10 <sup>-5</sup>	9,87 · 10 <sup>-6</sup>	1,45 · 10 <sup>-4</sup>
<b>Mpa</b>	10 <sup>6</sup>	1	10	10,2	9,87	145,0377
<b>bar</b>	10 <sup>5</sup>	0,1	1	1,02	0,987	14,5038
<b>Kgf / cm<sup>2</sup></b>	9,81 · 10 <sup>4</sup>	9,81 · 10 <sup>-2</sup>	0,981	1	0,968	14,2233
<b>atm</b>	1,013 · 10 <sup>5</sup>	0,1013	1,013	1,033	1	14,6923
<b>psi</b>	6894,76	0,006895	0,06894	0,0703	0,06806	1

### SPEED

	m/s	m/min	km/h	ft/s	inches/s	mile/h
<b>m/s</b>	1	60	3,6	3,2808	39,37	2,2369
<b>m/min</b>	0,0167	1	0,06	0,0547	0,6562	0,03728
<b>km/h</b>	0,2778	16,6667	1	0,9113	10,9361	0,62137
<b>ft/s</b>	0,3048	18,2882	1,0973	1	12	0,68183
<b>inches/s</b>	0,0254	1,524	0,0914	0,0833	1	0,05682
<b>mile/h</b>	0,44704	26,8224	1,6093	1,4666	17,6	1

### VISCOSITY

	Pa · s	P	cP	St	cSt	m <sup>2</sup> /s
<b>Pa · s</b>	1	10	1000			
<b>P (poises)</b>	0,1	1	100			
<b>cP (centipoises)</b>	10 <sup>-3</sup>	0,01	1			
<b>St (stokes)</b>				1	100	10 <sup>-4</sup>
<b>cSt (centistokes)</b>				0,01	1	10 <sup>-6</sup>
<b>m<sup>2</sup>/s</b>				10 <sup>4</sup>	10 <sup>6</sup>	1

### ENERGY

	Btu	cal	foot poundal	Wh	kWh	erg
<b>Joule (Nm)</b>	9,47 · 10 <sup>-4</sup>	0,23866	23,7304	2,778 · 10 <sup>-4</sup>	2,778 · 10 <sup>-7</sup>	10 <sup>7</sup>

### POWER

	ft lb / h	ft lb / min	HP (metr)	Btu/h	HP (eletr)	erg/s
<b>Watt (Nm/s)</b>	2655,224	44,25372	1,36 · 10 <sup>-3</sup>	3,4121	1,34 · 10 <sup>-3</sup>	10 <sup>7</sup>

### FORCE

	N	Kg <sub>f</sub>	Libbra <sub>f</sub>
<b>N (kg m/s<sup>2</sup>)</b>	1	0,102	0,2248
<b>Kg<sub>f</sub></b>	9,81	1	2,2040
<b>lb<sub>f</sub></b>	4,4482	0,4537	1

### TEMPERATURE

	°C	°F	°K
<b>°C</b>	1	5/9 · (°F-32)	°K - 273,15
<b>°F</b>	9/5 · °C + 32	1	9/5 · °K - 459,67
<b>°K</b>	°C + 273,15	5/9 · °F + 255,37	1

# General technical data

## TOLERANCE CHART - ISO

Φ [mm]	Shafts [μm]								Bores [μm]							
	f7		f8		h8		h9		H8		H9		H10		H11	
1 ÷ 3	-6	-16	-6	-20	0	-14	0	-25	+14	0	+25	0	+40	0	+60	0
> 3 ÷ 6	-10	-22	-10	-28	0	-18	0	-30	+18	0	+30	0	+48	0	+75	0
> 6 ÷ 10	-13	-28	-13	-35	0	-22	0	-36	+22	0	+36	0	+58	0	+90	0
> 10 ÷ 18	-16	-34	-16	-43	0	-27	0	-43	+27	0	+43	0	+70	0	+110	0
> 18 ÷ 30	-20	-41	-20	-53	0	-33	0	-52	+33	0	+52	0	+84	0	+130	0
> 30 ÷ 50	-25	-50	-25	-64	0	-39	0	-62	+39	0	+62	0	+100	0	+160	0
> 50 ÷ 65	-30	-60	-30	-76	0	-46	0	-74	+46	0	+74	0	+120	0	+190	0
> 65 ÷ 80	-30	-60	-30	-76	0	-46	0	-74	+46	0	+74	0	+120	0	+190	0
> 80 ÷ 100	-36	-71	-36	-90	0	-54	0	-87	+54	0	+87	0	+140	0	+220	0
> 100 ÷ 120	-36	-71	-36	-90	0	-54	0	-87	+54	0	+87	0	+140	0	+220	0
> 120 ÷ 140	-43	-83	-43	-106	0	-63	0	-100	+63	0	+100	0	+160	0	+250	0
> 140 ÷ 160	-43	-83	-43	-106	0	-63	0	-100	+63	0	+100	0	+160	0	+250	0
> 160 ÷ 180	-43	-83	-43	-106	0	-63	0	-100	+63	0	+100	0	+160	0	+250	0
> 180 ÷ 200	-50	-96	-50	-122	0	-72	0	-115	+72	0	+115	0	+185	0	+290	0
> 200 ÷ 225	-50	-96	-50	-122	0	-72	0	-115	+72	0	+115	0	+185	0	+290	0
> 225 ÷ 250	-50	-96	-50	-122	0	-72	0	-115	+72	0	+115	0	+185	0	+290	0
> 250 ÷ 280	-56	-108	-56	-137	0	-81	0	-130	+81	0	+130	0	+210	0	+320	0
> 280 ÷ 315	-56	-108	-56	-137	0	-81	0	-130	+81	0	+130	0	+210	0	+320	0
> 315 ÷ 355	-62	-119	-62	-151	0	-89	0	-140	+89	0	+140	0	+230	0	+360	0
> 355 ÷ 400	-62	-119	-62	-151	0	-89	0	-140	+89	0	+140	0	+230	0	+360	0
> 400 ÷ 450	-68	-131	-68	-165	0	-97	0	-155	+97	0	+155	0	+250	0	+400	0
> 450 ÷ 500	-68	-131	-68	-165	0	-97	0	-155	+97	0	+155	0	+250	0	+400	0



# SA

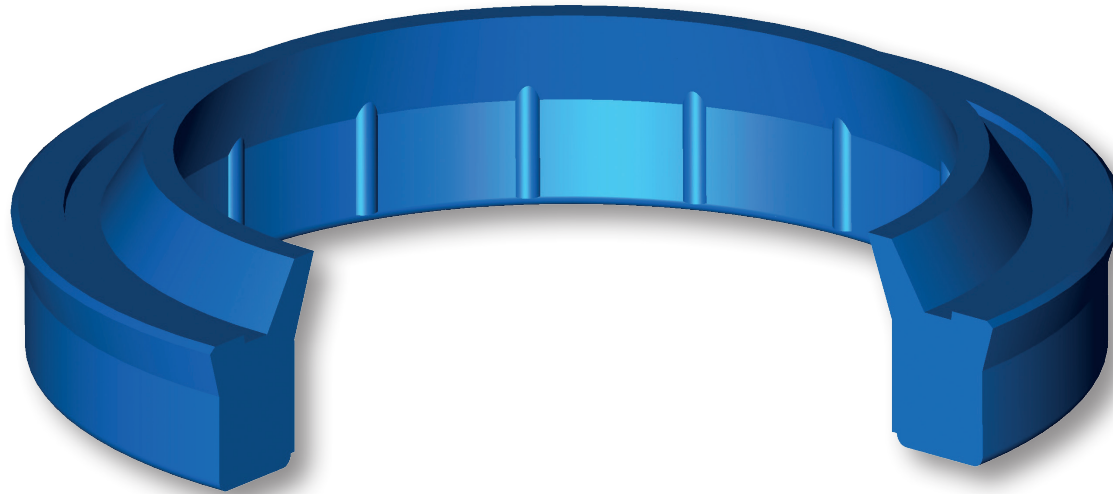

MATERIAL			
Type	Designation	Hardness	
Polyurethane	SEALPUR 93	93 °ShA	

### FIELD OF APPLICATION



**Fluids** Hydraulic oils (mineral oil based)  
For other fluids contact our technical department

### SURFACE ROUGHNESS

<b>Dynamic surface</b>	Suitable for rod seal system	
<b>Static surface</b>	Ra ≤ 1.6 µm	Rt ≤ 6.3 µm

### LEAD-IN CHAMFERS

d	Smin
less 100	5 mm
100÷200	7 mm
over 200	10 mm

Any pressure loads on the back of the rings should be avoided.  
Sharp edges and burrs within the installation area must be removed.

The above data are maximum values, they may be maintained for short periods and can not be used at the same time simultaneously.

The function of the Aston Seals SA wiper ring is to prevent introduction of dust, dirt and foreign matter into the system.

This is achieved by a special wiper lip which produces a very effective cleaning action, prevents the development of scores, protects the guiding parts and extends the service life of the axial moving rod seals.

An external sealing lip on the outside diameter contacts the housing in order to prevent moisture entering the groove.

The internal ribs give stability and prevent twisting and sticking of the wiper in the groove.

The material used to produce this wiper is a polyurethane compound that ensures

excellent properties in case of dry run, an increased wear-resistance and an extended service life due to good resistance against ozone and radiation caused by weather conditions.

- External sealing lip for a real housing protection
- Extended service life
- Low cost solution
- Excellent wear-resistance
- Space-saving construction
- No close tolerances are necessary
- Easy installation without expensive auxiliaries



# SA

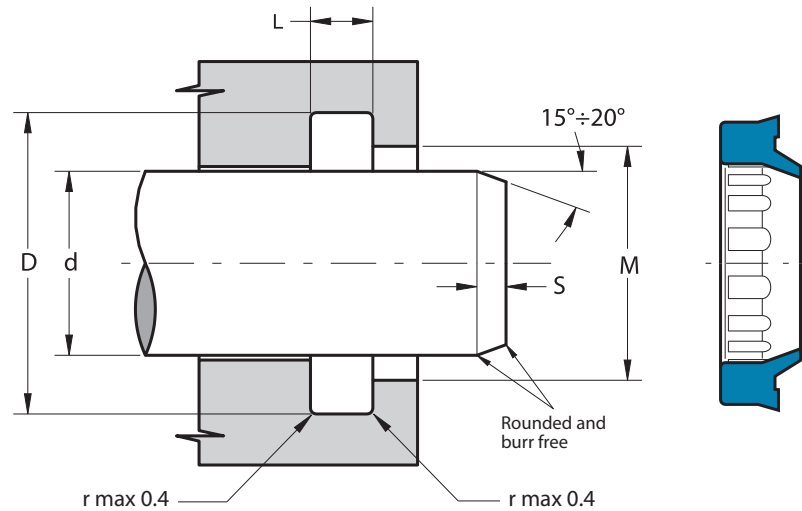

Part.	d <sup>f7</sup>	D <sup>H10</sup>	L <sup>+0.2</sup>	M <sup>+0.2</sup>
SA 4	4	12.0	3.0	9.0
SA 5/S	5	12.0	2.8	9.0
SA 6/S	6	12.0	3.0	9.0
SA 8	8	14.6	3.8	11.0
SA 9/S	9	13.0	2.5	12.0
SA 10	10	16.6	3.8	13.8
SA 10/S	10	15.0	1.0	13.0
SA 12	12	18.6	3.8	15.0
SA 13	13	19.6	3.8	16.0
SA 14	14	20.6	3.8	17.0
SA 15	15	21.6	3.8	18.0
SA 16	16	22.6	3.8	19.0
SA 16/A	16	22.5	3.0	19.0
SA 17	17	23.6	3.8	20.0
SA 18	18	24.6	3.8	21.0
SA 20	20	28.6	5.3	23.0
SA 20/A	20	26.0	3.4	23.0
SA 22	22	30.6	5.3	25.0
SA 22/A2	22	30.6	2.2	25.0
SA 24	24	32.6	5.3	27.0
SA 24/A2	24	32.6	2.2	27.0
SA 25	25	33.6	5.3	28.0
SA 25/H	25	32.5	1.6	27.9
SA 28	28	36.6	5.3	31.0

Part.	d <sup>f7</sup>	D <sup>H10</sup>	L <sup>+0.2</sup>	M <sup>+0.2</sup>
SA 30	30	38.6	5.3	33.0
SA 30/A2	30	40.0	3.0	34.5
SA 32	32	40.6	5.3	35.0
SA 32/H	32	39.5	1.6	34.9
SA 35	35	43.6	5.3	38.0
SA 35/A	35	43.6	5.0	38.0
SA 35/A2	35	45.0	4.0	39.0
SA 36	36	44.6	5.3	39.0
SA 36/A	36	44.0	5.3	39.0
SA 38	38	46.6	5.3	41.0
SA 40	40	48.6	5.3	43.0
SA 40/H	40	47.5	1.6	42.9
SA 42	42	50.6	5.3	45.0
SA 43.7/A	43.7	51.7	5.3	46.7
SA 45	45	53.6	5.3	48.0
SA 45/A	45	55.6	5.3	48.0
SA 45/A2	45	60.0	4.2	53.0
SA 48	48	56.6	5.3	51.0
SA 48/A	48	56.0	5.3	51.0
SA 50	50	58.6	5.3	53.0
SA 50/A	50	60.6	5.3	53.0
SA 50/A2	50	65.5	4.2	58.0
SA 52	52	60.6	5.3	55.0
SA 55	55	63.6	5.3	58.0

Part.	d <sup>f7</sup>	D <sup>H10</sup>	L <sup>+0.2</sup>	M <sup>+0.2</sup>
SA 55/A	55	65.6	5.3	58.0
SA 55/C	55	66.0	5.0	61.8
SA 56	56	64.6	5.3	59.0
SA 56/A	56	66.6	5.3	59.0
SA 60	60	68.6	5.3	63.0
SA 60/A	60	70.6	5.3	63.0
SA 60/S	60	70.6	5.5	66.0
SA 63	63	71.6	5.3	66.0
SA 63/A	63	73.6	5.3	66.0
SA 65	65	73.6	5.3	68.0
SA 65/A	65	75.6	5.3	68.0
SA 70	70	78.6	5.3	73.0
SA 70/A	70	82.6	7.1	76.0
SA 70/B	70	80.6	5.3	73.0
SA 70/D	70	76.0	5.3	72.0
SA 73/A	73	83.6	7.3	76.0
SA 75	75	83.6	5.3	78.0
SA 75/A	75	87.2	7.1	81.0
SA 78/A	78	90.0	7.5	83.0
SA 78/C	78	88.5	5.0	84.8
SA 78/S	78	88.6	5.5	84.0
SA 80	80	88.6	5.3	83.0
SA 80/A	80	92.6	7.1	86.0
SA 80/A2	80	90.0	2.15	84.6

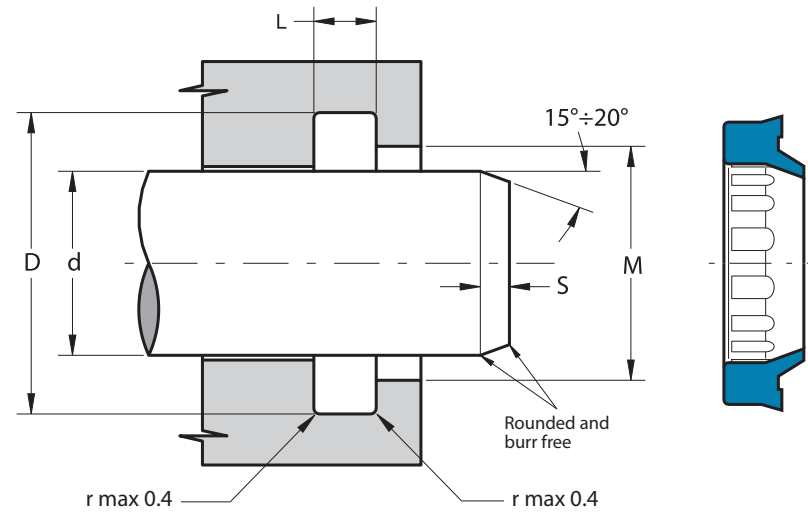

Part.	d <sup>f7</sup>	D <sup>H10</sup>	L <sup>+0.2</sup>	M <sup>+0.2</sup>
SA 85	85	97.2	7.1	91.0
SA 85/A	85	93.6	5.3	88.0
SA 90	90	102.2	7.1	96.0
SA 90/C	90	98.2	5.3	93.0
SA 90/D	90	98.6	5.3	93.0
SA 95	95	107.2	7.1	101.0
SA 99/S	99	109.6	5.5	105.0
SA 100	100	112.2	7.1	106.0
SA 105	105	117.2	7.1	111.0
SA 105/A	105	113.6	5.3	108.0
SA 105/C	105	116.0	5.0	111.8
SA 110	110	122.2	7.1	116.0
SA 115	115	127.2	7.1	121.0
SA 115/B	115	123.2	5.3	118.0
SA 120	120	132.2	7.1	126.0
SA 120/A	120	128.6	5.3	123.0
SA 120/S	120	130.6	5.5	126.0
SA 125	125	137.2	7.1	131.0
SA 125/A	125	140.2	10.1	132.6
SA 130	130	142.2	7.1	136.0
SA 135	135	147.2	7.1	141.0
SA 140	140	152.2	7.1	146.0
SA 140/A	140	148.6	5.3	143.0
SA 141/S	141	151.6	5.5	147.0

Part.	d <sup>f7</sup>	D <sup>H10</sup>	L <sup>+0.2</sup>	M <sup>+0.2</sup>
SA 145	145	157.2	7.1	151.0
SA 150	150	162.2	7.1	156.0
SA 150/B	150	158.2	5.3	153.0
SA 155	155	169.2	7.1	162.0
SA 160	160	175.2	10.1	168.0
SA 162/S	162	172.6	5.5	168.0
SA 170	170	185.2	10.1	178.0
SA 180	180	195.2	10.1	188.0
SA 183/S	183	193.6	5.5	189.0
SA 190	190	205.2	10.1	198.0
SA 190/A	190	210.0	10.1	200.0
SA 200	200	215.2	10.1	208.0
SA 207/S	207	217.6	5.5	213.0
SA 210	210	225.2	10.1	218.0
SA 220	220	235.2	10.1	228.0
SA 230	230	245.2	10.1	238.0
SA 240	240	255.2	10.1	248.0
SA 245	245	260.2	10.1	253.0
SA 250	250	265.2	10.1	258.0

Inch sizes

SA 1500 1875	38.1	47.6	4.75	42.1
--------------	------	------	------	------



# SAF



SAF

## MATERIAL

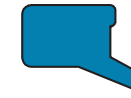

<b>Type</b>	<b>Designation</b>	<b>Hardness</b>
Polyurethane	SEALPUR 93	93 °ShA

## FIELD OF APPLICATION



**Fluids** Hydraulic oils (mineral oil based)  
For other fluids contact our technical department

## SURFACE ROUGHNESS

<b>Dynamic surface</b>	Suitable for rod seal system	
<b>Static surface</b>	Ra ≤ 1.6 μm	Rt ≤ 6.3 μm

## LEAD-IN CHAMFERS

d	Smin
less 100	5 mm
100÷200	7 mm
over 200	10 mm

Any pressure loads on the back of the rings should be avoided.  
Sharp edges and burrs within the installation area must be removed.

The above data are maximum values, they may be maintained for short periods and can not be used at the same time simultaneously.

The function of the Aston Seals SAF wiper ring is to prevent introduction of dust, dirt and foreign matter into the system.

This is achieved by a special wiper lip which produces a very effective cleaning action, prevents the development of scores, protects the guiding parts and extends the service life of the axial moving rod seals.

The material used to produce this wiper is a polyurethane compound that ensures excellent properties in case of dry run, an increased wear-resistance and an extended service life due to good resistance against ozone and radiation caused by weather conditions.

- Extended service life
- Low cost solution
- Excellent wear-resistance
- Space-saving construction
- No close tolerances are necessary
- Easy installation without expensive auxiliaries

# SAF

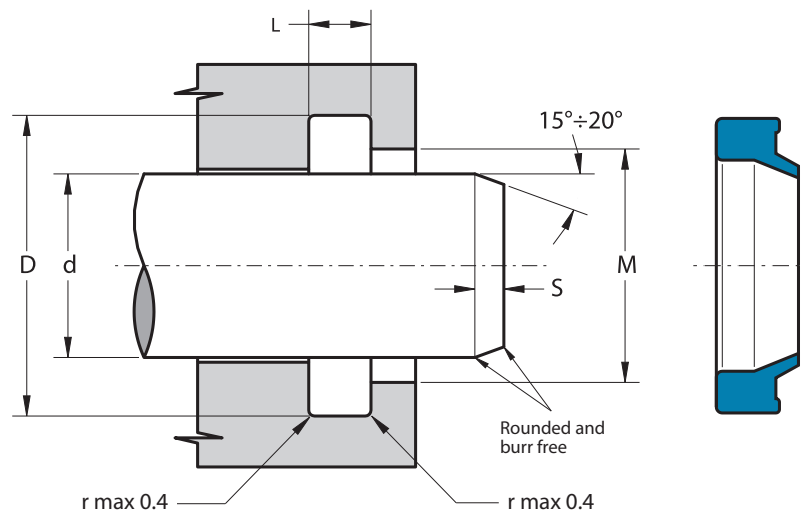

Part.	d <sup>f7</sup>	D <sup>H10</sup>	L <sup>+0.2</sup>	M <sup>+0.2</sup>
SAF 8	8	14.6	3.8	11.0
SAF 12/A	12	17.0	2.9	15.0
SAF 14	14	20.6	3.8	17.0
SAF 15	15	21.6	3.8	18.0
SAF 16	16	22.6	3.8	19.0
SAF 16/C	16	25.0	4.5	19.0
SAF 16/D	16	21.0	3.8	19.0
SAF 18	18	24.6	3.8	21.0
SAF 20	20	28.6	5.3	23.0
SAF 20/B	20	29.0	3.5	23.0
SAF 20/C	20	29.0	4.5	23.0
SAF 20/T	20	28.6	5.2	23.0
SAF 22/A	22	31.0	4.5	25.0
SAF 22/B	22	27.0	3.0	24.5
SAF 22/T	22	30.6	5.2	25.0
SAF 25	25	33.6	5.3	28.0
SAF 25/A	25	34.2	4.5	28.2
SAF 25/S	25	33.6	5.0	28.0
SAF 25/T	25	33.6	5.2	28.0
SAF 28	28	36.6	5.3	31.0
SAF 28/A	28	33.6	3.2	30.6
SAF 28/T	28	36.6	5.2	31.0
SAF 30	30	38.6	5.3	33.0
SAF 30/B	30	42.0	3.2	34.4

Part.	d <sup>f7</sup>	D <sup>H10</sup>	L <sup>+0.2</sup>	M <sup>+0.2</sup>
SAF 30/C	30	39.2	4.5	33.2
SAF 30/T	30	38.6	5.2	33.0
SAF 32	32	40.6	5.3	35.0
SAF 32/T	32	40.6	5.2	35.0
SAF 35	35	43.6	5.3	38.0
SAF 35/B	35	43.9	6.3	38.0
SAF 35/T	35	43.6	5.2	38.0
SAF 36	36	44.6	5.3	39.0
SAF 38/T	38	46.6	5.2	41.0
SAF 40	40	48.6	5.3	43.0
SAF 40/A	40	52.0	3.2	45.0
SAF 40/T	40	48.6	5.2	43.0
SAF 42	42	50.6	5.3	45.0
SAF 45	45	53.6	5.3	48.0
SAF 45/A/T	45	55.6	5.2	48.0
SAF 45/B	45	56.0	3.5	50.0
SAF 48/A/T	48	60.6	5.2	54.0
SAF 50	50	58.6	5.3	53.0
SAF 50/A/T	50	60.6	5.2	53.0
SAF 50/B	50	58.6	6.3	53.0
SAF 55	55	63.6	5.3	58.0
SAF 55/A/T	55	65.6	5.2	58.0
SAF 55/B	55	63.6	4.3	58.0
SAF 60	60	68.6	5.3	63.0

Part.	d <sup>f7</sup>	D <sup>H10</sup>	L <sup>+0.2</sup>	M <sup>+0.2</sup>
SAF 60/A/T	60	70.6	5.2	63.0
SAF 63/A/T	63	73.6	5.2	66.0
SAF 63/B	63	73.0	6.3	70.0
SAF 65	65	73.6	5.3	68.0
SAF 65/A/T	65	75.6	5.2	68.0
SAF 65/B	65	72.6	2.3	68.0
SAF 65/C	65	77.0	3.2	70.0
SAF 65/D	65	77.6	7.3	70.0
SAF 70	70	78.6	5.3	73.0
SAF 70/B/T	70	80.6	5.2	73.0
SAF 70/C	70	78.6	6.3	73.0
SAF 75/T	75	83.6	5.2	78.0
SAF 78/B	78	86.0	5.0	81.0
SAF 80/A/T	80	92.2	7.0	86.0
SAF 97/A/T	97	105.6	5.2	100.0
SAF 110	110	122.2	7.1	116.0
SAF 111/A	111	126.0	6.8	118.0
SAF 118/B	118	126.0	5.0	121.0
SAF 124/A	124	139.0	6.8	131.0
SAF 135/A	135	150.0	9.5	145.0
SAF 140/B	140	155.0	6.8	147.0
SAF 142/A	142	151.6	5.3	146.0
SAF 142/B	142	153.6	6.3	147.0
SAF 143/B	143	151.0	5.5	146.0

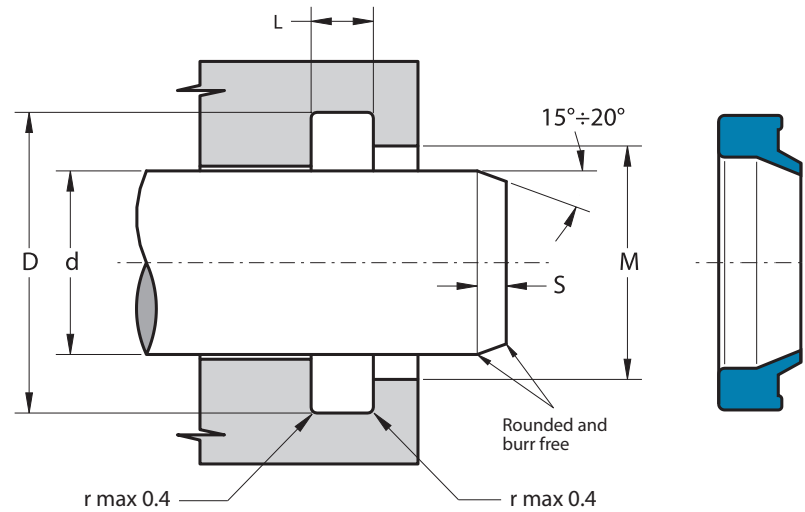

Part.	$d^{f7}$	$D^{H10}$	$L^{+0.2}$	$M^{+0.2}$
<b>SAF 145/B</b>	145	160.0	9.5	155.0
<b>SAF 150/C</b>	150	165.0	9.5	160.0
<b>SAF 155/A</b>	155	170.0	6.8	162.0
<b>SAF 160/A</b>	160	175.0	9.5	170.0
<b>SAF 170/A</b>	170	185.0	6.8	177.0
<b>SAF 186/A</b>	186	201.0	6.8	193.0
<b>SAF 200/A</b>	200	215.0	9.5	210.0
<b>SAF 216/A</b>	216	231.0	6.8	223.0

Inch sizes

<b>SAF 1000</b>	25.4	33.02	4.1	28.4
<b>SAF 3000</b>	76.2	88.9	6.3	83.9
<b>SAF 6500</b>	165.1	190.5	12.7	182.9
<b>SAF 7000</b>	177.8	203.2	12.7	195.6



# SAP



SAP

## MATERIAL



<b>Type</b>	<b>Designation</b>	<b>Hardness</b>
Thermoplastic polyester resin	SEALITE 55	55 °ShD

## FIELD OF APPLICATION



**Fluids** Hydraulic oils (mineral oil based)  
For other fluids contact our technical department

## SURFACE ROUGHNESS

<b>Dynamic surface</b>	Suitable for rod seal system
<b>Static surface</b>	Ra ≤ 1.6 µm      Rt ≤ 6.3 µm

## LEAD-IN CHAMFERS

d	Smin
less 100	5 mm
100÷200	7 mm
over 200	10 mm

Any pressure loads on the back of the rings should be avoided.  
Sharp edges and burrs within the installation area must be removed.

The above data are maximum values, they may be maintained for short periods and can not be used at the same time simultaneously.

The function of the Aston Seals SAP wiper ring is to prevent introduction of dust, dirt, foreign matter and heavily deposited ice and mud into the system.

This is achieved by a special wiper lip which produces a very effective cleaning action, prevents the development of scores, protects the guiding parts and extends the service life of the axial moving rod seals.

An external sealing lip on the outside diameter contacts the housing in order to prevent moisture entering the groove.

The internal ribs give stability, back pumping ability and prevent sticking of the wiper in the groove.

The material used to produce this wiper is a spe-

cial polyester resin that ensures excellent properties in case of heavy applications, an increased wear-resistance and an extended service life.

- External sealing lip for a real housing protection
- Suitable for heavy applications
- Back pumping ability
- Extended service life
- Low cost solution
- Excellent wear-resistance
- Space-saving construction
- Easy installation without expensive auxiliaries



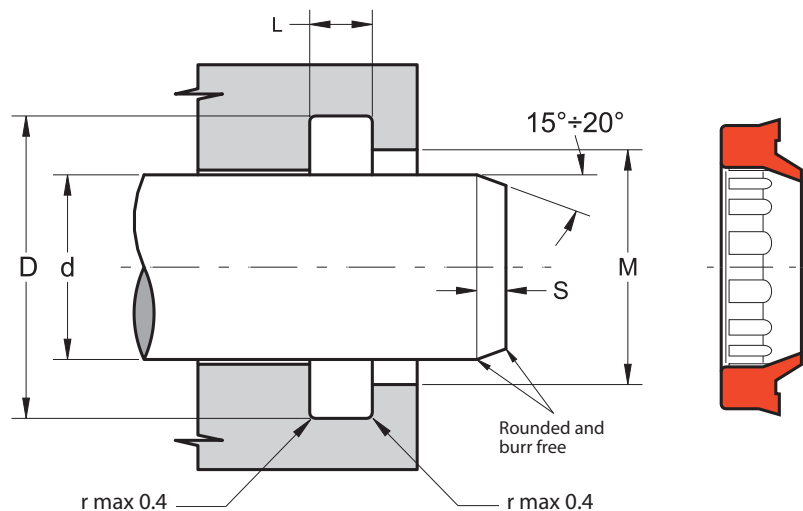

Part.	d <sup>f7</sup>	D <sup>H10</sup>	L <sup>+0.2</sup>	M <sup>+0.2</sup>
SAP 20 28 5	20	28.0	5.0	25.5
SAP 22 30 5	22	30.0	5.0	27.5
SAP 25 33 5	25	33.0	5.0	30.5
SAP 28 36 5	28	36.0	5.0	33.5
SAP 30 38 5	30	38.0	5.0	35.5
SAP 32 40 5	32	40.0	5.0	37.5
SAP 35 43 5	35	43.0	5.0	40.5
SAP 36 44 5	36	44.0	5.0	41.5
SAP 40 48 5	40	48.0	5.0	45.5
SAP 45 53 5	45	53.0	5.0	50.5
SAP 45 55.6 5.3	45	55.6	5.3	48.0
SAP 50 58 5	50	58.0	5.0	55.5
SAP 50 60.6 5.3	50	60.6	5.3	53.0
SAP 55 65 5.3	55	65.0	5.3	61.0
SAP 55 65 6.3	55	65.0	6.3	61.0
SAP 56 66 6.3	56	66.0	6.3	63.0
SAP 60 70 5.3	60	70.0	5.3	66.0
SAP 60 70 6.3	60	70.0	6.3	67.0
SAP 63 73 6.3	63	73.0	6.3	70.0
SAP 63 73.6 5.3	63	73.6	5.3	66.0

Part.	d <sup>f7</sup>	D <sup>H10</sup>	L <sup>+0.2</sup>	M <sup>+0.2</sup>
SAP 65 75 5.3	65	75.0	5.3	68.0
SAP 70 78 5	70	78.0	5.0	75.5
SAP 70 80 6.3	70	80.0	6.3	77.0
SAP 70 80.6 5.3	70	80.6	5.3	73.0
SAP 70 82.2 7.2	70	82.2	7.2	76.0
SAP 80 90 6.3	80	90.0	6.3	87.0
SAP 90 100 6.3	90	100.0	6.3	97.0
SAP 90 102.2 7.1	90	102.2	7.1	96.0
SAP 100 110.6 5.3	100	110.6	5.3	104.0
SAP 100 112.2 7.1	100	112.2	7.1	106.0
SAP 100 115 9.5	100	115.0	9.5	110.0
SAP 110 122.2 7.1	110	122.2	7.1	116.0

Inch sizes

SAP 1250 1625 0187	31.75	41.28	4.75	37.97
SAP 1500 1875 0187	38.10	47.63	4.75	44.32
SAP 1750 2125 0187	44.45	53.98	4.75	50.67
SAP 2000 2500 0250	50.80	63.50	6.35	59.10

# SAG



SAG

The function of the Aston Seals SAG wiper ring is to prevent introduction of dust, dirt and foreign matter into the system.

This is achieved by a special wiper lip which produces a very effective cleaning action, prevents the development of scores, protects the guiding parts and extends the service life of the axial moving rod seals.

A flush fitting with the outside diameter reduces moisture entering the groove.

The internal ribs give stability and prevent twisting and sticking of the wiper in the groove.

The material used to produce this wiper is a polyurethane compound that ensures excel-

lent properties in case of dry run, an increased wear-resistance and an extended service life due to good resistance against ozone and radiation caused by weather conditions.

- Extended service life
- External flush fitting for a good housing protection
- Low cost solution
- Excellent wear-resistance
- Space-saving construction
- No close tolerances are necessary
- Easy installation without expensive auxiliaries

## MATERIAL



Type	Designation	Hardness
Polyurethane	SEALPUR 93	93 °ShA

## FIELD OF APPLICATION



**Fluids** Hydraulic oils (mineral oil based)  
For other fluids contact our technical department

## SURFACE ROUGHNESS

<b>Dynamic surface</b>	Suitable for rod seal system
<b>Static surface</b>	Ra $\leq 1.6 \mu\text{m}$ Rt $\leq 6.3 \mu\text{m}$

## LEAD-IN CHAMFERS

d	Smin
less 100	5 mm
100÷200	7 mm
over 200	10 mm

Any pressure loads on the back of the rings should be avoided. Sharp edges and burrs within the installation area must be removed. The above data are maximum values, they may be maintained for short periods and can not be used at the same time simultaneously.

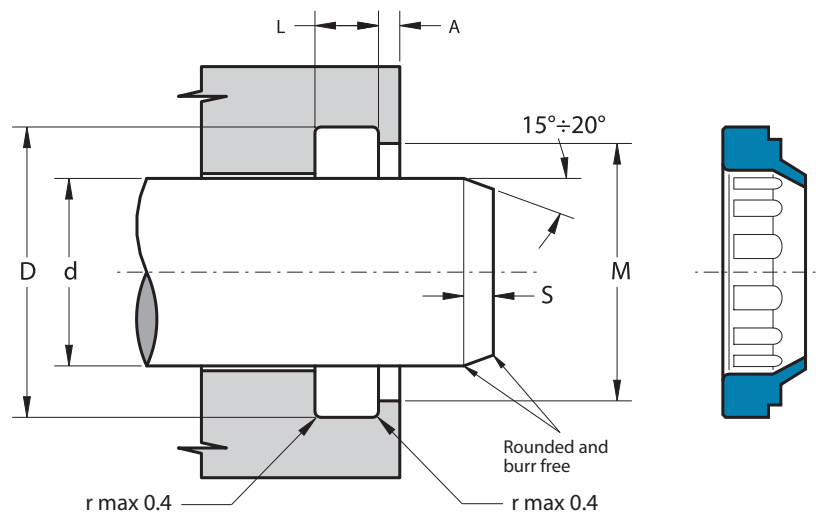

Part.	d <sup>f7</sup>	D <sup>±0.1</sup>	L <sup>+0.15</sup>	M <sup>H11</sup>	A <sup>±0.1</sup>
SAG 6	6	10	2	9	1
SAG 7	7	11	2	10	1
SAG 10/A	10	16	2.6	14	1
SAG 12	12	20	4	18	1
SAG 14/A	14	20	2.6	18	1
SAG 16	16	24	4	22	1
SAG 16/A	16	20.7	3.7	19	0.8
SAG 16/B	16	20.7	2.2	19	0.8
SAG 18	18	26	4	24	1
SAG 20	20	28	4	26	1
SAG 22	22	30	4	28	1
SAG 24	24	32	4	30	1
SAG 25	25	33	4	31	1
SAG 25/A	25	33.6	5.5	31.4	4
SAG 25/B	25	31	2.4	29	1
SAG 28	28	36	4	34	1
SAG 30	30	38	4	36	1
SAG 30/A	30	36	4	34	1
SAG 30/B	30	47.5	3	45.5	1.5
SAG 32	32	40	4	38	1
SAG 35	35	43	4	41	1
SAG 36	36	44	4	42	1
SAG 38	38	46	4	44	1
SAG 40	40	48	4	46	1

Part.	d <sup>f7</sup>	D <sup>±0.1</sup>	L <sup>+0.15</sup>	M <sup>H11</sup>	A <sup>±0.1</sup>
SAG 42	42	50	4	48	1
SAG 45	45	53	4	51	1
SAG 50	50	58	4	56	1
SAG 54	54	62	4	60	1
SAG 55	55	63	4	61	1
SAG 56	56	64	4	62	1
SAG 60	60	68	4	66	1
SAG 63	63	71	4	69	1
SAG 65	65	73	4	71	1
SAG 70	70	78	4	76	1
SAG 75	75	83	4	81	1
SAG 80	80	88	4	86	1
SAG 85	85	93	4	91	1
SAG 90	90	98	4	96	1
SAG 90/A	90	100	5.5	96	2
SAG 97/B	97	107	7	103	2
SAG 100	100	108	4	106	1
SAG 100/A	100	108	6	103.5	2
SAG 110	110	122	5.5	119	1.5
SAG 110/A	110	120	5.5	116	2
SAG 110/B	110	118	4	116	1
SAG 118/B	118	128	7	124	2
SAG 120	120	132	5.5	129	1.5
SAG 120/A	120	132	8.2	125	2.5

Part.	d <sup>f7</sup>	D <sup>±0.1</sup>	L <sup>+0.15</sup>	M <sup>H11</sup>	A <sup>±0.1</sup>
SAG 132/A	132	142	5.5	138	2
SAG 137/A	137	147	5.5	143	2
SAG 140/A	140	152	8.2	145	2.5
SAG 140/B	140	150	7	146	2
SAG 152/A	152	162	5.5	158	2
SAG 172/A	172	182	5.5	178	2
SAG 194/A	194	204	5.5	200	2

Inch sizes

SAG 3000	76.2	86.2	3.1	82.5	1.9
----------	------	------	-----	------	-----

# SAC



SAC

The function of the Aston Seals SAC wiper ring is to prevent introduction of dust, dirt and foreign matter into the system, to protect the guiding parts and to extend the service life of the axial moving rod seals.

This is achieved by:

- a special wiper lip which produces a very effective cleaning action and prevents the development of scores.
- an external flap which covers the gland housing, preventing the slurry retention and the ingress of contamination around the outside, as happens in traditional wipers.
- An additional external sealing lip on the outside diameter as a further protection against moisture entering the groove.

The internal ribs give stability, prevent twisting and sticking of the wiper in the groove as well as release back-pressure between the rod seal and the wiper.

The material used to produce this wiper is a polyurethane compound that ensures excellent properties in case of dry run, an increased wear-resistance and an extended service life due to good resistance against ozone and radiation caused by weather conditions.

- External flap for a absolute protection against moisture entering the groove
- Suitable for hard and heavy environments
- Particularly suitable for vertical cylinders
- Extended service life
- Back pumping ability
- Excellent wear-resistance
- Space-saving construction
- Easy installation without expensive auxiliaries

## MATERIAL



<b>Type</b>	<b>Designation</b>	<b>Hardness</b>
Polyurethane	SEALPUR 93	93 °ShA

## FIELD OF APPLICATION



**Fluids** Hydraulic oils (mineral oil based)  
For other fluids contact our technical department

## SURFACE ROUGHNESS

<b>Dynamic surface</b>	Suitable for rod seal system
<b>Static surface</b>	Ra ≤ 1.6 µm      Rt ≤ 6.3 µm

## LEAD-IN CHAMFERS

d	Smin
less 100	5 mm
100÷200	7 mm
over 200	10 mm

Any pressure loads on the back of the rings should be avoided.  
Sharp edges and burrs within the installation area must be removed.

The above data are maximum values, they may be maintained for short periods and can not be used at the same time simultaneously.

# SAC

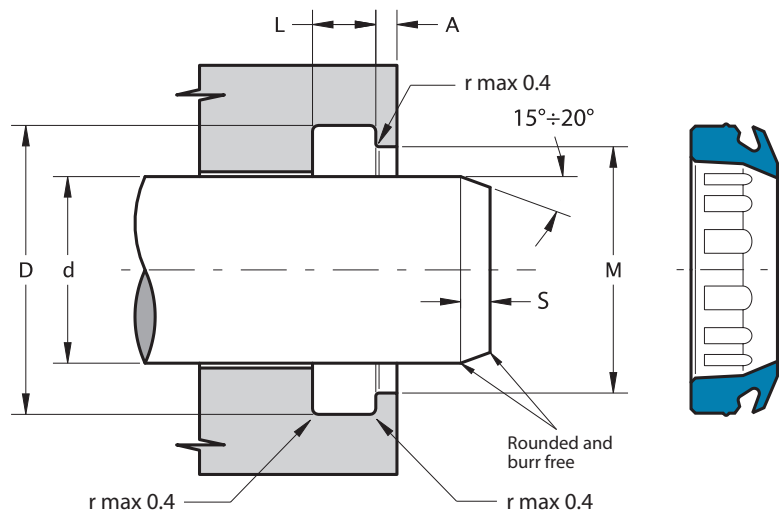

Part.	d <sup>f7</sup>	D <sup>H10</sup>	L <sup>+0.2</sup>	M <sup>H11</sup>	A <sup>+0.1</sup>
<b>SAC 35 45 6.3</b>	35	45.0	6.3	42.0	1.5
<b>SAC 36 44 5</b>	36	44.0	5.0	41.5	1.5
<b>SAC 40 48 5</b>	40	48.0	5.0	45.5	1.5
<b>SAC 45 53 5</b>	45	53.0	5.0	50.5	1.5
<b>SAC 50 58 5</b>	50	58.0	5.0	55.5	1.5
<b>SAC 56 66 6.3</b>	56	66.0	6.3	63.0	1.5
<b>SAC 60 70 6.3</b>	60	70.0	6.3	67.0	1.5
<b>SAC 63 73 6.3</b>	63	73.0	6.3	70.0	1.5
<b>SAC 70 82.6 8</b>	70	82.6	8.0	78.4	2.0
<b>SAC 80 90 6.3</b>	80	90.0	6.3	87.0	1.5
<b>SAC 90 102.2 7.1</b>	90	102.2	7.1	96.0	2.8

# SAW



SAW

## MATERIAL



<b>Type</b>	<b>Designation</b>	<b>Hardness</b>
Thermoplastic polyester resin	SEALITE 63	63 °ShD

## FIELD OF APPLICATION



**Fluids** Hydraulic oils (mineral oil based)  
For other fluids contact our technical department

## SURFACE ROUGHNESS

<b>Dynamic surface</b>	Suitable for rod seal system	
<b>Static surface</b>	Ra ≤ 1.6 μm	Rt ≤ 6.3 μm

## LEAD-IN CHAMFERS

d	Smin
less 100	5 mm
100÷200	7 mm
over 200	10 mm

Any pressure loads on the back of the rings should be avoided. Sharp edges and burrs within the installation area must be removed.

The above data are maximum values, they may be maintained for short periods and can not be used at the same time simultaneously.

The function of the Aston Seals SAW wiper ring is to prevent introduction of dust, dirt, foreign matter and heavily deposited ice and mud into the system.

This is achieved by a special wiper lip which produces a very effective cleaning action, prevents the development of scores, protects the guiding parts and extends the service life of the axial moving rod seals.

This type of wiper is designed to snap fit into its housing. To work properly it is important that its assembly is done with care.

The material used to produce this wiper is a special polyester resin that ensures excellent properties in case heavy applications, an

increased wear-resistance and an extended service life.

- Designed to snap fit into its housing
- Suitable for medium-heavy applications
- Extended service life
- Low cost solution
- Excellent wear-resistance
- Space-saving construction
- Easy installation without expensive auxiliaries

# SAW

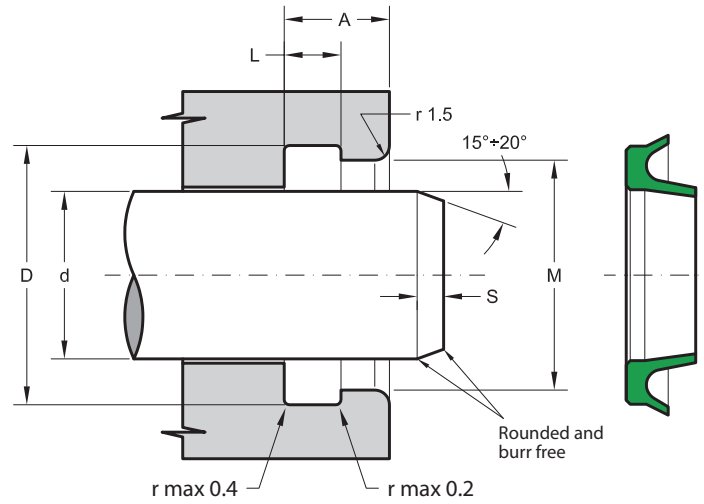

Part.	d <sup>f7</sup>	D <sup>H10</sup>	L <sup>+0.2</sup>	A	M <sup>-0.2</sup>
SAW 16	16	26.0	4.5	6.5	24.5
SAW 18	18	28.0	4.5	6.5	26.5
SAW 20	20	33.0	6.0	8.5	31.5
SAW 22	22	35.0	6.0	8.5	33.5
SAW 25	25	38.0	6.0	8.5	36.5
SAW 28	28	41.0	6.0	8.5	39.5
SAW 30	30	43.0	6.0	8.5	41.5
SAW 32	32	45.0	6.0	8.5	43.5
SAW 36	36	49.0	6.0	8.5	47.5
SAW 40	40	53.0	6.0	8.5	51.5
SAW 45	45	58.0	6.0	8.5	56.5
SAW 50	50	63.0	6.0	8.5	61.5
SAW 55	55	68.0	6.0	8.5	66.5
SAW 56	56	69.0	6.0	8.5	67.5
SAW 60	60	73.0	6.0	8.5	71.5
SAW 63	63	76.0	6.0	8.5	74.5
SAW 65	65	78.0	6.0	8.5	76.5
SAW 70	70	83.0	6.0	8.5	81.5
SAW 80	80	93.0	6.0	8.5	91.5
SAW 90	90	103.0	6.0	8.5	101.5
SAW 100	100	113.0	6.0	8.5	111.5

# SAB



SAB

## MATERIAL



Type	Designation	Hardness
Polyurethane	SEALPUR 93	93 °ShA

## FIELD OF APPLICATION

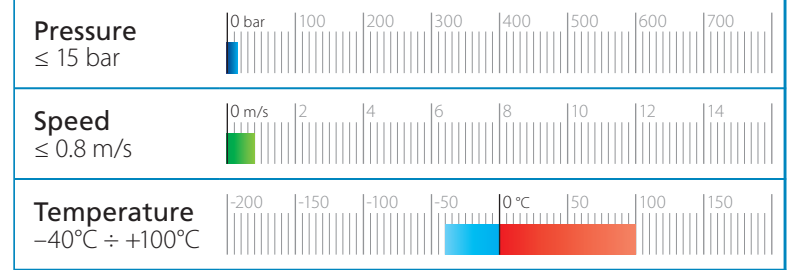

**Fluids** Hydraulic oils (mineral oil based)  
For other fluids contact our technical department

## SURFACE ROUGHNESS

<b>Dynamic surface</b>	Ra ≤ 0.3 µm	Rt ≤ 2.5 µm
<b>Static surface</b>	Ra ≤ 1.6 µm	Rt ≤ 6.3 µm

## LEAD-IN CHAMFERS

d	Smin
less 100	5 mm
100÷200	7 mm
over 200	10 mm

To avoid damaging the sealing lips during installation, housing must have rounded chamfers. Sharp edges and burrs within the installation area of the seal must be removed.

The above data are maximum values, they may be maintained for short periods and can not be used at the same time simultaneously.

The functions of the Aston Seals SAB bi-directional rod wiper are:

- to prevent introduction of dust, dirt and foreign matter into the system; this is achieved by a special wiper lip which produces a very effective cleaning action, prevents the development of scores, protects the guiding parts and extends the service life of the axial moving rod seals.
- to retain residual oil film on the rod; the asymmetric lips are designed to differentiate the behaviour of the lips on the static and dynamic surfaces: the static lips are flexible and more sensitive to pressure fluctuations; the dynamic lip is shorter and stronger to concentrate load against the dynamic surface.

The material used to produce this wiper is a polyurethane compound that ensures excellent properties in case of dry run, an increased wear-resistance and an extended service life due to good resistance against ozone and radiation caused by weather conditions.

- Retaining residual oil film
- Extended service life
- Insensitive to structural deflections
- Excellent wear-resistance
- Space-saving construction
- No close tolerances are necessary
- Easy installation without expensive auxiliaries



# SAB

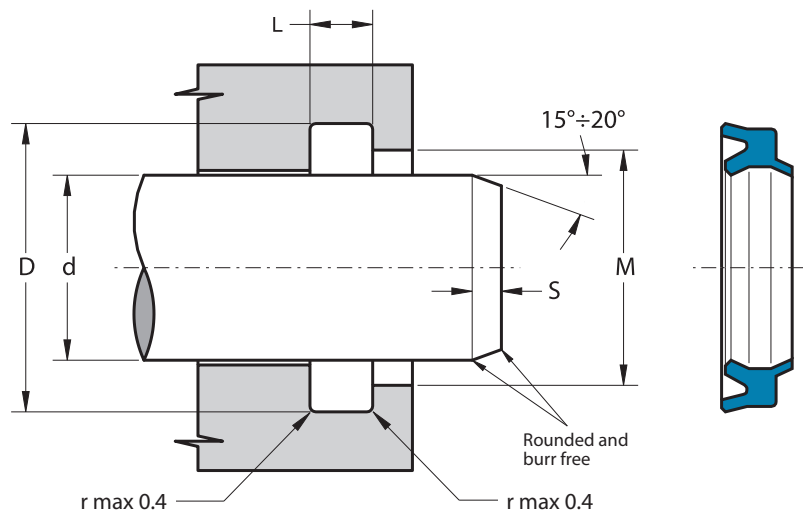

Part.	d <sup>f7</sup>	D <sup>H10</sup>	L <sup>+0.2</sup>	M <sup>+0.2</sup>
SAB 10/ISO	10	16.0	4.0	12.5
SAB 10 20 6	10	20.0	6.5	14.0*
SAB 12	12	18.6	3.8	15.0
SAB 12 26 6.6	12	26.0	7.0	15.0*
SAB 14	14	20.6	3.8	19.0
SAB 14/ISO	14	20.0	4.0	16.5
SAB 16/A	16	24.0	5.0	20.3
SAB 17	17	23.6	3.8	22.0
SAB 18	18	24.6	3.8	21.0
SAB 20	20	28.6	5.3	23.0
SAB 22	22	30.6	5.3	25.0
SAB 22/ISO	22	28.0	4.0	24.5
SAB 25	25	33.6	5.3	28.0
SAB 25/A	25	33.0	4.8	29.3
SAB 28	28	36.6	5.3	31.0
SAB 28/ISO	28	36.0	5.0	31.0
SAB 30	30	38.6	5.3	33.0
SAB 30/A	30	38.0	5.0	33.0
SAB 30/B	30	38.0	5.8	34.0
SAB 32	32	40.6	5.3	35.0

Part.	d <sup>f7</sup>	D <sup>H10</sup>	L <sup>+0.2</sup>	M <sup>+0.2</sup>
SAB 32/ISO	32	40.0	5.0	35.0
SAB 35	35	43.6	5.3	38.0
SAB 36	36	44.6	5.3	39.0
SAB 36/ISO	36	44.0	5.0	39.0
SAB 37	37	45.6	5.3	40.0
SAB 38	38	46.6	5.3	41.0
SAB 40	40	48.6	5.3	43.0
SAB 40/ISO	40	48.0	5.0	43.0
SAB 42	42	50.6	5.3	45.0
SAB 45	45	53.6	5.3	48.0
SAB 45/ISO	45	53.0	5.0	48.0
SAB 50	50	58.6	5.3	53.0
SAB 50/A	50	58.0	4.0	53.0
SAB 50/ISO	50	58.0	5.0	53.0
SAB 55	55	63.6	5.3	58.0
SAB 55/A	55	65.0	6.0	58.0
SAB 56/ISO	56	66.0	6.0	59.0
SAB 60	60	68.6	5.3	63.0
SAB 60/ISO	60	70.0	6.0	63.0
SAB 63	63	71.6	5.3	66.0

Part.	d <sup>f7</sup>	D <sup>H10</sup>	L <sup>+0.2</sup>	M <sup>+0.2</sup>
SAB 63/ISO	63	73.0	6.0	66.0
SAB 65	65	73.6	5.3	68.0
SAB 65/A	65	75.0	6.0	68.0
SAB 70	70	78.6	5.3	73.0
SAB 70/ISO	70	80.0	6.0	73.0
SAB 75	75	83.6	5.3	78.0
SAB 78/A	78	88.2	7.1	84.0
SAB 80	80	88.6	5.3	83.0
SAB 80/ISO	80	90.0	6.0	83.0
SAB 82/A	82	94.2	7.1	88.0
SAB 85	85	97.2	7.1	91.0
SAB 90	90	102.2	7.1	96.0
SAB 90/ISO	90	100.0	6.0	93.0
SAB 100	100	112.2	7.1	106.0
SAB 100/A	100	110.0	6.0	103.0
SAB 104	104	116.2	7.1	110.0
SAB 110	110	122.2	7.1	116.0
SAB 129	129	141.2	7.1	135.0
SAB 154	154	166.2	7.1	160.0
SAB 180	180	192.2	7.1	186.0

\* Open groove assembly

# SAD



SAD

MATERIAL			
	Type Polyurethane	Designation SEALPUR 93	Hardness 93 °ShA
FIELD OF APPLICATION			
Speed ≤ 0.8 m/s			
Temperature -40°C ÷ +100°C			
Fluids	Hydraulic oils (mineral oil based) For other fluids contact our technical department		
SURFACE ROUGHNESS			
Dynamic surface	Ra ≤ 0.3 µm	Rt ≤ 2.5 µm	
Static surface	Ra ≤ 1.6 µm	Rt ≤ 6.3 µm	
LEAD-IN CHAMFERS			
	d	Smin	
	less 100	5 mm	
	100÷200	7 mm	
	over 200	10 mm	

Any pressure loads on the back of the rings should be avoided. Sharp edges and burrs within the installation area must be removed.

The above data are maximum values, they may be maintained for short periods and can not be used at the same time simultaneously.

The functions of the Aston Seals SAD bi-directional rod wiper are:

- to prevent introduction of dust, dirt and foreign matter into the system; this is achieved by a special wiper lip which produces a very effective cleaning action, prevents the development of scores, protects the guiding parts and extends the service life of the axial moving rod seals.
- to retain residual oil film on the rod; the asymmetric lips are designed to differentiate the behaviour of the lips on the static and dynamic surfaces: the static lips are flexible and more sensitive to pressure fluctuations; the dynamic lip is shorter and stronger to concentrate load against the dynamic surface.

This wiper is preferably used in conjunction with a rod seal with a hydrodynamic back-pumping function (i.e. XB).

We recommend in any case a pressure release hold

be provided in front of the double wiper in order to avoid pressure build-up between seal and wiper.

The material used to produce this wiper is a polyurethane compound that ensures excellent properties in case of dry run, an increased wear-resistance and an extended service life due to good resistance against ozone and radiation caused by weather conditions.

- Retaining residual oil film
- External flush fitting for a good housing protection
- Extended service life
- Insensitive to structural deflections
- Excellent wear-resistance
- Space-saving construction
- No close tolerances are necessary
- Easy installation without expensive auxiliaries

# SAD

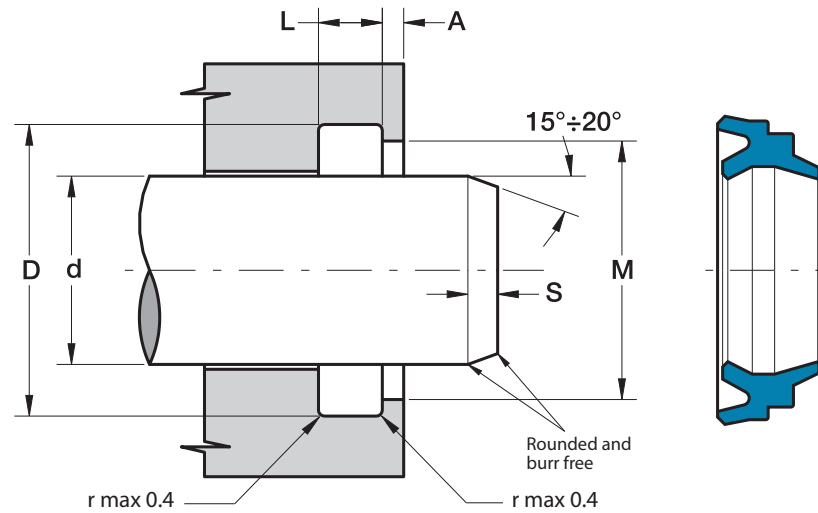

Part.	d <sup>f7</sup>	D <sup>H10</sup>	L <sup>+0.15</sup>	M <sup>H11</sup>	A <sup>±0.1</sup>
<b>SAD 20</b>	20	28	4	26	2
<b>SAD 25</b>	25	33	4	31	2
<b>SAD 30</b>	30	38	4	36	2
<b>SAD 35</b>	35	43	4	41	2
<b>SAD 40</b>	40	48	4	46	2
<b>SAD 45</b>	45	53	4	51	2
<b>SAD 50</b>	50	58	4	56	2
<b>SAD 60</b>	60	68	4	66	2
<b>SAD 70</b>	70	78	4	76	2
<b>SAD 80</b>	80	88	4	86	2
<b>SAD 90</b>	90	98	4	96	2
<b>SAD 100</b>	100	108	4	106	2
<b>SAD 120</b>	120	132	5.5	129	2.7

# SAF/GM



SAF/GM

The function of the Aston Seals SAF/GM wiper ring is to prevent introduction of dust, dirt and foreign matter into the system. This is achieved by a special wiper lip which produces a very effective cleaning action, prevents the development of scores, protects the guiding parts and extends the service life of the axial moving rod seals.

A flush fitting with the outside diameter of the metal cage prevents moisture from entering the groove.

The material used to produce the wiper element is a polyurethane compound that ensures excellent properties in case of dry run, an increased wear-resistance and an extended service life due to good resistance against

ozone and radiation caused by weather conditions.

- Easy construction housing
- Tight fit in the groove
- Extended service life
- Low cost solution
- Excellent wear-resistance
- Space-saving construction

## MATERIAL

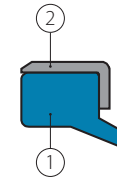

① **Type** Polyurethane  
**Designation** SEALPUR 93  
**Hardness** 93 °ShA

② **Type** Not alloyed steel

## FIELD OF APPLICATION

**Speed**  
 ≤ 0.8 m/s



**Temperature**  
 -40°C ÷ +100°C

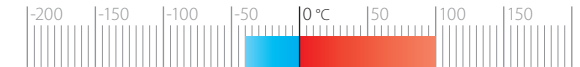

**Fluids**

Hydraulic oils (mineral oil based)  
 For other fluids contact our technical department

## SURFACE ROUGHNESS

**Dynamic surface** Suitable for rod seal system  
**Static surface** Ra ≤ 1.6 μm Rt ≤ 6.3 μm

## LEAD-IN CHAMFERS

d	Smin
less 100	5 mm
100÷200	7 mm
over 200	10 mm

Pay attention to the groove "D" diameter because, if larger, the wiper could be ejected during work.

Any pressure loads on the back of the rings should be avoided.  
 Sharp edges and burrs within the installation area must be removed.

The above data are maximum values, they may be maintained for short periods and can not be used at the same time simultaneously.

# SAF/GM

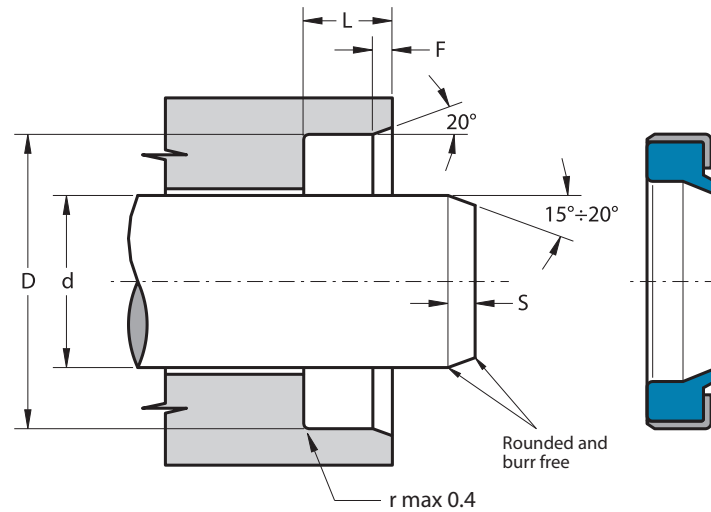

Part.	d <sup>f7</sup>	D <sup>H8</sup>	L <sup>+0.2</sup>	F
SAF 14 22 4.5 /GM	14	22	4.5	0.5
SAF 15 23 4.5 /GM	15	23	4.5	0.5
SAF 16 22 4.5 /GM	16	22	4.5	0.5
SAF 16 24 4.5 /GM	16	24	4.5	0.5
SAF 16 26 5 /GM	16	26	5.0	0.5
SAF 18 26 4.5 /GM	18	26	4.5	0.5
SAF 20 30 4 /GM	20	30	4.0	0.8
SAF 20 30 6 /GM	20	30	6.0	0.8
SAF 22 32 5 /GM	22	32	5.0	0.8
SAF 25 35 6 /GM	25	35	6.0	0.8
SAF 28 38 6 /GM	28	38	6.0	0.8
SAF 30 40 5 /GM	30	40	5.0	0.8
SAF 30 40 6 /GM	30	40	6.0	0.8
SAF 32 42 6 /GM	32	42	6.0	0.8
SAF 35 45 6 /GM	35	45	6.0	0.8
SAF 36 46 6 /GM	36	46	6.0	0.8

Part.	d <sup>f7</sup>	D <sup>H8</sup>	L <sup>+0.2</sup>	F
SAF 40 50 6 /GM	40	50	6.0	0.8
SAF 42 52 6 /GM	42	52	6.0	0.8
SAF 45 55 6 /GM	45	55	6.0	0.8
SAF 50 60 6 /GM	50	60	6.0	0.8
SAF 50 60 7 /GM	50	60	7.0	0.8
SAF 55 65 5 /GM	55	65	5.0	0.8
SAF 55 65 6 /GM	55	65	6.0	0.8
SAF 60 70 6 /GM	60	70	6.0	0.8
SAF 65 75 6 /GM	65	75	6.0	0.8
SAF 65 79 8 /GM	65	79	8.0	0.8
SAF 70 80 7 /GM	70	80	7.0	0.8

Inch sizes

SAF 1000 1375 0187 /GM	25.4	34.93	4.75	0.8
------------------------	------	-------	------	-----

# SMI



SMI

## MATERIAL

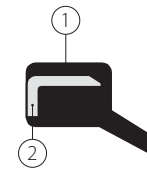

① <b>Type</b>	Nitril Rubber NBR
<b>Designation</b>	RUBSEAL 90
<b>Hardness</b>	90 °ShA
② <b>Type</b>	Not alloyed steel

## FIELD OF APPLICATION



**Fluids**  
Hydraulic oils (mineral oil based)  
For other fluids contact our technical department

## SURFACE ROUGHNESS

<b>Dynamic surface</b>	Suitable for rod seal system
<b>Static surface</b>	Ra ≤ 1.6 µm      Rt ≤ 6.3 µm

## LEAD-IN CHAMFERS

d	Smin
less 100	5 mm
100÷200	7 mm
over 200	10 mm

Pay attention to the groove "D" diameter because, if larger, the wiper could be ejected during work.

Any pressure loads on the back of the rings should be avoided. Sharp edges and burrs within the installation area must be removed.

The above data are maximum values, they may be maintained for short periods and can not be used at the same time simultaneously.

The function of the Aston Seals SMI wiper ring is to prevent introduction of dust, dirt and foreign matter into the system. This is achieved by a special wiper lip which produces a very effective cleaning action, prevents the development of scores, protects the guiding parts and extends the service life of the axial moving rod seals.

A flush fitting with the outside diameter of the metal cage prevents moisture from entering the groove.

The material used to produce the wiper element is a nitril rubber with hardness 90 °ShA that ensures a good wear-resistance in case of dry run and an extended service life.

- Easy construction housing
- Tight fit in the groove
- High speed allowed
- Good wear-resistance
- Extended service life
- Low cost solution
- Space-saving construction

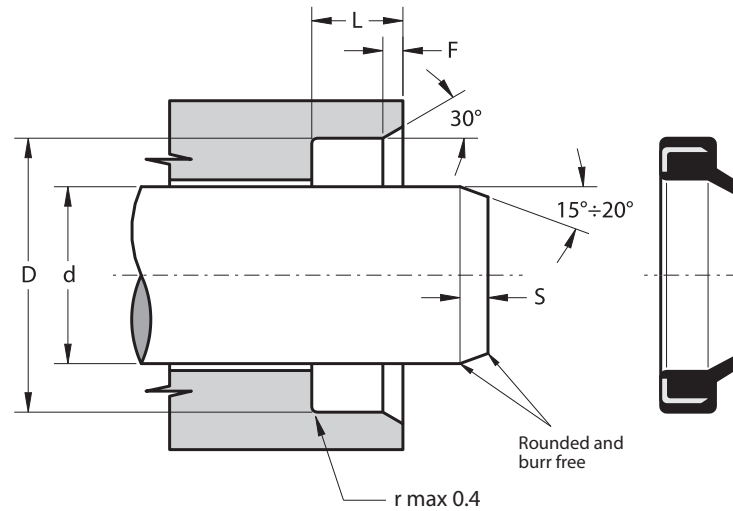

Part.	d <sup>f7</sup>	D <sup>H8</sup>	L <sup>+0.2</sup>	F
SMI 6 13 3.5	6	13	3.5	0.5
SMI 8 14 3.5	8	14	3.5	0.6
SMI 10 16 3.5	10	16	3.5	0.6
SMI 12 18 3.5	12	18	3.5	0.6
SMI 14 20 3.5	14	20	3.5	0.6
SMI 15 21 3.5	15	21	3.5	0.6
SMI 15 25 5	15	25	5.0	1.0
SMI 16 22 3.5	16	22	3.5	0.5
SMI 16 26 5	16	26	5.0	1.0
SMI 18 24 4	18	24	4.0	0.8
SMI 18 28 5	18	28	5.0	1.0
SMI 20 30 5	20	30	5.0	1.0
SMI 20 30 7	20	30	7.0	1.5
SMI 22 32 5	22	32	5.0	1.0
SMI 22 32 7	22	32	7.0	1.5
SMI 25 35 5	25	35	5.0	1.0
SMI 25 35 7	25	35	7.0	1.5
SMI 26 35 7	26	35	7.0	1.5

Part.	d <sup>f7</sup>	D <sup>H8</sup>	L <sup>+0.2</sup>	F
SMI 28 38 5	28	38	5.0	1.0
SMI 30 40 5	30	40	5.0	1.0
SMI 30 40 7	30	40	7.0	1.5
SMI 32 42 5	32	42	5.0	1.0
SMI 35 45 7	35	45	7.0	1.5
SMI 36 45 7	36	45	7.0	1.5
SMI 36 46 5	36	46	5.0	1.0
SMI 38 48 7	38	48	7.0	1.5
SMI 40 50 5	40	50	5.0	1.0
SMI 40 50 7	40	50	7.0	1.5
SMI 45 55 5	45	55	5.0	1.0
SMI 45 55 7	45	55	7.0	1.5
SMI 50 60 5	50	60	5.0	1.0
SMI 50 60 7	50	60	7.0	1.5
SMI 55 65 5	55	65	5.0	1.0
SMI 55 65 7	55	65	7.0	1.5
SMI 60 70 5	60	70	5.0	1.0
SMI 60 70 7	60	70	7.0	1.5

Part.	d <sup>f7</sup>	D <sup>H8</sup>	L <sup>+0.2</sup>	F
SMI 65 75 5	65	75	5.0	1.0
SMI 65 75 7	65	75	7.0	1.5
SMI 70 80 5	70	80	5.0	1.0
SMI 70 80 7	70	80	7.0	1.5
SMI 75 83 7	75	83	7.0	1.5
SMI 75 85 7	75	85	7.0	1.5
SMI 80 88 7	80	88	7.0	1.5
SMI 80 90 7	80	90	7.0	1.5
SMI 85 95 7	85	95	7.0	1.5
SMI 90 100 7	90	100	7.0	1.5
SMI 100 110 7	100	110	7.0	1.5
SMI 100 120 7	100	120	7.0	1.5
SMI 110 120 7	110	120	7.0	1.5
SMI 120 130 7	120	130	7.0	1.5
SMI 130 145 9	130	145	9.0	2.0
SMI 140 155 9	140	155	9.0	2.0
SMI 150 165 9	150	165	9.0	2.0
SMI 160 175 9	160	175	9.0	2.0

# SMA



SMA

The function of the Aston Seals SMA wiper ring is to prevent introduction of dust, dirt and foreign matter into the system. This is achieved by a special wiper lip which produces a very effective cleaning action, prevents the development of scores, protects the guiding parts and extends the service life of the axial moving rod seals.

A flush fitting with the outside diameter of the metal cage prevents moisture from entering the groove.

The material used to produce the wiper element is a nitril rubber with hardness 90 °ShA that ensures a good wear-resistance in case of dry run and an extended service life.

- Easy construction housing
- Tight fit in the groove
- High speed allowed
- Good wear-resistance
- Extended service life
- Low cost solution
- Space-saving construction

## MATERIAL

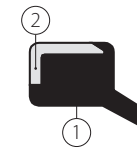

①	Type	Nitril Rubber NBR
	Designation	RUBSEAL 90
	Hardness	90 °ShA
②	Type	Not alloyed steel

## FIELD OF APPLICATION

Speed  
≤ 2 m/s



Temperature  
-30°C ÷ +100°C

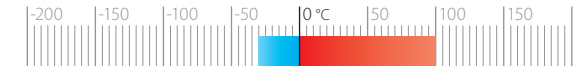

Fluids

Hydraulic oils (mineral oil based)  
For other fluids contact our technical department

## SURFACE ROUGHNESS

Dynamic surface	Suitable for rod seal system	
Static surface	Ra ≤ 1.6 μm	Rt ≤ 6.3 μm

## LEAD-IN CHAMFERS

d	Smin
less 100	5 mm
100÷200	7 mm
over 200	10 mm

Pay attention to the groove "D" diameter because, if larger, the wiper could be ejected during work.

Any pressure loads on the back of the rings should be avoided.  
Sharp edges and burrs within the installation area must be removed.

The above data are maximum values, they may be maintained for short periods and can not be used at the same time simultaneously.



# SMA

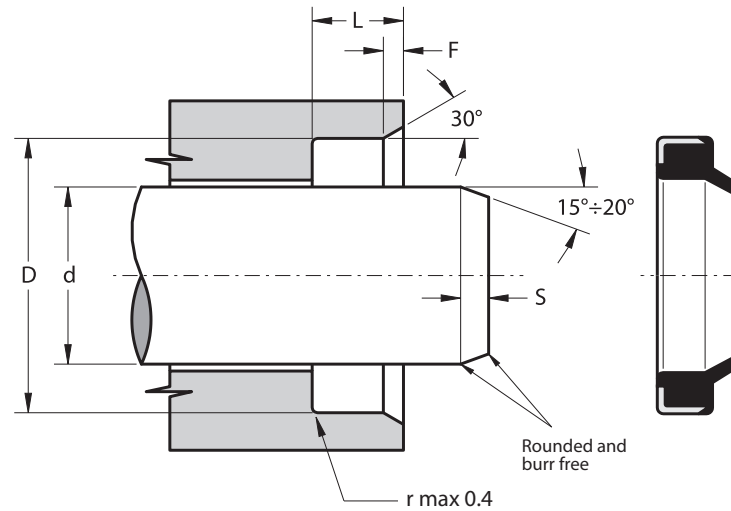

Part.	d <sup>f7</sup>	D <sup>H8</sup>	L <sup>+0.2</sup>	F
SMA 12 20 4	12	20	4	0.8
SMA 16 22 3	16	22	3	0.5
SMA 16 26 5	16	26	5	1.0
SMA 20 28 3	20	28	3	0.6
SMA 20 30 7	20	30	7	1.5
SMA 22 28 5	22	28	5	1.0
SMA 22 32 5	22	32	5	1.0
SMA 25 35 7	25	35	7	1.5
SMA 30 40 5	30	40	5	1.0
SMA 32 45 7	32	45	7	1.5
SMA 35 45 7	35	45	7	1.5
SMA 40 50 5	40	50	5	1.0
SMA 40 50 7	40	50	7	1.5
SMA 45 55 7	45	55	7	1.5

Part.	d <sup>f7</sup>	D <sup>H8</sup>	L <sup>+0.2</sup>	F
SMA 45 60 7	45	60	7	1.5
SMA 50 60 7	50	60	7	1.5
SMA 50 65 5	50	65	5	1.0
SMA 55 65 7	55	65	7	1.0
SMA 60 70 7	60	70	7	1.5
SMA 65 75 7	65	75	7	1.5
SMA 70 80 7	70	80	7	1.5
SMA 75 85 7	75	85	7	1.5
SMA 80 90 7	80	90	7	1.5
SMA 90 100 7	90	100	7	1.5
SMA 95 105 7	95	105	7	1.5
SMA 100 110 7	100	110	7	1.5
SMA 110 120 7	110	120	7	1.5
SMA 120 130 7	120	130	7	1.5

# SAA



The function of external wiper ring Aston Seals SAA is to prevent introduction of dust, dirt and foreign matter into the single-acting cylinder which has an opening to the atmosphere.

This is achieved by a special external wiper lip which produces a very effective cleaning action on the internal cylinder surface, prevents the development of scores, protects the guiding parts and extends the service life of the axial moving piston seals.

The material used to produce this wiper is a polyurethane compound that ensures excellent properties in case of dry run, an increased wear-resistance and an extended service life.

- Excellent wear-resistance
- Extended service life
- No close tolerances are necessary
- Low cost solution
- Space-saving construction
- Easy installation without expensive auxiliaries

## MATERIAL



### Type

Polyurethane

### Designation

SEALPUR 93

### Hardness

93 °ShA

## FIELD OF APPLICATION

Speed  
≤ 0.8 m/s



Temperature  
-40°C ÷ +100°C

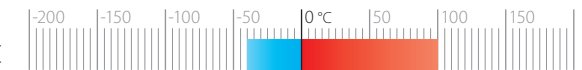

### Fluids

Hydraulic oils (mineral oil based)

For other fluids contact our technical department

## SURFACE ROUGHNESS

Dynamic surface  
Static surface

Suitable for piston seal system

Ra ≤ 1.6 μm      Rt ≤ 6.3 μm

## LEAD-IN CHAMFERS

d

Smin

less 100  
100÷200  
over 200

5 mm  
7 mm  
10 mm

Any pressure loads on the back of the rings should be avoided.  
Sharp edges and burrs within the installation area must be removed.  
The above data are maximum values, they may be maintained for short periods and can not be used at the same time simultaneously.

# SAA

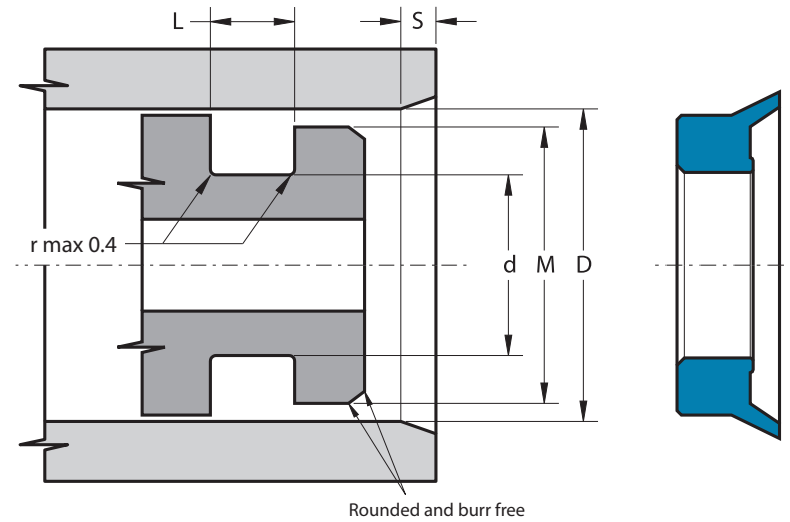

Part.	D <sup>H10</sup>	d <sup>+0.1</sup>	L <sup>+0.25</sup>	M
<b>SAA 30</b>	30	21.4	5.3	27
<b>SAA 40</b>	40	31.4	5.3	37
<b>SAA 50</b>	50	41.4	5.3	47
<b>SAA 55</b>	55	46.4	5.3	52
<b>SAA 60</b>	60	51.4	5.3	57
<b>SAA 63</b>	63	54.4	5.3	60
<b>SAA 70</b>	70	61.4	5.3	67
<b>SAA 80</b>	80	71.4	5.3	77
<b>SAA 90</b>	90	81.4	5.3	87
<b>SAA 95</b>	95	86.4	5.3	92
<b>SAA 100</b>	100	91.4	5.3	97
<b>SAA 100/B</b>	100	88.0	7.5	94
<b>SAA 110</b>	110	101.4	5.3	107
<b>SAA 115</b>	115	106.4	5.3	112
<b>SAA 115/A</b>	115	107.0	5.0	111
<b>SAA 115/B</b>	115	100.0	10.0	107.5
<b>SAA 120</b>	120	111.4	5.3	117
<b>SAA 125</b>	125	116.4	5.3	122
<b>SAA 130</b>	130	121.4	5.3	127
<b>SAA 140</b>	140	131.4	5.3	137

# S1A



S1A

The function of the Aston Seals S1A wiper ring is to prevent introduction of dust, dirt and foreign matter into the system. It is composed of:

- A dynamic element with a special wiper lip which produces a very effective cleaning action, prevents the development of scores, protects the guiding parts and extends the service life of the axial moving rod seals. The material used to produce this wiper assures exceptional low friction and high speed performance, high compatibility with nearly all media due to the chemical resistance which exceeds that of all other thermoplastics and elastomers
- A standard size O-Ring with low permanent deformation as an energizing component on

the static side which keeps the pressure of the wiper lip against the sliding surface and can compensate any deflections of the rod.

- Low static and dynamic friction
- High speed allowed
- No tendency of stick-slip
- Space-saving construction and simple groove design
- High compatibility with nearly all fluids (with the right choice of O-Ring material)
- High temperature resistance

## MATERIAL



① **Type** Polytetrafluoroethylene PTFE + Bronze  
**Designation** SEALFLON + Bronze  
 ⇒ It can be provided with different fillers according to applications

② **Type** Nitril Rubber NBR  
**Designation** RUBSEAL 70  
**Hardness** 70 °ShA  
 ⇒ It can be provided with different materials according to working conditions

## FIELD OF APPLICATION

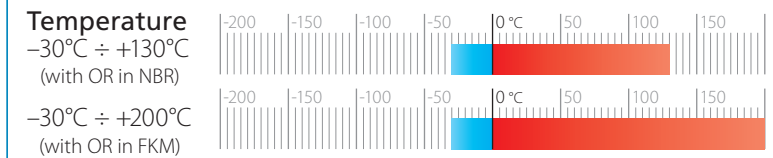

**Fluids** High compatibility with nearly all fluids (with the right choice of O-Ring material)

## SURFACE ROUGHNESS

**Dynamic surface** Suitable for rod seal system  
**Static surface** Ra ≤ 1.6 µm Rt ≤ 6.3 µm

## LEAD-IN CHAMFERS

L		S	
L	S	L	S
3.7	2.0	8.4	6.5
5.0	2.5	11.0	7.5
6.0	3.5	14.0	10.0

Sharp edges and burrs within the installation area must be removed.

The above data are maximum values, they may be maintained for short periods and can not be used at the same time simultaneously.

# S1A

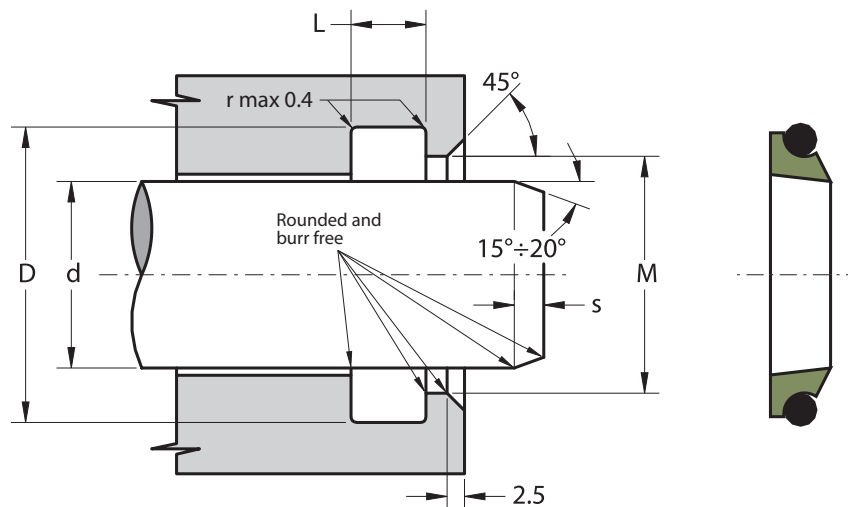

Part.	d <sup>f8</sup>	D <sup>H9</sup>	L <sup>+0.2</sup>	M <sup>±0.1</sup>	OR
<b>S1A 8 12.8 3.7</b>	8	12.8	3.7	10.7	012
<b>S1A 10 14.8 3.7</b>	10	14.8	3.7	12.7	013
<b>S1A 12 18.8 5</b>	12	18.8	5.0	15.5	113
<b>S1A 14 20.8 5</b>	14	20.8	5.0	17.5	114
<b>S1A 15 21.8 5</b>	15	21.8	5.0	18.5	115
<b>S1A 16 22.8 5</b>	16	22.8	5.0	19.5	116
<b>S1A 18 24.8 5</b>	18	24.8	5.0	21.5	117
<b>S1A 20 26.8 5</b>	20	26.8	5.0	23.5	118
<b>S1A 24 30.8 5</b>	24	30.8	5.0	27.5	120
<b>S1A 25 31.8 5</b>	25	31.8	5.0	28.5	121
<b>S1A 28 34.8 5</b>	28	34.8	5.0	31.5	123
<b>S1A 30 36.8 5</b>	30	36.8	5.0	33.5	124
<b>S1A 32 38.8 5</b>	32	38.8	5.0	35.5	126
<b>S1A 35 41.8 5</b>	35	41.8	5.0	38.5	127
<b>S1A 40 46.8 5</b>	40	46.8	5.0	43.5	131
<b>S1A 42 48.8 5</b>	42	48.8	5.0	45.5	132
<b>S1A 45 51.8 5</b>	45	51.8	5.0	48.5	134
<b>S1A 50 56.8 5</b>	50	56.8	5.0	53.5	137
<b>S1A 55 61.8 5</b>	55	61.8	5.0	58.5	140

Part.	d <sup>f8</sup>	D <sup>H9</sup>	L <sup>+0.2</sup>	M <sup>±0.1</sup>	OR
<b>S1A 56 62.8 5</b>	56	62.8	5.0	59.5	141
<b>S1A 60 66.8 5</b>	60	66.8	5.0	63.5	143
<b>S1A 65 73.8 6</b>	65	73.8	6.0	69.0	231
<b>S1A 70 78.8 6</b>	70	78.8	6.0	74.0	233
<b>S1A 75 83.8 6</b>	75	83.8	6.0	79.0	234
<b>S1A 80 88.8 6</b>	80	88.8	6.0	84.0	236
<b>S1A 85 93.8 6</b>	85	93.8	6.0	89.0	237
<b>S1A 90 98.8 6</b>	90	98.8	6.0	94.0	239
<b>S1A 95 103.8 6</b>	95	103.8	6.0	99.0	241
<b>S1A 100 108.8 6</b>	100	108.8	6.0	104.0	242
<b>S1A 110 118.8 6</b>	110	118.8	6.0	114.0	245
<b>S1A 120 128.8 6</b>	120	128.8	6.0	124.0	249
<b>S1A 125 133.8 6</b>	125	133.8	6.0	129.0	250
<b>S1A 130 138.8 6</b>	130	138.8	6.0	134.0	252
<b>S1A 140 148.8 6</b>	140	148.8	6.0	144.0	255
<b>S1A 160 168.8 6</b>	160	168.8	6.0	164.0	260
<b>S1A 170 178.8 6</b>	170	178.8	6.0	174.0	261
<b>S1A 180 188.8 6</b>	180	188.8	6.0	184.0	263
<b>S1A 200 208.8 6</b>	200	208.8	6.0	204.0	266

Other sizes not present in the above table can be provided in according to the following scheme:

d	D	M	L	S. OR
4 ÷ 11.9	d + 4.8	d + 2.7	3.7	1.78
12 ÷ 64.9	d + 6.8	d + 3.5	5.0	2.62
65 ÷ 250.9	d + 8.8	d + 4.0	6.0	3.53
251 ÷ 420.9	d + 12.2	d + 4.5	8.4	5.34
421 ÷ 650.9	d + 16.0	d + 5.2	11.0	6.99

# S2A



S2A

The function of the Aston Seals S2A wiper ring is to prevent introduction of dust, dirt and foreign matter into the system. This wiper can carry out good sealing action if used in conjunction with a rod seal with hydrodynamic back-pumping function. It is composed of:

- A dynamic element with a special wiper lip which produces a very effective cleaning action, prevents the development of scores, protects the guiding parts and extends the service life of the axial moving rod seals. The material used to produce this wiper assures exceptional low friction and high speed performance, high compatibility with nearly all media due to the chemical resistance which exceeds that of all other

thermoplastics and elastomers

- A standard size O-Ring with low permanent deformation as an energizing component on the static side which keeps the pressure of the wiper lip against the sliding surface and can compensate any deflections of the rod.
- Low static and dynamic friction
- High speed allowed
- No tendency of stick-slip
- Space-saving construction and simple groove design
- High compatibility with nearly all fluids (with the right choice of O-Ring material)
- High temperature resistance

## MATERIAL



① **Type** Polytetrafluoroethylene PTFE + Bronze  
**Designation** SEALFLON + Bronze

⇒ It can be provided with different fillers according to applications

② **Type** Nitril Rubber NBR  
**Designation** RUBSEAL 70  
**Hardness** 70 °ShA

⇒ It can be provided with different materials according to working conditions

## FIELD OF APPLICATION

**Speed**  
 ≤ 15 m/s

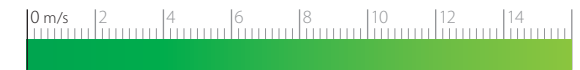

**Temperature**  
 -30°C ÷ +130°C  
 (with OR in NBR)

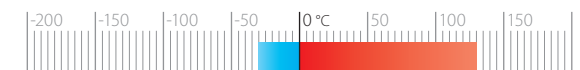

-30°C ÷ +200°C  
 (with OR in FKM)

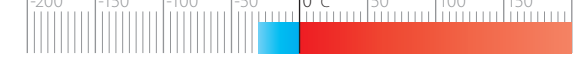

**Fluids**

High compatibility with nearly all fluids  
 (with the right choice of O-Ring material)

## SURFACE ROUGHNESS

**Dynamic surface**  
**Static surface**

Suitable for rod seal system  
 Ra ≤ 1.6 µm Rt ≤ 6.3 µm

## LEAD-IN CHAMFERS

L		S	
3.7	5.0	2.0	3.5
6.0		8.4	10.0

Sharp edges and burrs within the installation area must be removed.

The above data are maximum values, they may be maintained for short periods and can not be used at the same time simultaneously.

# S2A

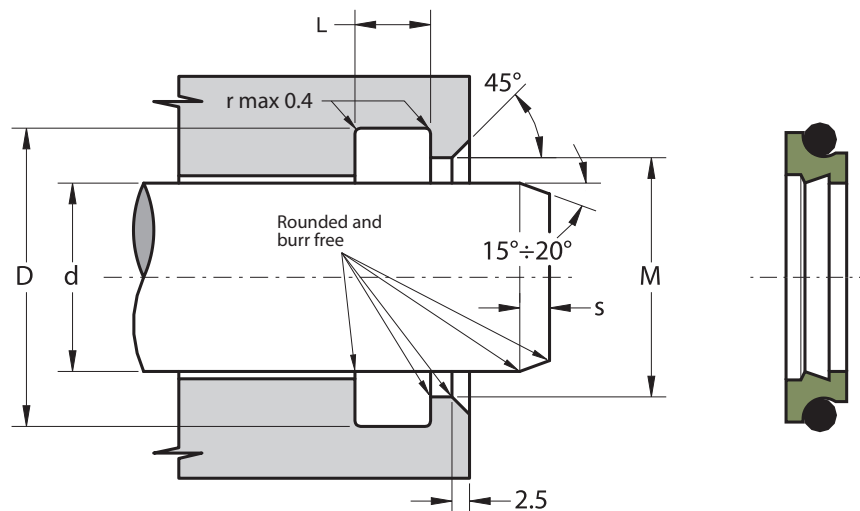

Part.	d <sup>f8</sup>	D <sup>H9</sup>	L <sup>+0.2</sup>	M <sup>±0.1</sup>	OR
S2A 8 12.8 3.7	8	12.8	3.7	9.0	012
S2A 10 14.8 3.7	10	14.8	3.7	11.0	013
S2A 12 18.8 5	12	18.8	5.0	13.5	113
S2A 14 20.8 5	14	20.8	5.0	15.5	114
S2A 15 21.8 5	15	21.8	5.0	16.5	115
S2A 16 22.8 5	16	22.8	5.0	17.5	116
S2A 18 24.8 5	18	24.8	5.0	19.5	117
S2A 20 26.8 5	20	26.8	5.0	21.5	118
S2A 24 30.8 5	24	30.8	5.0	25.5	120
S2A 25 31.8 5	25	31.8	5.0	26.5	121
S2A 28 34.8 5	28	34.8	5.0	29.5	123
S2A 30 36.8 5	30	36.8	5.0	31.5	124
S2A 32 38.8 5	32	38.8	5.0	33.5	126
S2A 35 41.8 5	35	41.8	5.0	36.5	127
S2A 40 46.8 5	40	46.8	5.0	41.5	131
S2A 42 48.8 5	42	48.8	5.0	43.5	132
S2A 45 51.8 5	45	51.8	5.0	46.5	134
S2A 50 56.8 5	50	56.8	5.0	51.5	137
S2A 55 61.8 5	55	61.8	5.0	56.5	140

Part.	d <sup>f8</sup>	D <sup>H9</sup>	L <sup>+0.2</sup>	M <sup>±0.1</sup>	OR
S2A 56 62.8 5	56	62.8	5.0	57.5	141
S2A 60 66.8 5	60	66.8	5.0	61.5	143
S2A 65 73.8 6	65	73.8	6.0	67.0	231
S2A 70 78.8 6	70	78.8	6.0	72.0	233
S2A 75 83.8 6	75	83.8	6.0	77.0	234
S2A 80 88.8 6	80	88.8	6.0	82.0	236
S2A 85 93.8 6	85	93.8	6.0	87.0	237
S2A 90 98.8 6	90	98.8	6.0	92.0	239
S2A 95 103.8 6	95	103.8	6.0	97.0	241
S2A 100 108.8 6	100	108.8	6.0	102.0	242
S2A 110 118.8 6	110	118.8	6.0	112.0	245
S2A 120 128.8 6	120	128.8	6.0	122.0	249
S2A 125 133.8 6	125	133.8	6.0	127.0	250
S2A 130 138.8 6	130	138.8	6.0	132.0	252
S2A 140 148.8 6	140	148.8	6.0	142.0	255
S2A 160 168.8 6	160	168.8	6.0	162.0	260
S2A 170 178.8 6	170	178.8	6.0	172.0	261
S2A 180 188.8 6	180	188.8	6.0	182.0	263
S2A 200 208.8 6	200	208.8	6.0	202.0	266

Other sizes not present in the above table can be provided in according to the following scheme:

d	D	M	L	S. OR
4 ÷ 11.9	d + 4.8	d + 1.0	3.7	1.78
12 ÷ 64.9	d + 6.8	d + 1.5	5.0	2.62
65 ÷ 250.9	d + 8.8	d + 2.0	6.0	3.53
251 ÷ 420.9	d + 12.2	d + 2.5	8.4	5.34
421 ÷ 650.9	d + 16.0	d + 2.5	11.0	6.99
651 ÷ 999.9	d + 20.0	d + 2.5	14.0	8.40

# SD



SD

Wear and dry run are largely prevented by additional lubricant retained within the gap created by the secondary lip. In some cases this second sealing lip may even act as a substitute for a costly tandem sealing system when complete sealing under certain working conditions can only be achieved by two seals placed one behind the other in separate housing.

It's designed to be less sensitive to pressure fluctuations than typical "U" seals.

The material used to produce this seal is a polyurethane compound that ensures excellent properties on wear-resistance, extended service life and resistance against extrusion.

- Good sealing performance as well as at low pressure
- Extended service life
- Excellent wear-resistance
- Good temperature resistance
- Insensitive to pressure fluctuation
- Easy installation without expensive auxiliaries

### MATERIAL



<b>Type</b>	<b>Designation</b>	<b>Hardness</b>
Polyurethane	SEALPUR 93	93 °ShA

### FIELD OF APPLICATION

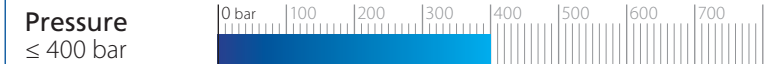

**Fluids** Hydraulic oils (mineral oil based)  
For other fluids contact our technical department

### SURFACE ROUGHNESS

<b>Dynamic surface</b>	Ra ≤ 0.3 μm	Rt ≤ 2.5 μm
<b>Static surface</b>	Ra ≤ 1.6 μm	Rt ≤ 6.3 μm

### GAP DIMENSION "g"

The largest gap dimension appearing in operation on the non-pressurised side:

50 bar	1.20 mm	300 bar	0.25 mm
100 bar	0.80 mm	400 bar	0.17 mm
200 bar	0.40 mm		

### LEAD-IN CHAMFERS

d	Smin
less 100	5 mm
100÷200	7 mm
over 200	10 mm

To avoid damaging the sealing lips during installation, housing must have rounded chamfers. Sharp edges and burrs within the installation area of the seal must be removed.

The above data are maximum values, they may be maintained for short periods and can not be used at the same time simultaneously.



# SD

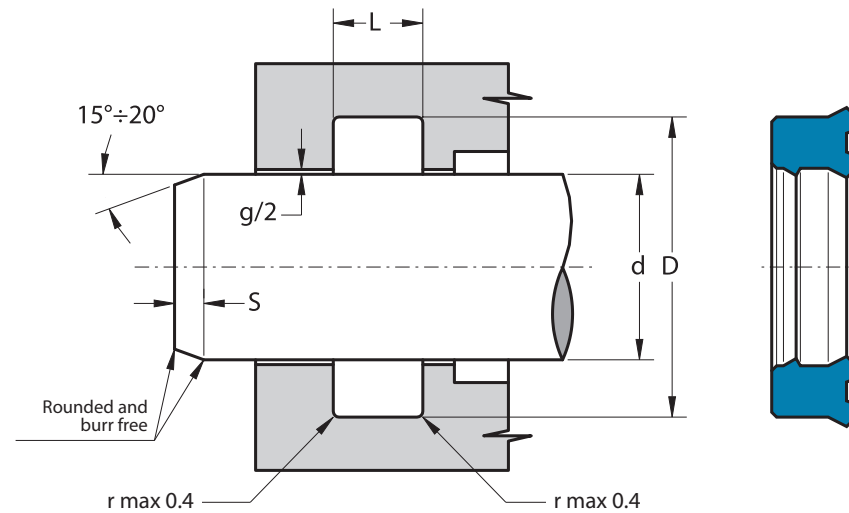

Part.	d <sup>f7</sup>	D <sup>H10</sup>	L <sup>+0.25</sup>
SD 6 14 5.8	6	14.0	6.3
SD 8 15 5.8	8	15.0	6.3
SD 8 16 5.8	8	16.0	6.3
SD 10 16 4.9	10	16.0	5.4
SD 10 18 5.8	10	18.0	6.3
SD 12 19 5.6	12	19.0	6.1
SD 12 19 5.8	12	19.0	6.3
SD 12 20 5.8	12	20.0	6.3
SD 12 23 6.5	12	23.0	7.5
SD 14 20 4.8	14	20.0	5.3
SD 14 22 5.8	14	22.0	6.3
SD 15 21.5 4.2	15	21.5	4.7
SD 15 23 5.8	15	23.0	6.3
SD 16 24 5.8	16	24.0	6.3
SD 18 24 4.7	18	24.0	5.2
SD 18 25 5	18	25.0	5.7
SD 18 26 5.8	18	26.0	6.3
SD 18 26 8	18	26.0	9.0
SD 18 28 5.8	18	28.0	6.3
SD 18 28 7	18	28.0	8.0
SD 20 26 5	20	26.0	5.5
SD 20 26 5.2	20	26.0	5.7
SD 20 27 5.8	20	27.0	6.3
SD 20 28 5.8	20	28.0	6.3

Part.	d <sup>f7</sup>	D <sup>H10</sup>	L <sup>+0.25</sup>
SD 20 28 7	20	28.0	8.0
SD 20 30 4.5	20	30.0	5.0
SD 20 30 7	20	30.0	8.0
SD 22 30 5.8	22	30.0	6.3
SD 22 30 6	22	30.0	7.0
SD 22 30 7	22	30.0	8.0
SD 22 32 7	22	32.0	8.0
SD 22 32 8	22	32.0	9.0
SD 24 34 5.8	24	34.0	6.5
SD 25 32 6	25	32.0	7.0
SD 25 33 5.8	25	33.0	6.3
SD 25 33 6.5	25	33.0	7.5
SD 25 33 7	25	33.0	8.0
SD 25 33 8	25	33.0	9.0
SD 25 35 5.8	25	35.0	6.3
SD 25 35 7	25	35.0	8.0
SD 25 35 8	25	35.0	9.0
SD 25 36 5	25	36.0	5.5
SD 27 37 5.8	27	37.0	6.3
SD 28 36 5.8	28	36.0	6.3
SD 28 36 8	28	36.0	9.0
SD 28 38 7	28	38.0	8.0
SD 30 38 5.8	30	38.0	6.3
SD 30 38 7	30	38.0	8.0

Part.	d <sup>f7</sup>	D <sup>H10</sup>	L <sup>+0.25</sup>
SD 30 38 8	30	38.0	9.0
SD 30 40 6.5	30	40.0	7.5
SD 30 40 7	30	40.0	8.0
SD 30 40 9	30	40.0	10.0
SD 30 40 10	30	40.0	11.0
SD 32 40 5.8	32	40.0	6.3
SD 32 40 6.7	32	40.0	7.7
SD 32 40 8	32	40.0	9.0
SD 32 42 7	32	42.0	8.0
SD 32 42 8	32	42.0	9.0
SD 32 42 10	32	42.0	11.0
SD 32 47 10	32	47.0	11.0
SD 34 41 5	34	41.0	5.5
SD 35 43 5.8	35	43.0	6.3
SD 35 43 6.2	35	43.0	7.0
SD 35 43 8	35	43.0	9.0
SD 35 44 7	35	44.0	8.0
SD 35 45 5.8	35	45.0	6.3
SD 35 45 7	35	45.0	8.0
SD 35 45 10	35	45.0	11.0
SD 35 45 12.5	35	45.0	13.5
SD 35 50 10	35	50.0	11.0
SD 36 44 5.8	36	44.0	6.3
SD 36 44 6.3	36	44.0	7.0

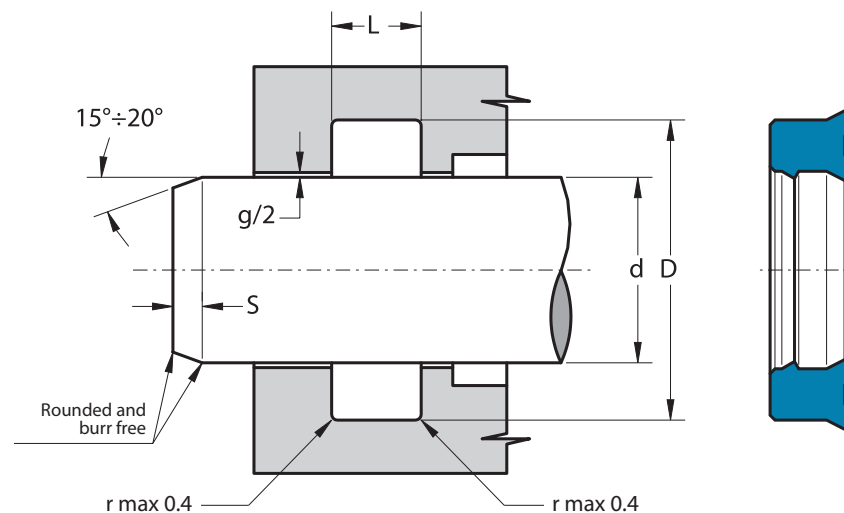

Part.	d <sup>f7</sup>	D <sup>H10</sup>	L <sup>+0.25</sup>
SD 36 44 8	36	44.0	9.0
SD 36 46 7	36	46.0	8.0
SD 36 46 10	36	46.0	11.0
SD 37 47 7	37	47.0	8.0
SD 37 47 8	37	47.0	9.0
SD 37 47 10	37	47.0	11.0
SD 38 45 6	38	45.0	7.0
SD 38 48 6	38	48.0	7.0
SD 38 50 8.5	38	50.0	9.5
SD 40 48 5.8	40	48.0	6.3
SD 40 48 6	40	48.0	7.0
SD 40 48 8	40	48.0	9.0
SD 40 50 5.8	40	50.0	6.3
SD 40 50 7	40	50.0	8.0
SD 40 50 10	40	50.0	11.0
SD 40 55 10	40	55.0	11.0
SD 42 50 6	42	50.0	7.0
SD 42 52 8	42	52.0	9.0
SD 42 53 9	42	53.0	10.0
SD 45 53 5.2	45	53.0	5.7
SD 45 53 5.8	45	53.0	6.3
SD 45 53 8	45	53.0	9.0
SD 45 55 5.8	45	55.0	6.3
SD 45 55 7	45	55.0	8.0

Part.	d <sup>f7</sup>	D <sup>H10</sup>	L <sup>+0.25</sup>
SD 45 55 10	45	55.0	11.0
SD 45 57 9	45	57.0	10.0
SD 45 60 10	45	60.0	11.0
SD 45 60 11.5	45	60.0	12.5
SD 46 54 7.5	46	54.0	8.5
SD 48 60 6	48	60.0	7.0
SD 50 58 8	50	58.0	9.0
SD 50 60 7	50	60.0	8.0
SD 50 60 8	50	60.0	9.0
SD 50 60 9	50	60.0	10.0
SD 50 60 10	50	60.0	11.0
SD 50 62 8	50	62.0	9.0
SD 50 62 10	50	62.0	11.0
SD 50 65 10	50	65.0	11.0
SD 50 65 11.5	50	65.0	12.5
SD 50 70 13.5	50	70.0	14.5
SD 52 64 10	52	64.0	11.0
SD 55 63 8	55	63.0	9.0
SD 55 65 7	55	65.0	8.0
SD 55 65 10	55	65.0	11.0
SD 55 65 12	55	65.0	13.0
SD 55 70 9.5	55	70.0	10.5
SD 56 66 6.5	56	66.0	7.5
SD 56 66 10	56	66.0	11.0

Part.	d <sup>f7</sup>	D <sup>H10</sup>	L <sup>+0.25</sup>
SD 56 71 9.5	56	71.0	10.5
SD 56 71 11.5	56	71.0	12.5
SD 60 68 7	60	68.0	8.0
SD 60 68 8	60	68.0	9.0
SD 60 68 11.5	60	68.0	12.5
SD 60 70 7	60	70.0	8.0
SD 60 70 10	60	70.0	11.0
SD 60 70 11.5	60	70.0	12.5
SD 60 70 12	60	70.0	13.0
SD 60 72 9	60	72.0	10.0
SD 60 75 10	60	75.0	11.0
SD 61 69 7.5	61	69.0	8.5
SD 63 71 8	63	71.0	9.0
SD 63 73 10	63	73.0	11.0
SD 63 75 8.5	63	75.0	9.5
SD 63 75 10	63	75.0	11.0
SD 63 78 11.5	63	78.0	12.5
SD 65 71 8	65	71.0	9.0
SD 65 73 8	65	73.0	9.0
SD 65 75 12	65	75.0	13.0
SD 65 77 8.5	65	77.0	9.5
SD 68 76 8	68	76.0	9.0
SD 70 78 8	70	78.0	9.0
SD 70 80 6.5	70	80.0	7.5

SD

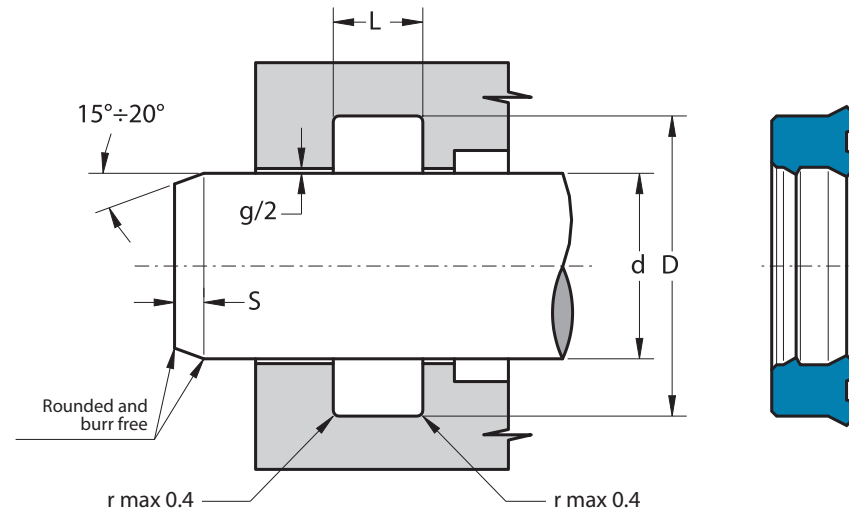

Part.	d <sup>f7</sup>	D <sup>H10</sup>	L <sup>+0.25</sup>
SD 70 80 7	70	80.0	8.0
SD 70 80 10	70	80.0	11.0
SD 70 80 12	70	80.0	13.0
SD 70 82 9	70	82.0	10.0
SD 70 85 11	70	85.0	12.0
SD 75 83 8	75	83.0	9.0
SD 75 85 7	75	85.0	8.0
SD 75 90 10.5	75	90.0	11.5
SD 76 84 7.5	76	84.0	8.5
SD 78 90 12	78	90.0	13.0
SD 80 88 8	80	88.0	9.0
SD 80 88 11.5	80	88.0	12.5
SD 80 89 10	80	89.0	11.0
SD 80 90 7	80	90.0	8.0
SD 80 90 12	80	90.0	13.0
SD 80 92 9	80	92.0	10.0
SD 80 95 11	80	95.0	12.0
SD 80 96 9.5	80	96.0	10.5
SD 82 94 8	82	94.0	9.0
SD 85 93 6.5	85	93.0	7.5
SD 85 93 8	85	93.0	9.0
SD 85 95 7	85	95.0	8.0
SD 85 95 12	85	95.0	13.0
SD 85 97 8.5	85	97.0	9.5

Part.	d <sup>f7</sup>	D <sup>H10</sup>	L <sup>+0.25</sup>
SD 85 100 11.5	85	100.0	12.5
SD 88 96 7.5	88	96.0	8.5
SD 88.9 101.6 9.5	88.9	101.6	10.5
SD 90 100 10	90	100.0	11.0
SD 90 102 9	90	102.0	10.0
SD 90 105 11.5	90	105.0	12.5
SD 91 99 7.5	91	99.0	8.5
SD 95 103 8	95	103.0	9.0
SD 95 104 10	95	104.0	11.0
SD 95 112 11	95	112.0	12.0
SD 97 107 10	97	107.0	11.0
SD 100 108 7	100	108.0	8.0
SD 100 108 8	100	108.0	9.0
SD 100 108 11.5	100	108.0	12.5
SD 100 115 11.5	100	115.0	12.5
SD 104 116 8	104	116.0	9.0
SD 105 113 8	105	113.0	9.0
SD 107 115 7.5	107	115.0	8.5
SD 110 119 10	110	119.0	11.0
SD 110 125 11	110	125.0	12.0
SD 112 122 10.5	112	122.0	11.5
SD 115 123 8	115	123.0	9.0
SD 118 128 10	118	128.0	11.0
SD 120 128 11.5	120	128.0	12.5

Part.	d <sup>f7</sup>	D <sup>H10</sup>	L <sup>+0.25</sup>
SD 120 130 7	120	130.0	8.0
SD 120 130 14	120	130.0	15.0
SD 120 140 12	120	140.0	13.0
SD 124 132 11.5	124	132.0	12.5
SD 125 133 6.5	125	133.0	7.5
SD 126 134 7.5	126	134.0	8.5
SD 129 141 8	129	141.0	9.0
SD 130 150 12	130	150.0	13.0
SD 135 143 8	135	143.0	9.0
SD 135 145 12	135	145.0	13.0
SD 140 148 11.5	140	148.0	12.5
SD 140 150 10	140	150.0	11.0
SD 140 150 11.5	140	150.0	12.5
SD 140 155 8	140	155.0	9.0
SD 140 160 11.5	140	160.0	12.5
SD 145 153 7.5	145	153.0	8.5
SD 150 160 12.5	150	160.0	13.5
SD 150 170 12	150	170.0	13.0
SD 154 166 10	154	166.0	11.0
SD 160 170 12	160	170.0	13.0
SD 175 185 12	175	185.0	13.0
SD 180 190 12.5	180	190.0	13.5
SD 180 192 10	180	192.0	11.0
SD 180 200 12	180	200.0	13.0

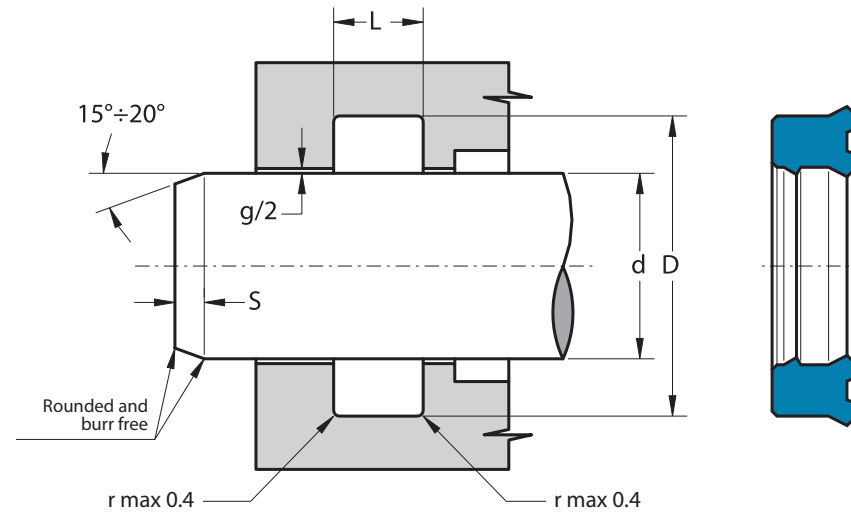

Part.	d <sup>f7</sup>	D <sup>H10</sup>	L <sup>+0.25</sup>
<b>SD 190 210 12</b>	190	210.0	13.0
<b>SD 210 230 15</b>	210	230.0	16.0

Inch sizes

<b>SD 4000 4500 0375</b>	101.6	114.3	10.5
<b>SD 4500 5000 0375</b>	114.3	127.0	10.5
<b>SD 5000 5500 0375</b>	127	139.7	10.5



# SDA

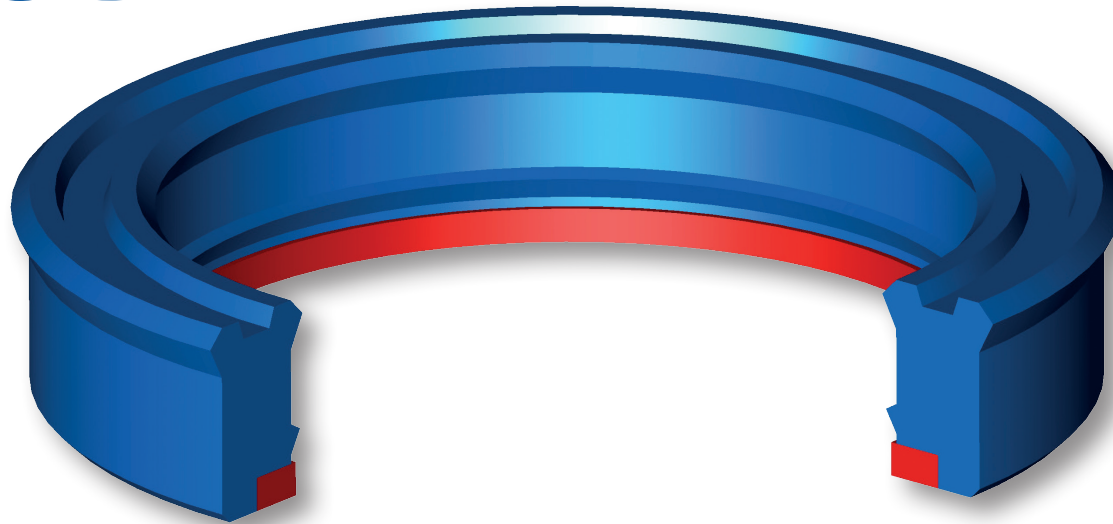

SDA

This seal is mainly used with high pressure and the backup ring offsets large gaps without extrusion.

Wear and dry run are largely prevented by additional lubricant retained within the gap created by the secondary lip. In some cases this second sealing lip may even act as a substitute for a costly tandem sealing system when complete sealing under certain working conditions can only be achieved by two seals placed one behind the other in separate housing.

It's designed to be less sensitive to pressure fluctuations than typical "U" seals.

The material used to produce this seal is a polyurethane compound that ensures excellent properties on wear-resistance,

extended service life and resistance against extrusion.

- Very high resistance against extrusion (backup ring)
- Good sealing performance as well as at low pressure
- Extended service life
- Excellent wear-resistance
- Good temperature resistance
- Insensitive to pressure fluctuation
- Easy installation without expensive auxiliaries

## MATERIAL

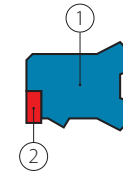

- ① **Type** Polyurethane  
**Designation** SEALPUR 93  
**Hardness** 93 °ShA
- ② **Type** Acetal resin  
**Designation** BEARITE

## FIELD OF APPLICATION

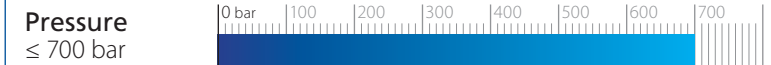

**Fluids** Hydraulic oils (mineral oil based)  
For other fluids contact our technical department

## SURFACE ROUGHNESS

<b>Dynamic surface</b>	Ra ≤ 0.3 μm	Rt ≤ 2.5 μm
<b>Static surface</b>	Ra ≤ 1.6 μm	Rt ≤ 6.3 μm

## GAP DIMENSION "g"

The largest gap dimension appearing in operation on the non-pressurised side:

200 bar	0.80 mm	500 bar	0.40 mm
300 bar	0.65 mm	600 bar	0.33 mm
400 bar	0.50 mm	700 bar	0.25 mm

## LEAD-IN CHAMFERS

d	Smin
less 100	5 mm
100÷200	7 mm
over 200	10 mm

To avoid damaging the sealing lips during installation, housing must have rounded chamfers. Sharp edges and burrs within the installation area of the seal must be removed.

The above data are maximum values, they may be maintained for short periods and can not be used at the same time simultaneously.

# SDA

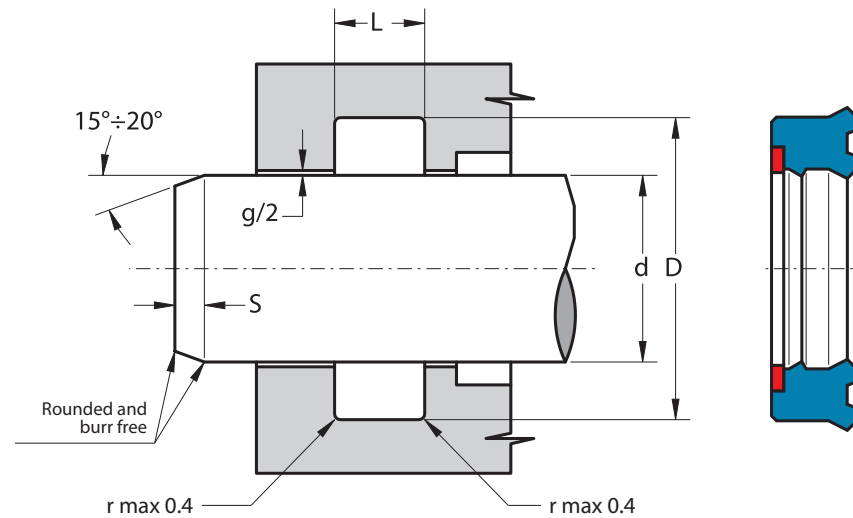

Part.	d <sup>f7</sup>	D <sup>H10</sup>	L <sup>+0.25</sup>
SDA 25 33 5.8	25	33.0	6.3
SDA 40 48 8	40	48.0	9.0
SDA 40 50 10	40	50.0	11.0
SDA 40 52 10	40	52.0	11.0
SDA 40 55 10	40	55.0	11.0
SDA 45 53 9.5	45	53.0	10.5
SDA 45 55 10	45	55.0	11.0
SDA 45 60 10	45	60.0	11.0
SDA 50 60 10	50	60.0	11.0
SDA 50 65 10	50	65.0	11.0
SDA 55 65 10	55	65.0	11.0
SDA 55 70 9.5	55	70.0	10.5
SDA 56 71 11.5	56	71.0	12.5
SDA 60 70 12.5	60	70.0	13.5
SDA 60 75 12	60	75.0	13.0
SDA 60 80 12	60	80.0	13.0
SDA 63 75 12	63	75.0	13.0

Part.	d <sup>f7</sup>	D <sup>H10</sup>	L <sup>+0.25</sup>
SDA 63 78 11.5	63	78.0	12.5
SDA 63 83 12	63	83.0	13.0
SDA 65 75 12	65	75.0	13.0
SDA 65 80 11.5	65	80.0	12.5
SDA 70 80 7	70	80.0	8.0
SDA 70 85 12	70	85.0	13.0
SDA 70 90 13.5	70	90.0	14.5
SDA 75 85 12	75	85.0	13.0
SDA 75 90 12	75	90.0	13.0
SDA 75 95 13.5	75	95.0	14.5
SDA 80 88 9	80	88.0	10.0
SDA 80 95 11	80	95.0	12.0
SDA 80 96 9.5	80	96.0	10.5
SDA 80 100 11.5	80	100.0	12.5
SDA 80 100 13.5	80	100.0	14.5
SDA 90 105 8.5	90	105.0	9.5
SDA 90 105 12	90	105.0	13.0

Part.	d <sup>f7</sup>	D <sup>H10</sup>	L <sup>+0.25</sup>
SDA 90 110 12	90	110.0	13.0
SDA 95 115 13.5	95	115.0	14.5
SDA 100 108 8	100	108.0	9.0
SDA 100 110 12.5	100	110.0	13.5
SDA 100 113 12.5	100	113.0	13.5
SDA 100 120 13.5	100	120.0	14.5
SDA 110 120 13.5	110	120.0	14.5
SDA 110 125 12	110	125.0	13.0
SDA 110 130 11.5	110	130.0	12.5
SDA 120 135 11.5	120	135.0	12.5
SDA 120 140 11.5	120	140.0	12.5
SDA 120 140 15	120	140.0	16.0
SDA 130 145 12	130	145.0	13.0
SDA 135 150 12	135	150.0	13.0
SDA 140 155 12	140	155.0	13.0

# SDAN



SDAN

The seal type Aston Seals SDAN is the natural further development of the SDA seal. It is a high performance all purpose lipseal which combines the advantage of a highly elastic rubber and the abrasion resistance of polyurethane.

This seal is mainly used with high pressure and the backup ring offsets large gaps without extrusion.

Wear and dry run are largely prevented by additional lubricant retained within the gap created by the secondary lip. In some cases this second sealing lip may even act as a substitute for a costly tandem sealing system when complete sealing under certain working conditions can only be achieved by two seals placed one behind the other in separate housing.

The energizing O-Ring guarantees a good

sealing performance in the low pressure range.

The material used to produce this seal is a polyurethane compound that ensures excellent properties on wear-resistance, extended service life and resistance against extrusion.

- Very high resistance against extrusion (backup ring)
- Good sealing performance as well as at low pressure
- Extended service life
- Excellent wear-resistance
- Good temperature resistance
- Insensitive to pressure fluctuation
- Easy installation without expensive auxiliaries

## MATERIAL

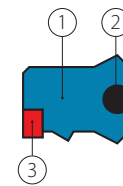

① **Type** Polyurethane  
**Designation** SEALPUR 93  
**Hardness** 93 °ShA

② **Type** Nitril Rubber NBR  
**Designation** RUBSEAL 70  
**Hardness** 70 °ShA

③ **Type** Acetal resin  
**Designation** BEARITE

## FIELD OF APPLICATION

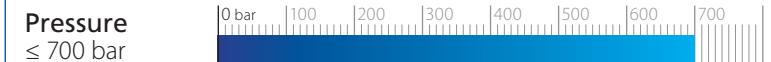

**Fluids** Hydraulic oils (mineral oil based)  
 For other fluids contact our technical department

## SURFACE ROUGHNESS

**Dynamic surface** Ra ≤ 0.3 µm Rt ≤ 2.5 µm  
**Static surface** Ra ≤ 1.6 µm Rt ≤ 6.3 µm

## GAP DIMENSION "g"

The largest gap dimension appearing in operation on the non-pressurised side:

200 bar	0.80 mm	500 bar	0.40 mm
300 bar	0.65 mm	600 bar	0.33 mm
400 bar	0.50 mm	700 bar	0.25 mm

## LEAD-IN CHAMFERS

d	Smin
less 100	5 mm
100÷200	7 mm
over 200	10 mm

To avoid damaging the sealing lips during installation, housing must have rounded chamfers. Sharp edges and burrs within the installation area of the seal must be removed.

The above data are maximum values, they may be maintained for short periods and can not be used at the same time simultaneously.



# SDAN

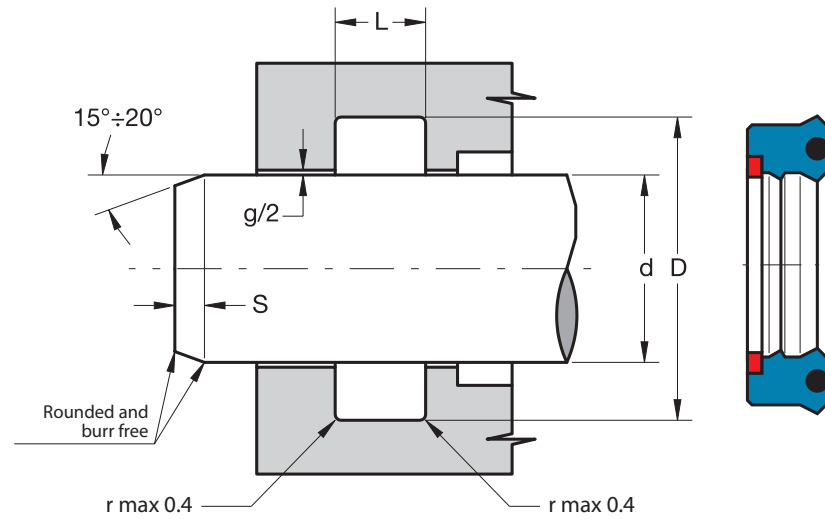

Part.	d <sup>f7</sup>	D <sup>H10</sup>	L <sup>+0.25</sup>
<b>SDAN 40 50 7</b>	40	50.0	8.0
<b>SDAN 50 59 10</b>	50	59.0	11.0
<b>SDAN 50 65 11.5</b>	50	65.0	12.5
<b>SDAN 60 75 11.5</b>	60	75.0	12.5
<b>SDAN 63 78 11.5</b>	63	78.0	12.5
<b>SDAN 70 85 11.5</b>	70	85.0	12.5
<b>SDAN 80 95 11.5</b>	80	95.0	12.5
<b>SDAN 90 105 11.5</b>	90	105.0	12.5
<b>SDAN 110 130 14.5</b>	110	130.0	15.5

S

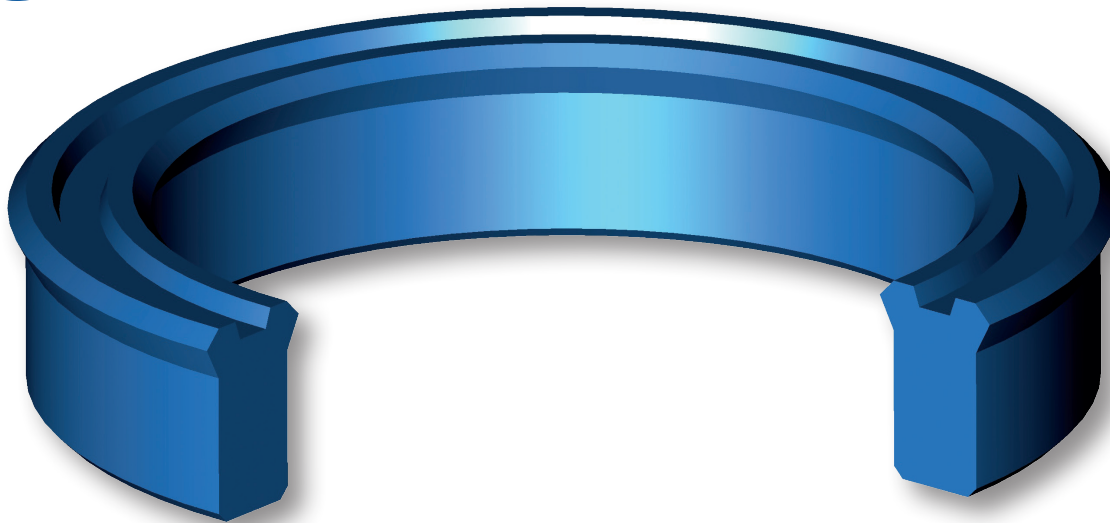

**MATERIAL**

	<b>Type</b> Polyurethane	<b>Designation</b> SEALPUR 93	<b>Hardness</b> 93 °ShA
--	-----------------------------	----------------------------------	----------------------------

**FIELD OF APPLICATION**

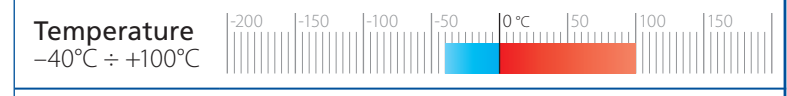
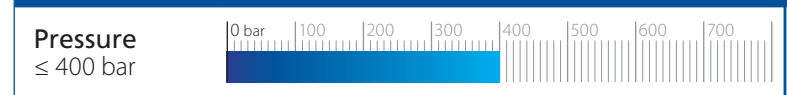

**Fluids**  
Hydraulic oils (mineral oil based)  
For other fluids contact our technical department

**SURFACE ROUGHNESS**

<b>Dynamic surface</b>	Ra ≤ 0.3 µm	Rt ≤ 2.5 µm
<b>Static surface</b>	Ra ≤ 1.6 µm	Rt ≤ 6.3 µm

**GAP DIMENSION "g"**

The largest gap dimension appearing in operation on the non-pressurised side:

50 bar	1.20 mm	300 bar	0.25 mm
100 bar	0.80 mm	400 bar	0.17 mm
200 bar	0.40 mm		

**LEAD-IN CHAMFERS**

d	Smin
less 100	5 mm
100÷200	7 mm
over 200	10 mm

To avoid damaging the sealing lips during installation, housing must have rounded chamfers. Sharp edges and burrs within the installation area of the seal must be removed.

The above data are maximum values, they may be maintained for short periods and can not be used at the same time simultaneously.

Thanks to its semicompact profile, the rod seal type Aston Seals S assures a good sealing performance as well as at low pressure.

It's designed to be less sensitive to pressure fluctuations than typical "U" seals.

The material used to produce this seal is a polyurethane compound that ensures excellent properties on wear-resistance, extended service life and resistance against extrusion.

- Good sealing performance as well as at low pressure
- Extended service life
- Excellent wear-resistance

- Good temperature resistance
- Insensitive to pressure fluctuation
- Easy installation without expensive auxiliaries

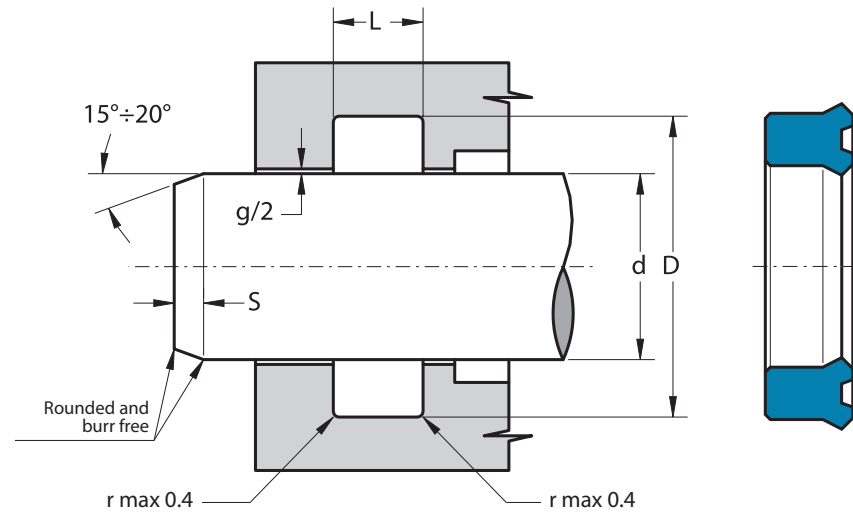

Part.	d <sup>f7</sup>	D <sup>H10</sup>	L <sup>+0.25</sup>
<b>S 8 13 4</b>	8	13.0	4.5
<b>S 12 16 3.5</b>	12	16.0	4.0
<b>S 12 17 3.5</b>	12	17.0	4.0
<b>S 12 18 4.5</b>	12	18.0	5.0
<b>S 14 19 4.8</b>	14	19.0	5.3
<b>S 16 20 3.3</b>	16	20.0	3.8
<b>S 16 22 4</b>	16	22.0	4.5
<b>S 20 25 3.7</b>	20	25.0	4.5
<b>S 22 28 4.5</b>	22	28.0	5.0
<b>S 22 30 5.8</b>	22	30.0	6.3
<b>S 22 32 8</b>	22	32.0	9.0
<b>S 25 32 4</b>	25	32.0	5.0
<b>S 25 33 5.8</b>	25	33.0	6.3
<b>S 28 35 4</b>	28	35.0	4.5
<b>S 35 42 4.5</b>	35	42.0	5.0
<b>S 56 66 6.5</b>	56	66.0	7.5
<b>S 140 155.5 5.8</b>	140	155.5	6.3

Inch sizes

<b>S 3375 4375 0550</b>	85.7	111.1	15.0
-------------------------	------	-------	------

A



**MATERIAL**

	<b>Type</b>	<b>Designation</b>	<b>Hardness</b>
	Polyurethane	SEALPUR 93	93 °ShA

**FIELD OF APPLICATION**

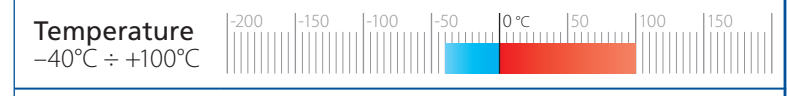
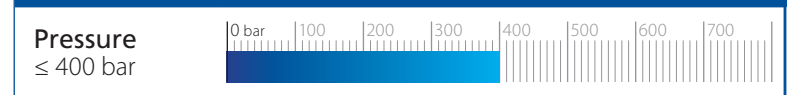

**Fluids** Hydraulic oils (mineral oil based)  
For other fluids contact our technical department

**SURFACE ROUGHNESS**

<b>Dynamic surface</b>	Ra ≤ 0.3 µm	Rt ≤ 2.5 µm
<b>Static surface</b>	Ra ≤ 1.6 µm	Rt ≤ 6.3 µm

**GAP DIMENSION "g"**

The largest gap dimension appearing in operation on the non-pressurised side:

50 bar	1.20 mm	300 bar	0.25 mm
100 bar	0.80 mm	400 bar	0.17 mm
200 bar	0.40 mm		

**LEAD-IN CHAMFERS**

d	Smin
less 100	5 mm
100÷200	7 mm
over 200	10 mm

To avoid damaging the sealing lips during installation, housing must have rounded chamfers. Sharp edges and burrs within the installation area of the seal must be removed.

The above data are maximum values, they may be maintained for short periods and can not be used at the same time simultaneously.

The rod seal type Aston Seals A assures a good reaction against shock pressure peaks and low friction in the low pressure range.

The asymmetric lips are designed to differentiate the behaviour of the lips on the static and dynamic surfaces: the static lip is flexible and more sensitive to pressure fluctuations; the dynamic lip is shorter and stronger to concentrate load against the dynamic surface.

The material used to produce this seal is a polyurethane compound that ensures excellent properties on wear-resistance, extended service life and resistance against extrusion.

- Extended service life
- High resistance against extrusion
- Excellent wear-resistance
- Good temperature resistance
- Insensitive to structural deflections
- Easy installation without expensive auxiliaries

A

A

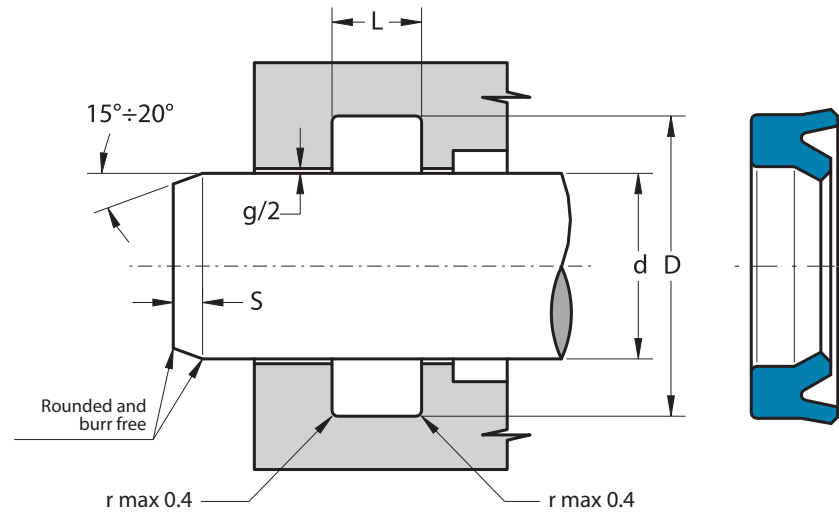

Part.	d <sup>f7</sup>	D <sup>H10</sup>	L <sup>+0.25</sup>
A 4 8 3	4	8.0	3.5
A 6 11 4	6	11.0	4.5
A 6 11 5.5	6	11.0	6.0
A 8 16 5.8	8	16.0	6.3
A 10 18 5.8	10	18.0	6.3
A 10 20 7	10	20.0	8.0
A 11 17 4.5	11	17.0	5.0
A 12 17 3.5	12	17.0	4.0
A 12 20 5.8	12	20.0	6.3
A 12 22 7	12	22.0	8.0
A 14 22 5.8	14	22.0	6.3
A 15 21 5	15	21.0	5.5
A 15 23 5.8	15	23.0	6.3
A 16 20.6 3.3	16	20.6	3.6
A 16 22 5	16	22.0	5.5
A 16 24 5.8	16	24.0	6.3
A 18 24 4.7	18	24.0	5.2
A 18 26 5	18	26.0	5.5
A 18 26 5.8	18	26.0	6.3
A 18 28 7	18	28.0	8.0
A 20 26 5	20	26.0	5.5
A 20 28 5.8	20	28.0	6.3
A 20 28 6	20	28.0	7.0
A 20 28 7	20	28.0	8.0

Part.	d <sup>f7</sup>	D <sup>H10</sup>	L <sup>+0.25</sup>
A 20 30 7	20	30.0	8.0
A 22 30 5	22	30.0	5.5
A 22 30 5.8	22	30.0	6.3
A 22 32 7	22	32.0	8.0
A 24 30 4.5	24	30.0	5.0
A 24 34 7	24	34.0	8.0
A 25 32 6	25	32.0	7.0
A 25 33 5	25	33.0	5.5
A 25 33 5.8	25	33.0	6.3
A 25 33 6.3	25	33.0	7.0
A 25 33 7	25	33.0	8.0
A 25 35 7	25	35.0	8.0
A 27 35 5.8	27	35.0	6.3
A 28 36 5.8	28	36.0	6.3
A 28 38 7	28	38.0	8.0
A 28 40 8.5	28	40.0	9.5
A 30 38 5.8	30	38.0	6.3
A 30 38 8	30	38.0	9.0
A 30 40 5.8	30	40.0	6.3
A 30 40 7	30	40.0	8.0
A 30 40 9.5	30	40.0	10.5
A 30 43 9	30	43.0	10.0
A 32 37 2.6	32	37.0	3.0
A 32 40 5.8	32	40.0	6.3

Part.	d <sup>f7</sup>	D <sup>H10</sup>	L <sup>+0.25</sup>
A 32 40 8	32	40.0	9.0
A 32 42 7	32	42.0	8.0
A 32 42 10	32	42.0	11.0
A 32 45 10	32	45.0	11.0
A 32 47 10	32	47.0	11.0
A 32 48 10	32	48.0	11.0
A 33 43 10	33	43.0	11.0
A 34 41 5	34	41.0	5.5
A 35 43 5.8	35	43.0	6.3
A 35 43 8	35	43.0	9.0
A 35 45 7	35	45.0	8.0
A 35 45 10	35	45.0	11.0
A 35 46 8	35	46.0	9.0
A 36 46 7	36	46.0	8.0
A 36 48 8	36	48.0	9.0
A 36 48 11	36	48.0	12.0
A 37 47 7	37	47.0	8.0
A 38 44.5 4.7	38	44.5	5.3
A 38 45 5	38	45.0	5.5
A 39 50 10	39	50.0	11.0
A 40 48 4	40	48.0	4.5
A 40 48 5.8	40	48.0	6.3
A 40 48 8	40	48.0	9.0
A 40 50 7	40	50.0	8.0

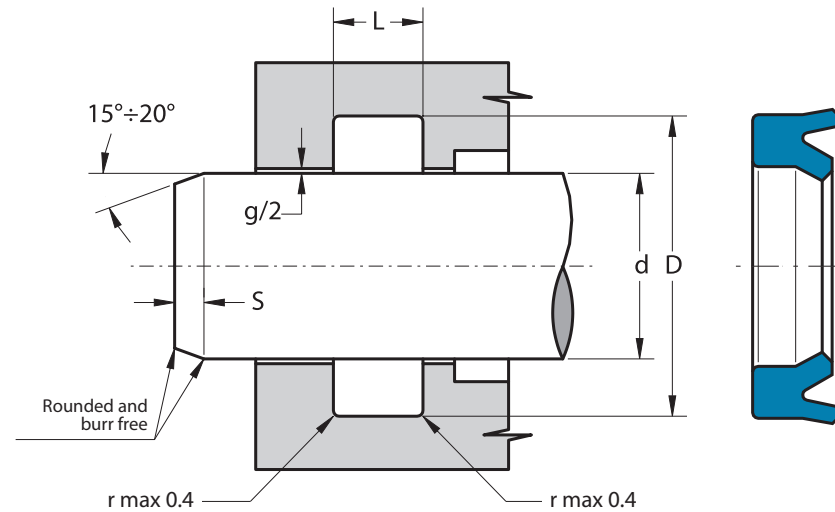

Part.	d <sup>f7</sup>	D <sup>H10</sup>	L <sup>+0.25</sup>
A 40 50 10	40	50.0	11.0
A 40 52 8	40	52.0	9.0
A 40 60 10	40	60.0	11.0
A 42 47 2.6	42	47.0	3.0
A 42 50 5.8	42	50.0	6.3
A 42 50 6	42	50.0	7.0
A 45 53 5.8	45	53.0	6.3
A 45 55 7	45	55.0	8.0
A 45 55 10	45	55.0	11.0
A 45 58 9	45	58.0	10.0
A 45 60 11.5	45	60.0	12.5
A 46 56 7	46	56.0	8.0
A 50 60 7	50	60.0	8.0
A 50 60 10	50	60.0	11.0
A 50 63 10	50	63.0	11.0
A 50 65 10	50	65.0	11.0
A 50 65 11.5	50	65.0	12.5
A 50 68 9	50	68.0	10.0
A 55 65 7	55	65.0	8.0
A 55 65 10	55	65.0	11.0
A 55 65 12	55	65.0	13.0
A 55 70 9.5	55	70.0	10.5
A 56 66 7	56	66.0	8.0
A 56 66 10	56	66.0	11.0

Part.	d <sup>f7</sup>	D <sup>H10</sup>	L <sup>+0.25</sup>
A 56 68 7	56	68.0	8.0
A 56 71 10	56	71.0	11.0
A 60 65.6 5.6	60	65.6	6.3
A 60 70 7	60	70.0	8.0
A 60 70 10	60	70.0	11.0
A 60 70 12	60	70.0	13.0
A 60 72 8	60	72.0	9.0
A 60 72 9	60	72.0	10.0
A 60 73 10	60	73.0	11.0
A 60 75 10	60	75.0	11.0
A 60 75 12	60	75.0	13.0
A 63 73 10	63	73.0	11.0
A 65 78 10	65	78.0	11.0
A 65 80 10	65	80.0	11.0
A 65 80 12	65	80.0	13.0
A 70 80 7	70	80.0	8.0
A 70 80 10	70	80.0	11.0
A 70 83 10	70	83.0	11.0
A 70 85 10	70	85.0	11.0
A 70 85 11	70	85.0	12.0
A 73 82.5 7	73	82.5	8.0
A 75 88 10	75	88.0	11.0
A 75 90 10	75	90.0	11.0
A 80 90 7	80	90.0	8.0

Part.	d <sup>f7</sup>	D <sup>H10</sup>	L <sup>+0.25</sup>
A 80 90 12	80	90.0	13.0
A 80 93 10	80	93.0	11.0
A 80 95 10	80	95.0	11.0
A 85 95 7.2	85	95.0	8.2
A 85 100 12	85	100.0	13.0
A 90 100 12	90	100.0	13.0
A 90 105 10	90	105.0	11.0
A 90 105 12	90	105.0	13.0
A 90 110 12	90	110.0	13.0
A 95 105 5	95	105.0	5.7
A 100 108 5	100	108.0	5.5
A 100 109.3 5.7	100	109.3	6.2
A 100 115 9	100	115.0	10.0
A 100 115 10.5	100	115.0	11.5
A 100 115 12	100	115.0	13.0
A 100 120 12.5	100	120.0	13.5
A 100 120 15	100	120.0	16.0
A 105 113 5	105	113.0	5.5
A 105 115 5.7	105	115.0	6.2
A 110 120 5.5	110	120.0	6.0
A 110 120 12	110	120.0	13.0
A 110 125 9.6	110	125.0	10.6
A 110 130 12	110	130.0	13.0
A 115 130 11	115	130.0	12.0

A

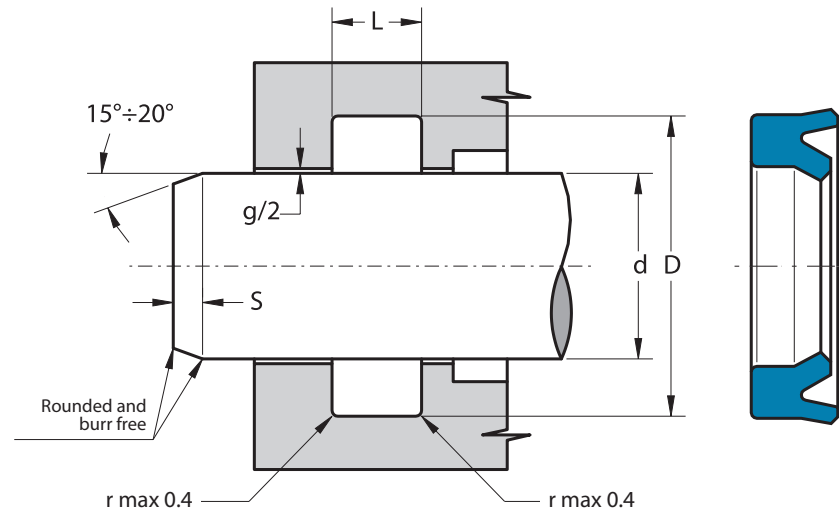

Part.	d <sup>f7</sup>	D <sup>H10</sup>	L <sup>+0.25</sup>
<b>A 120 128 5</b>	120	128.0	5.5
<b>A 120 140 15</b>	120	140.0	16.0
<b>A 125 145 12</b>	125	145.0	13.0
<b>A 130 138 5</b>	130	138.0	5.5
<b>A 130 145 14</b>	130	145.0	15.0
<b>A 140 150 6</b>	140	150.0	7.0
<b>A 140 150 11.5</b>	140	150.0	12.5
<b>A 155 165 6</b>	155	165.0	7.0
<b>A 160 185 19</b>	160	185.0	20.0
<b>A 165 175 6</b>	165	175.0	7.0
<b>A 180 200 14.5</b>	180	200.0	15.5
<b>A 200 210 6</b>	200	210.0	7.0
<b>A 200 220 14.5</b>	200	220.0	15.5
<b>A 216 226 6</b>	216	226.0	7.0
<b>A 238 258 15</b>	238	258.0	16.0
<b>A 239.5 260.5 16.5</b>	239.5	260.5	17.5
<b>A 240 260 15</b>	240	260.0	16.0
<b>A 265 295 19</b>	265	295.0	20.0

Inch sizes

<b>A 7000 8000 0765</b>	177.8	203.2	20.4
-------------------------	-------	-------	------

A

# AD



### MATERIAL

	<b>Type</b> Polyurethane	<b>Designation</b> SEALPUR 93	<b>Hardness</b> 93 °ShA
--	-----------------------------	----------------------------------	----------------------------

### FIELD OF APPLICATION

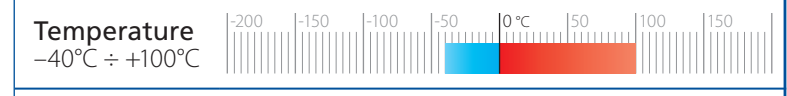
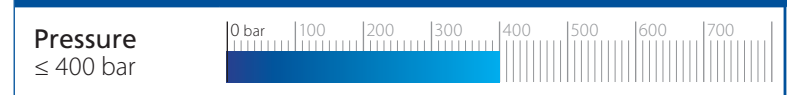

**Fluids** Hydraulic oils (mineral oil based)  
For other fluids contact our technical department

### SURFACE ROUGHNESS

<b>Dynamic surface</b>	Ra ≤ 0.3 µm	Rt ≤ 2.5 µm
<b>Static surface</b>	Ra ≤ 1.6 µm	Rt ≤ 6.3 µm

### GAP DIMENSION "g"

The largest gap dimension appearing in operation on the non-pressurised side:

50 bar	1.20 mm	300 bar	0.25 mm
100 bar	0.80 mm	400 bar	0.17 mm
200 bar	0.40 mm		

### LEAD-IN CHAMFERS

d	Smin
less 100	5 mm
100÷200	7 mm
over 200	10 mm

To avoid damaging the sealing lips during installation, housing must have rounded chamfers. Sharp edges and burrs within the installation area of the seal must be removed.

The above data are maximum values, they may be maintained for short periods and can not be used at the same time simultaneously.

The rod seal type Aston Seals AD assures a good reaction against shock pressure peaks and low friction in the low pressure range.

The asymmetric lips are designed to differentiate the behaviour of the lips on the static and dynamic surfaces: the static lip is flexible and more sensitive to pressure fluctuations; the dynamic lip is shorter and stronger to concentrate load against the dynamic surface.

Wear and dry run are largely prevented by additional lubricant retained within the gap created by the secondary lip.

The material used to produce this seal is a polyurethane compound that ensures

excellent properties on wear-resistance, extended service life and resistance against extrusion.

- Extended service life
- High resistance against extrusion
- Excellent wear-resistance
- Good temperature resistance
- Insensitive to structural deflections
- Easy installation without expensive auxiliaries



# AD

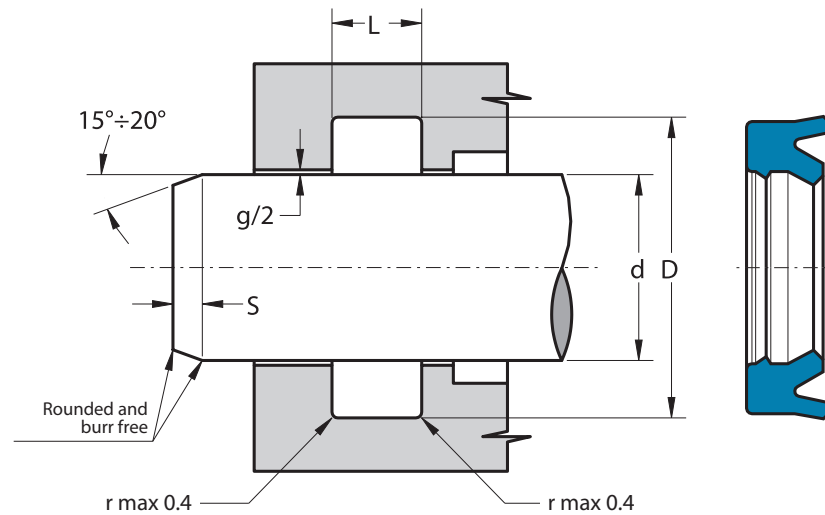

Part.	d <sup>f7</sup>	D <sup>H10</sup>	L <sup>+0.25</sup>
AD 5 10 3.5	5	10.0	4.0
AD 6 11 3.5	6	11.0	4.0
AD 7 12 4	7	12.0	4.5
AD 12 22 8	12	22.0	9.0
AD 16 24 5.8	16	24.0	6.3
AD 16 24 6	16	24.0	7.0
AD 20 26 5	20	26.0	5.5
AD 20 28 5.7	20	28.0	6.2
AD 20 28 6	20	28.0	7.0
AD 22 28 5.8	22	28.0	6.3
AD 22 30 5.8	22	30.0	6.3
AD 22 30 6	22	30.0	7.0
AD 25 33 5.5	25	33.0	6.0
AD 25 33 5.8	25	33.0	6.3
AD 25 33 6.5	25	33.0	7.5
AD 25 35 7	25	35.0	8.0
AD 26 36 10	26	36.0	11.0
AD 28 38 7.3	28	38.0	8.3
AD 28 38.7 3.7	28	38.7	4.2
AD 30 40 6	30	40.0	7.0
AD 30 40 7	30	40.0	8.0
AD 30 40 7.3	30	40.0	8.3
AD 30 40 10	30	40.0	11.0
AD 30 40.7 3.7	30	40.7	4.2

Part.	d <sup>f7</sup>	D <sup>H10</sup>	L <sup>+0.25</sup>
AD 30 42 11	30	42.0	12.0
AD 32 40 6.5	32	40.0	7.5
AD 32 41.53 7.9	32	41.53	8.9
AD 32 42 7.3	32	42.0	8.3
AD 32 45 10	32	45.0	11.0
AD 35 43 7	35	43.0	8.0
AD 35 45.7 3.7	35	45.7	4.2
AD 36 44 6	36	44.0	7.0
AD 36 46 7	36	46.0	8.0
AD 36 46 10	36	46.0	11.0
AD 38 48 8	38	48.0	9.0
AD 40 48 5.8	40	48.0	6.3
AD 40 49.52 9.5	40	49.52	10.5
AD 40 50 6	40	50.0	7.0
AD 40 50 7	40	50.0	8.0
AD 40 50 8	40	50.0	9.0
AD 40 50 10	40	50.0	11.0
AD 40 52 11	40	52.0	12.0
AD 40 55 10	40	55.0	11.0
AD 40 55.1 5.8	40	55.1	6.3
AD 42 50 5.8	42	50.0	6.3
AD 45 53 5.8	45	53.0	6.3
AD 45 55 6	45	55.0	7.0
AD 45 55 7	45	55.0	8.0

Part.	d <sup>f7</sup>	D <sup>H10</sup>	L <sup>+0.25</sup>
AD 45 55 10	45	55.0	11.0
AD 45 60 11.5	45	60.0	12.5
AD 45 60.1 5.8	45	60.1	6.3
AD 50 57 9	50	57.0	10.0
AD 50 57 10	50	57.0	11.0
AD 50 60 7	50	60.0	8.0
AD 50 60 10	50	60.0	11.0
AD 50 65 10	50	65.0	11.0
AD 50 65.1 5.8	50	65.1	6.3
AD 55 63 11.5	55	63.0	12.5
AD 55 63.15 13	55	63.15	14.0
AD 55 65 8.5	55	65.0	9.5
AD 55 65 10	55	65.0	11.0
AD 56 71 8.5	56	71.0	9.5
AD 56 71 11.5	56	71.0	12.5
AD 60 68 8	60	68.0	9.0
AD 60 69.3 5.5	60	69.3	6.2
AD 60 70 7	60	70.0	8.0
AD 60 70 14	60	70.0	15.0
AD 60 75 12	60	75.0	13.0
AD 63 73 6	63	73.0	7.0
AD 63 78 10	63	78.0	11.0
AD 63 78 11.5	63	78.0	12.5
AD 65 73 9	65	73.0	10.0

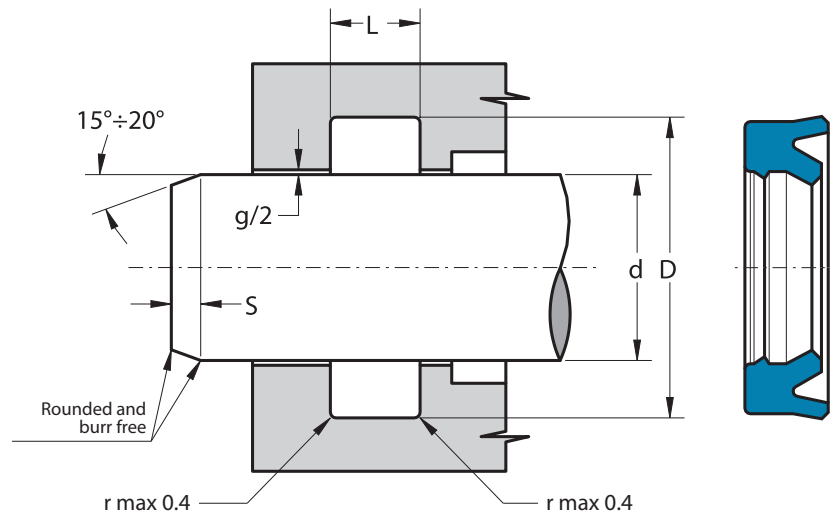

Part.	d <sup>f7</sup>	D <sup>H10</sup>	L <sup>+0.25</sup>
AD 65 73 11.5	65	73.0	12.5
AD 65 75 6	65	75.0	7.0
AD 65 77 9	65	77.0	10.0
AD 65 80 12	65	80.0	13.0
AD 70 80 11.5	70	80.0	12.5
AD 70 80 12	70	80.0	13.0
AD 70 85 11.5	70	85.0	12.5
AD 75 83 11.5	75	83.0	12.5
AD 75 85 11.5	75	85.0	12.5
AD 78 86.15 13	78	86.15	14.0
AD 78 88 14	78	88.0	15.0
AD 80 90 7	80	90.0	8.0
AD 80 90 8	80	90.0	9.0
AD 80 95 11.5	80	95.0	12.5
AD 85 93 10	85	93.0	11.0
AD 85 93 11.5	85	93.0	12.5
AD 88.9 101.6 9.5	88.9	101.6	10.5
AD 90 98 11.5	90	98.0	12.5
AD 90 100 11.5	90	100.0	12.5

Part.	d <sup>f7</sup>	D <sup>H10</sup>	L <sup>+0.25</sup>
AD 90 105 11.5	90	105.0	12.5
AD 90 110 14	90	110.0	15.0
AD 95 103 11.5	95	103.0	12.5
AD 99 109 14	99	109.0	15.0
AD 100 110 10	100	110.0	11.0
AD 100 110 11.5	100	110.0	12.5
AD 100 115 12	100	115.0	13.0
AD 100 120 12	100	120.0	13.0
AD 105 113 11.5	105	113.0	12.5
AD 105 113.15 13	105	113.15	14.0
AD 105 115 11.5	105	115.0	12.5
AD 105 120 10	105	120.0	11.0
AD 110 120 10.5	110	120.0	11.5
AD 115 123 11.5	115	123.0	12.5
AD 115 125 12	115	125.0	13.0
AD 118 133 9.8	118	133.0	10.8
AD 120 130 14	120	130.0	15.0
AD 125 133 11.5	125	133.0	12.5
AD 125 135 11	125	135.0	12.0

Part.	d <sup>f7</sup>	D <sup>H10</sup>	L <sup>+0.25</sup>
AD 135 143 11.5	135	143.0	12.5
AD 135 150 11.5	135	150.0	12.5
AD 141 151 14	141	151.0	15.0
AD 145 160 12	145	160.0	13.0
AD 150 160 11	150	160.0	12.0
AD 155 163 11.5	155	163.0	12.5
AD 160 170 11.5	160	170.0	12.5
AD 162 172 14	162	172.0	15.0
AD 175 185 11	175	185.0	12.0
AD 180 190 10	180	190.0	11.0
AD 183 193 14	183	193.0	15.0
AD 207 217 14	207	217.0	15.0

Inch sizes

AD 1250 1750 0250	31.75	44.45	7.0
AD 1500 2000 0335	38.1	50.8	9.5
AD 3500 4250 0620	88.9	107.95	16.75



# ADA



ADA

## MATERIAL

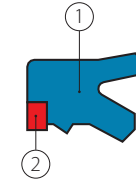

① Type	Polyurethane
Designation	SEALPUR 93
Hardness	93 °ShA
② Type	Acetal resin
Designation	BEARITE

## FIELD OF APPLICATION

Pressure ≤ 700 bar	
Speed ≤ 0.5 m/s	
Temperature -40°C ÷ +100°C	
Fluids	Hydraulic oils (mineral oil based) For other fluids contact our technical department

## SURFACE ROUGHNESS

Dynamic surface	Ra ≤ 0.3 µm	Rt ≤ 2.5 µm
Static surface	Ra ≤ 1.6 µm	Rt ≤ 6.3 µm

## GAP DIMENSION "g"

The largest gap dimension appearing in operation on the non-pressurised side:

200 bar	0.80 mm	500 bar	0.40 mm
300 bar	0.65 mm	600 bar	0.33 mm
400 bar	0.50 mm	700 bar	0.25 mm

## LEAD-IN CHAMFERS

d	Smin
less 100	5 mm
100÷200	7 mm
over 200	10 mm

To avoid damaging the sealing lips during installation, housing must have rounded chamfers. Sharp edges and burrs within the installation area of the seal must be removed.

The above data are maximum values, they may be maintained for short periods and can not be used at the same time simultaneously.

This seal is mainly used with high pressure and the backup ring offsets large gaps without extrusion.

The asymmetric lips are designed to differentiate the behaviour of the lips on the static and dynamic surfaces: the static lip is flexible and more sensitive to pressure fluctuations; the dynamic lip is shorter and stronger to concentrate load against the dynamic surface.

Wear and dry run are largely prevented by additional lubricant retained within the gap created by the secondary lip. In some cases this second sealing lip may even act as a substitute for a costly tandem sealing system when complete sealing under certain working conditions can only be achieved by two seals placed one behind the other in separate

housing.

The material used to produce this seal is a polyurethane compound that ensures excellent properties on wear-resistance, extended service life and resistance against extrusion.

- Very high resistance against extrusion (backup ring)
- Extended service life
- Excellent wear-resistance
- Good temperature resistance
- Insensitive to structural deflections
- Easy installation without expensive auxiliaries

# ADA

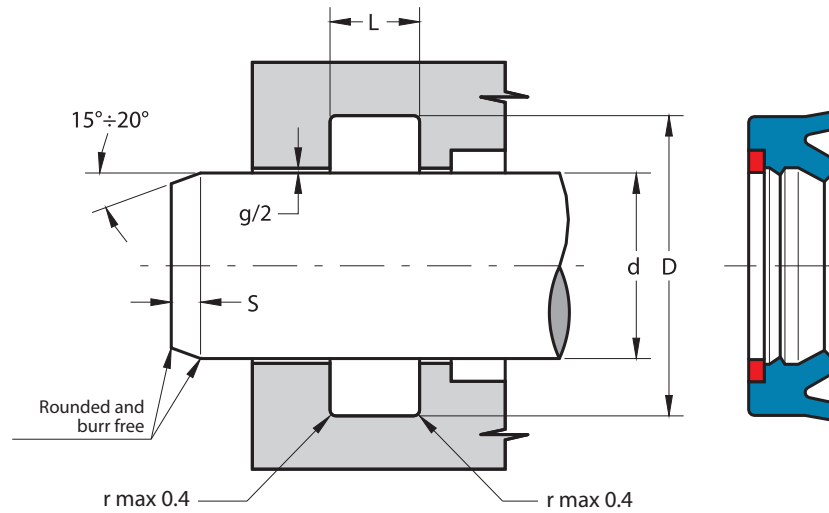

Part.	d <sup>f7</sup>	D <sup>H10</sup>	L <sup>+0.25</sup>
ADA 40 55 11.5	40	55.0	12.5
ADA 60 68 13	60	68.0	14.0
ADA 75 90 10	75	90.0	11.0
ADA 78 86 13	78	86.0	14.0
ADA 80 95 11.5	80	95.0	12.5
ADA 90 105 11.5	90	105.0	12.5
ADA 90 105 12	90	105.0	13.0
ADA 97 105 13	97	105.0	14.0
ADA 105 125 14.5	105	125.0	15.5
ADA 110 130 15	110	130.0	16.0
ADA 115 140 15	115	140.0	16.0
ADA 118 126 13	118	126.0	14.0
ADA 143 151 13	143	151.0	14.0
ADA 180 195 14	180	195.0	15.0

# AR

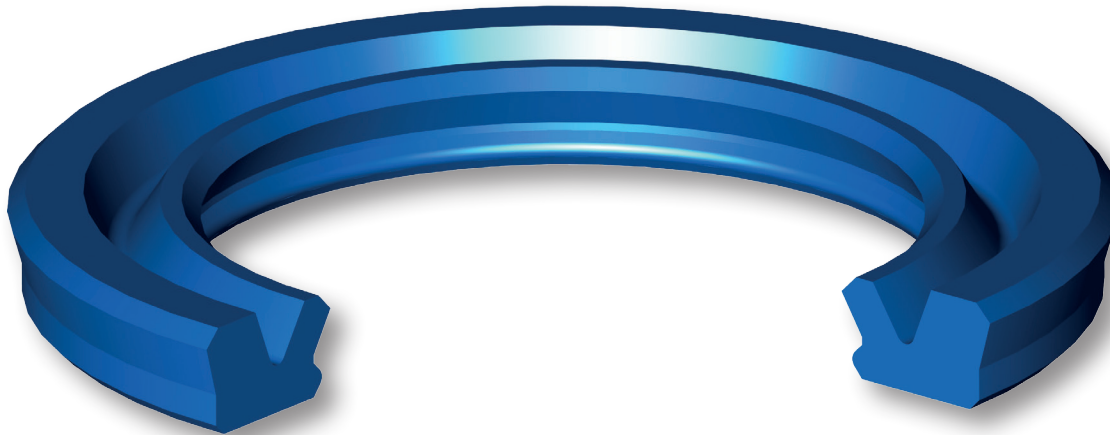

AR

## MATERIAL



Type	Designation	Hardness
Polyurethane	SEALPUR 93	93 °ShA

## FIELD OF APPLICATION

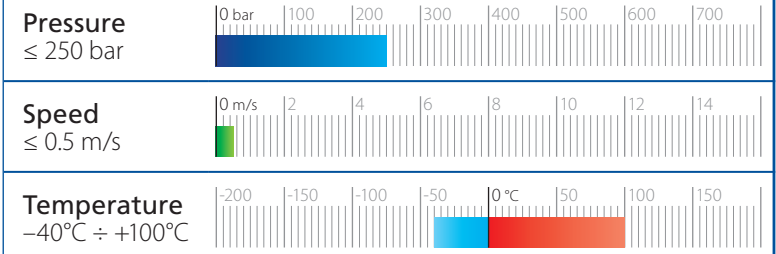

**Fluids** Hydraulic oils (mineral oil based)  
For other fluids contact our technical department

## SURFACE ROUGHNESS

<b>Dynamic surface</b>	Ra ≤ 0.3 µm	Rt ≤ 2.5 µm
<b>Static surface</b>	Ra ≤ 1.6 µm	Rt ≤ 6.3 µm

## GAP DIMENSION "g"

The largest gap dimension appearing in operation on the non-pressurised side:

100 bar	0.80 mm	200 bar	0.40 mm
150 bar	0.60 mm	250 bar	0.32 mm

## LEAD-IN CHAMFERS

d	Smin
less 100	5 mm
100÷200	7 mm
over 200	10 mm

To avoid damaging the sealing lips during installation, housing must have rounded chamfers. Sharp edges and burrs within the installation area of the seal must be removed.

The above data are maximum values, they may be maintained for short periods and can not be used at the same time simultaneously.

The Aston Seals AR is a seal with asymmetric lips designed for light and medium duty applications where spaces and friction need to be low.

It can be used either as a single acting seal or, in presence of fast and high pressure variations, in tandem configuration as a "secondary" seal behind a PTFE one.

It is used in the same housing normally destined to PTFE seal of which has similar dimensional characteristics but, compared to it, better sealing capabilities, greater easy installation and lower cost.

The seal is made of a polyurethane compound that ensures excellent properties on wear-

resistance, extended service life and resistance against extrusion.

- Good sealing performance
- Low cost solution
- Easy installation
- Designed to snap fit into its housing
- Simple groove design and space-saving construction
- Excellent wear-resistance
- Extended service life
- Good temperature resistance

# AR

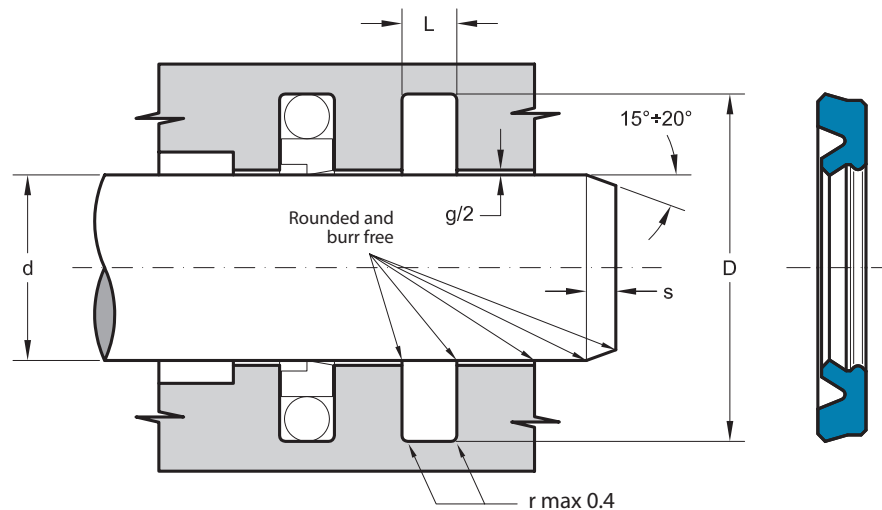

Part.	d <sup>f7</sup>	D <sup>H10</sup>	L <sup>+0.25</sup>
AR 20 31 4.2	20	31.0	4.2
AR 25 36 4.2	25	36.0	4.2
AR 30 41 4.2	30	41.0	4.2
AR 40 51 4.2	40	51.0	4.2
AR 50 61 4.2	50	61.0	4.2

# ARA

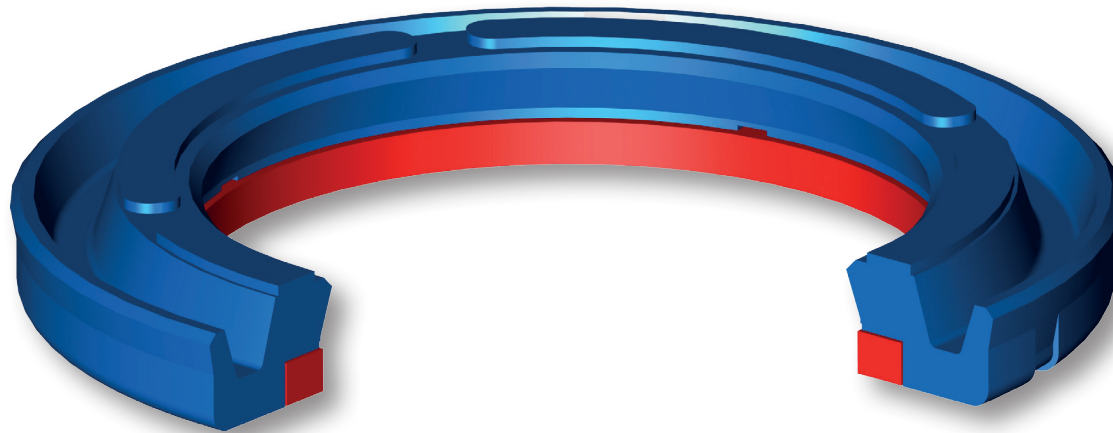

ARA

The Aston Seals ARA is a buffer seal designed for medium and heavy duty applications where spaces and friction need to be low.

It can be used either as a single acting seal or in tandem configuration as a "primary" seal.

Radial notches on the back facilitates back pumping and pressure relieve capability avoiding the risk of tipping.

Radial slots on the front avoid risk of suction.

The backup ring provides a very high resistance against extrusion in presence of pressure loads.

It is used in the same housing normally destined to PTFE seal of which has similar dimensional characteristics but, compared to

it, better sealing capabilities and greater easy installation.

- Very high resistance against extrusion
- Good sealing capability
- Designed with relief notches to prevent pressure trapping
- Interchangeable with common PTFE buffer seal housings
- Easy installation
- Excellent wear-resistance
- Extended service life
- Good temperature resistance

## MATERIAL



① **Type** Polyurethane  
**Designation** SEALPUR 93  
**Hardness** 93 °ShA

② **Type** Acetal resin  
**Designation** BEARITE

## FIELD OF APPLICATION

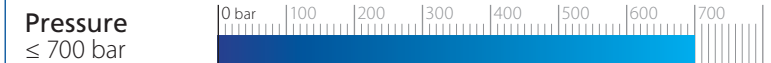

**Fluids** Hydraulic oils (mineral oil based)  
 For other fluids contact our technical department

## SURFACE ROUGHNESS

**Dynamic surface** Ra ≤ 0.3 μm Rt ≤ 2.5 μm  
**Static surface** Ra ≤ 1.6 μm Rt ≤ 6.3 μm

## GAP DIMENSION "g"

The largest gap dimension appearing in operation on the non-pressurised side:

200 bar	0.80 mm	500 bar	0.40 mm
300 bar	0.65 mm	600 bar	0.33 mm
400 bar	0.50 mm	700 bar	0.25 mm

## LEAD-IN CHAMFERS

d	Smin
less 100	5 mm
100÷200	7 mm
over 200	10 mm

To avoid damaging the sealing lips during installation, housing must have rounded chamfers. Sharp edges and burrs within the installation area of the seal must be removed.

The above data are maximum values, they may be maintained for short periods and can not be used at the same time simultaneously.



# ARA

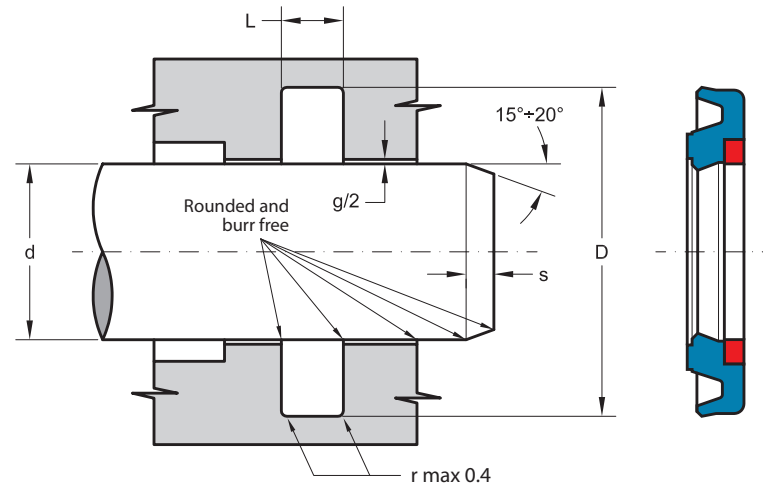

Part.	d <sup>f7</sup>	D <sup>H10</sup>	L <sup>+0.25</sup>
<b>ARA 40 55.1 6.3</b>	40	55.1	6.3
<b>ARA 45 60.1 6.3</b>	45	60.1	6.3
<b>ARA 50 65.1 6.3</b>	50	65.1	6.3
<b>ARA 56 71.1 6.3</b>	56	71.1	6.3
<b>ARA 60 75.1 6.3</b>	60	75.1	6.3
<b>ARA 63 78.1 6.3</b>	63	78.1	6.3
<b>ARA 70 85.1 6.3</b>	70	85.1	6.3
<b>ARA 80 95.1 6.3</b>	80	95.1	6.3
<b>ARA 90 105.1 6.3</b>	90	105.1	6.3
<b>ARA 100 115.1 6.3</b>	100	115.1	6.3

# SHT



The Aston Seals SHT is the optimal solution for industrial hydraulic applications. It can be used in the same housing normally destined to PTFE seal of which has similar technical and dimensional characteristics but, compared to it, better sealing capabilities, greater ease of installation and a lower cost.

The SHT, composed of a high resistance polymer element on the dynamic side and an O-Ring as energizing component on the static side, can be used:

- individually
- in tandem: preferable solution in the presence of rapid and high pressure variations.
- Good sealing performance

- Low cost compared to the corresponding PTFE seal
- Easy installation
- Low friction and no tendency of stick-slip
- Returns to the size immediately after assembly
- Simple groove design and space-saving construction
- Excellent wear-resistance
- High resistance against extrusion
- Extended service life
- Good temperature resistance

## MATERIAL

	① Type	Thermoplastic polyester resin
	Designation	SEALITE 55
	Hardness	55 °ShD
	② Type	Nitril Rubber NBR
	Designation	RUBSEAL 70
	Hardness	70 °ShA

## FIELD OF APPLICATION

Pressure	0 bar	100	200	300	400	500	600	700	
≤ 500 bar									

Speed	0 m/s	2	4	6	8	10	12	14	
≤ 0.5 m/s (100°C)									

Speed	0 m/s	2	4	6	8	10	12	14	
≤ 1 m/s (80°C)									

Temperature	-200	-150	-100	-50	0 °C	50	100	150	
-30°C ÷ +100°C									

**Fluids** Hydraulic oils (mineral oil based)  
For other fluids contact our technical department

## SURFACE ROUGHNESS

Dynamic surface	Ra ≤ 0.3 μm	Rt ≤ 2.5 μm
Static surface	Ra ≤ 1.6 μm	Rt ≤ 6.3 μm

## GAP DIMENSION "g"

The largest gap dimension appearing in operation on the non-pressurised side:

L	100 bar	200 bar	300 bar	400 bar
2.2	0.70	0.45	0.35	0.30
3.2	0.80	0.50	0.40	0.30
4.2	0.80	0.50	0.40	0.35
6.3	0.90	0.55	0.45	0.35
8.1	1.10	0.70	0.50	0.40

$$> 400 \text{ bar} \Rightarrow g_{\max} = H8/f8$$

To avoid damaging the sealing lips during installation, housing must have rounded chamfers. Sharp edges and burrs within the installation area of the seal must be removed.

The above data are maximum values, they may be maintained for short periods and can not be used at the same time simultaneously.

# SHT

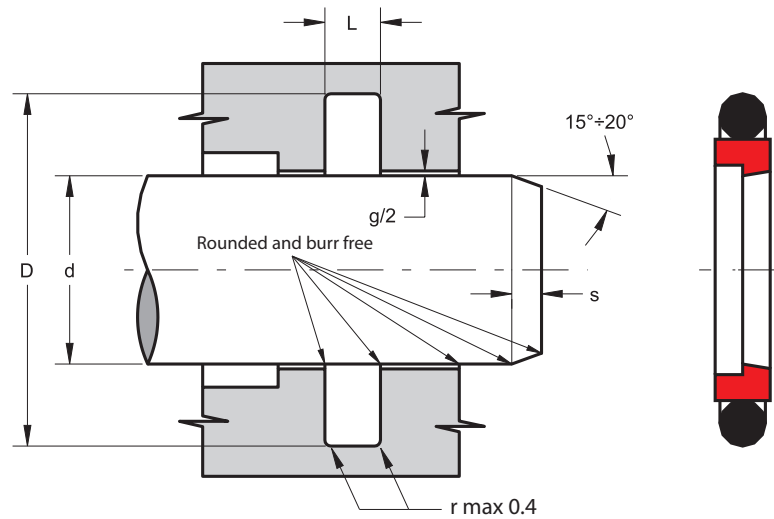

Part.	d <sup>h9</sup>	D <sup>H10</sup>	L <sup>+0.2</sup>	S	OR
<b>SHT 10 14.9 2.2</b>	10	14.9	2.2	2.0	013
<b>SHT 14 18.9 2.2</b>	14	18.9	2.2	2.0	016
<b>SHT 16 20.9 2.2</b>	16	20.9	2.2	2.0	017
<b>SHT 18 22.9 2.2</b>	18	22.9	2.2	2.0	018
<b>SHT 20 27.3 3.2</b>	20	27.3	3.2	2.5	118
<b>SHT 20 30.7 4.2</b>	20	30.7	4.2	3.5	214
<b>SHT 22 32.7 4.2</b>	22	32.7	4.2	3.5	215
<b>SHT 24 34.7 4.2</b>	24	34.7	4.2	3.5	216
<b>SHT 25 32.3 3.2</b>	25	32.3	3.2	2.5	122
<b>SHT 25 35.7 4.2</b>	25	35.7	4.2	3.5	217
<b>SHT 30 37.3 3.2</b>	30	37.3	3.2	2.5	125
<b>SHT 30 40.7 4.2</b>	30	40.7	4.2	3.5	220
<b>SHT 32 39.3 3.2</b>	32	39.3	3.2	2.5	126
<b>SHT 32 42.7 4.2</b>	32	42.7	4.2	3.5	221
<b>SHT 35 45.7 4.2</b>	35	45.7	4.2	3.5	222
<b>SHT 36 46.7 4.2</b>	36	46.7	4.2	3.5	223
<b>SHT 40 50.7 4.2</b>	40	50.7	4.2	3.5	224

Part.	d <sup>h9</sup>	D <sup>H10</sup>	L <sup>+0.2</sup>	S	OR
<b>SHT 40 55.1 6.3</b>	40	55.1	6.3	5.0	327
<b>SHT 45 55.7 4.2</b>	45	55.7	4.2	3.5	830
<b>SHT 45 60.1 6.3</b>	45	60.1	6.3	5.0	329
<b>SHT 50 60.7 4.2</b>	50	60.7	4.2	3.5	833
<b>SHT 50 65.1 6.3</b>	50	65.1	6.3	5.0	331
<b>SHT 56 66.7 4.2</b>	56	66.7	4.2	3.5	229
<b>SHT 57 72.1 6.3</b>	57	72.1	6.3	5.0	333
<b>SHT 60 70.7 4.2</b>	60	70.7	4.2	3.5	839
<b>SHT 60 75.1 6.3</b>	60	75.1	6.3	5.0	334
<b>SHT 70 80.7 4.2</b>	70	80.7	4.2	3.5	846
<b>SHT 70 85.1 6.3</b>	70	85.1	6.3	5.0	337
<b>SHT 75 90.1 6.3</b>	75	90.1	6.3	5.0	339
<b>SHT 78 93.1 6.3</b>	78	93.1	6.3	5.0	339
<b>SHT 80 95.1 6.3</b>	80	95.1	6.3	5.0	340
<b>SHT 90 105.1 6.3</b>	90	105.1	6.3	5.0	343
<b>SHT 100 115.1 6.3</b>	100	115.1	6.3	5.0	346
<b>SHT 110 125.1 6.3</b>	110	125.1	6.3	5.0	350

# SGA

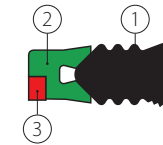

MATERIAL	
① Type	Nitril Rubber NBR
Designation	RUBSEAL 75
Hardness	75 °ShA
② Type	Thermoplastic polyester resin
Designation	SEALITE 63
Hardness	63 °ShD
③ Type	Acetal resin
Designation	BEARITE

### FIELD OF APPLICATION

Pressure ≤ 700 bar	
Speed ≤ 0.5 m/s	
Temperature -40°C ÷ +110°C	
Fluids	Hydraulic oils (mineral oil based) For other fluids contact our technical department

### SURFACE ROUGHNESS

Dynamic surface	Ra ≤ 0.3 μm	Rt ≤ 2.5 μm
Static surface	Ra ≤ 1.6 μm	Rt ≤ 6.3 μm

### LEAD-IN CHAMFERS

d	Smin
less 100	5 mm
100÷200	7 mm
over 200	10 mm

To avoid damaging the sealing lips during installation, housing must have rounded chamfers. Sharp edges and burrs within the installation area of the seal must be removed.

The above data are maximum values, they may be maintained for short periods and can not be used at the same time simultaneously.

The rod seal type Aston Seals SGA is composed of:

- A sealing rubber element with low permanent deformation which assures good sealing performance. Multiple sealing lips ensure perfect fluid control and concentrate load against the dynamic surface. The cavities keep small quantities of fluid reducing friction and wear.
- A support ring contoured to suit the main sealing rubber element. The special geometry assures that pressure loads the "V" shape
- An anti-extrusion ring which assures high pressure loads without any risk of extrusion.
- Very high resistance against extrusion

- Perfect fluid control
- Extended service life
- Excellent wear-resistance
- Good mechanical stability at high temperature
- Insensitive to pressure fluctuation and vibrations
- Easy installation without expensive auxiliaries

# SGA

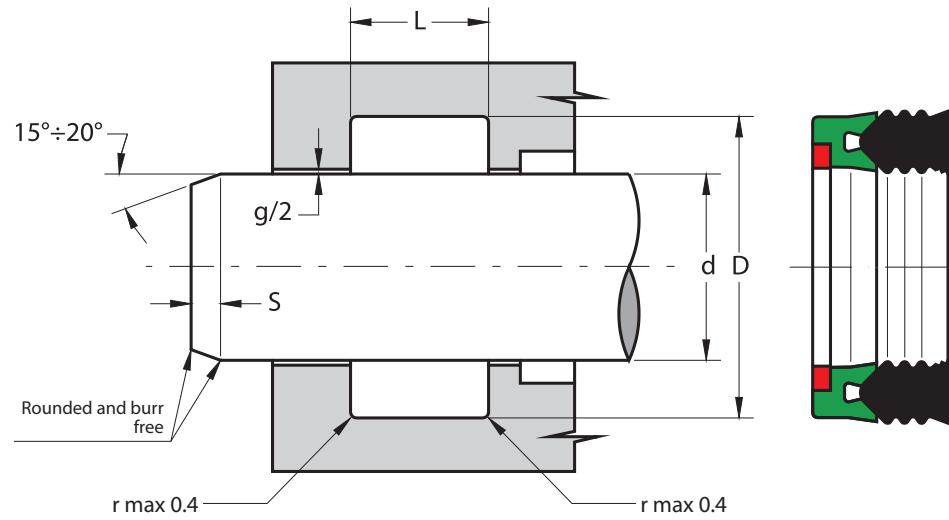

Part.	d <sup>f7</sup>	D <sup>H10</sup>	L <sup>+0.25</sup>	g
<b>SGA 30 43</b>	30	43.0	20.0	0.4
<b>SGA 45 60</b>	45	60.0	22.5	0.4
<b>SGA 60 77</b>	60	77.0	27.0	0.4
<b>SGA 70 90</b>	70	90.0	30.0	0.4
<b>SGA 95 115</b>	95	115.0	28.0	0.4
<b>SGA 110 130</b>	110	130.0	32.5	0.4

# AV

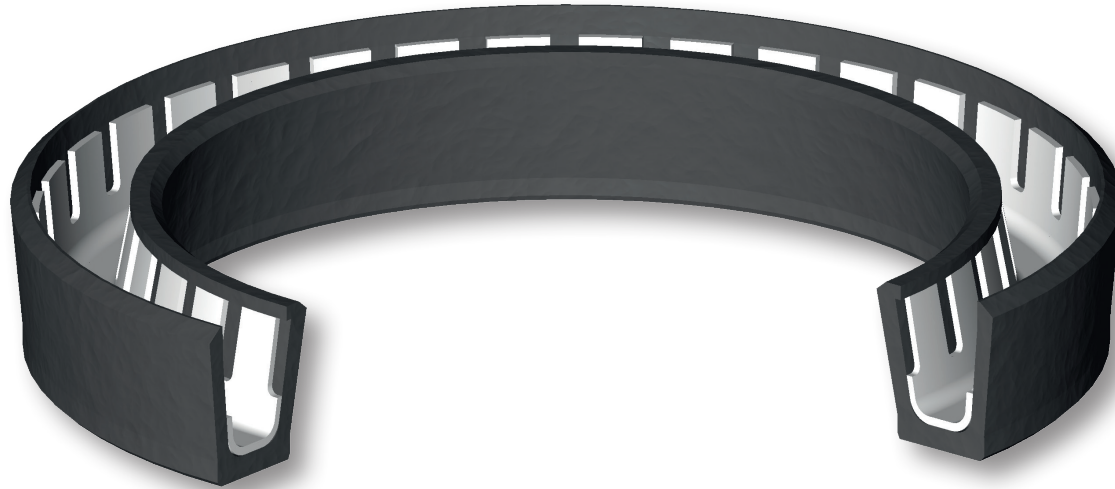

### MATERIAL

- ① **Type Designation** Polytetrafluoroethylene PTFE + carbon  
SEALFLON + Carbon  
⇒ It can be provided with different fillers according to applications
- ② **Type** Stainless 1.4310  
⇒ It can be provided with different materials according to working conditions

### FIELD OF APPLICATION

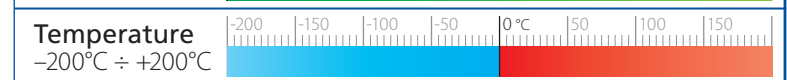
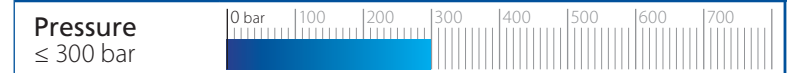

**Fluids** High compatibility with nearly all fluids (which do not attack the PTFE and Stainless)

### SURFACE ROUGHNESS

<b>Dynamic surface</b>	Ra ≤ 0.3 μm	Rt ≤ 2.5 μm
<b>Static surface</b>	Ra ≤ 1.6 μm	Rt ≤ 6.3 μm

### GAP DIMENSION "g"

The largest gap dimension appearing in operation on the non-pressurised side:

L	100 bar	200 bar	300 bar
2.4	0.20	0.16	0.13
3.6	0.30	0.20	0.17
4.8	0.40	0.30	0.22
7.1	0.50	0.40	0.30
9.5	0.60	0.50	0.35

### LEAD-IN CHAMFERS

L	S	L	S
2.4	2.0	7.1	5.0
3.6	2.5	9.5	6.5
4.8	3.5		

To avoid damaging the sealing lips during installation, housing must have rounded chamfers. Sharp edges and burrs within the installation area of the seal must be removed.

The above data are maximum values, they may be maintained for short periods and can not be used at the same time simultaneously.

The Aston Seals AV is a single acting rod seal energized by a V-shaped metal spring resistant to corrosion.

The asymmetric profile, with appropriately designed dynamic lip, short and heavy, ensures a reduction of friction and a long operating life.

The inside metal spring ensures a tight seal even at low pressures.

The possibility of combining different materials for the two components, allows the use of the seal in various areas: hydraulic, chemical, pharmaceutical and food industries.

- High compatibility with nearly all fluids
- Low friction, even in the absence of lubrication

- High speed allowed
- No tendency of stick-slip
- Excellent sealing capability even at low pressure
- Good wear-resistance
- High temperature resistance
- Extended service life

### INSTALLATION

This seal should be mounted preferably in open housing. The snap-in installation is only possible in special designed housing (see figure).

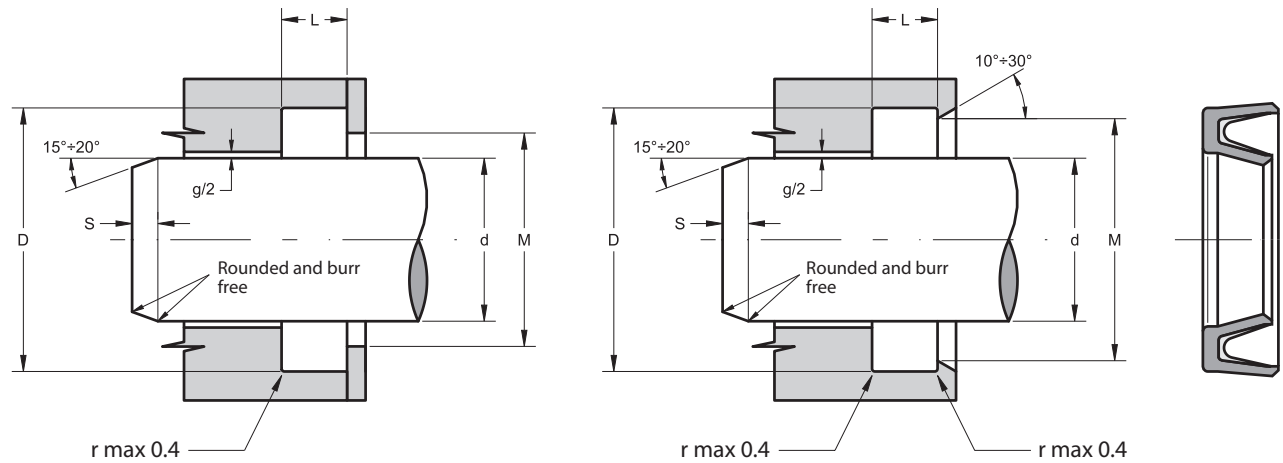

Part.	d <sup>h9</sup>	D <sup>H10</sup>	L <sup>+0.2</sup>	M <sup>max</sup>
AV 5 7.9 2.4	5	7.9	2.4	7.1*
AV 7 9.9 2.4	7	9.9	2.4	9.1*
AV 8 10.9 2.4	8	10.9	2.4	10.1*
AV 10 12.9 2.4	10	12.9	2.4	12.1*
AV 12 16.5 3.6	12	16.5	3.6	15.3
AV 14 18.5 3.6	14	18.5	3.6	17.3
AV 15 19.5 3.6	15	19.5	3.6	18.3
AV 16 20.5 3.6	16	20.5	3.6	19.3
AV 17 21.5 3.6	17	21.5	3.6	20.3
AV 18 22.5 3.6	18	22.5	3.6	21.3
AV 20 24.5 3.6	20	24.5	3.6	23.3
AV 22 28.2 4.8	22	28.2	4.8	26.8
AV 24 30.2 4.8	24	30.2	4.8	28.8
AV 25 31.2 4.8	25	31.2	4.8	29.8
AV 26 32.2 4.8	26	32.2	4.8	30.8
AV 28 34.2 4.8	28	34.2	4.8	32.8
AV 30 36.2 4.8	30	36.2	4.8	34.8
AV 32 38.2 4.8	32	38.2	4.8	36.8
AV 35 41.2 4.8	35	41.2	4.8	39.8
AV 36 42.2 4.8	36	42.2	4.8	40.8
AV 37 43.2 4.8	37	43.2	4.8	41.8
AV 38 44.2 4.8	38	44.2	4.8	42.8

Part.	d <sup>h9</sup>	D <sup>H10</sup>	L <sup>+0.2</sup>	M <sup>max</sup>
AV 40 46.2 4.8	40	46.2	4.8	44.8
AV 42 51.4 7.1	42	51.4	7.1	49.8
AV 45 54.4 7.1	45	54.4	7.1	52.8
AV 48 57.4 7.1	48	57.4	7.1	55.8
AV 50 59.4 7.1	50	59.4	7.1	57.8
AV 52 61.4 7.1	52	61.4	7.1	59.8
AV 55 64.4 7.1	55	64.4	7.1	62.8
AV 58 67.4 7.1	58	67.4	7.1	65.8
AV 60 69.4 7.1	60	69.4	7.1	67.8
AV 65 74.4 7.1	65	74.4	7.1	72.8
AV 70 79.4 7.1	70	79.4	7.1	77.8
AV 75 84.4 7.1	75	84.4	7.1	82.8
AV 80 89.4 7.1	80	89.4	7.1	87.8
AV 85 94.4 7.1	85	94.4	7.1	92.8
AV 90 99.4 7.1	90	99.4	7.1	97.8
AV 95 104.4 7.1	95	104.4	7.1	102.8
AV 100 109.4 7.1	100	109.4	7.1	107.8
AV 110 119.4 7.1	110	119.4	7.1	117.8
AV 120 129.4 7.1	120	129.4	7.1	127.8
AV 125 137.2 9.5	125	137.2	9.5	135.4
AV 130 142.2 9.5	130	142.2	9.5	140.4
AV 140 152.2 9.5	140	152.2	9.5	150.4

Part.	d <sup>h9</sup>	D <sup>H10</sup>	L <sup>+0.2</sup>	M <sup>max</sup>
AV 150 162.2 9.5	150	162.2	9.5	160.4
AV 155 167.2 9.5	155	167.2	9.5	165.4
AV 160 172.2 9.5	160	172.2	9.5	170.4
AV 170 182.2 9.5	170	182.2	9.5	180.4
AV 175 187.2 9.5	175	187.2	9.5	185.4
AV 180 192.2 9.5	180	192.2	9.5	190.4
AV 185 197.2 9.5	185	197.2	9.5	195.4
AV 190 202.2 9.5	190	202.2	9.5	200.4
AV 195 207.2 9.5	195	207.2	9.5	205.4
AV 200 212.2 9.5	200	212.2	9.5	210.4
AV 210 222.2 9.5	210	222.2	9.5	220.4
AV 220 232.2 9.5	220	232.2	9.5	230.4
AV 225 237.2 9.5	225	237.2	9.5	235.4
AV 230 242.2 9.5	230	242.2	9.5	240.4
AV 240 252.2 9.5	240	252.2	9.5	250.4
AV 250 262.2 9.5	250	262.2	9.5	260.4
AV 260 272.2 9.5	260	272.2	9.5	270.4
AV 270 282.2 9.5	270	282.2	9.5	280.4
AV 280 292.2 9.5	280	292.2	9.5	290.4
AV 290 302.2 9.5	290	302.2	9.5	300.4
AV 300 312.2 9.5	300	312.2	9.5	310.4
AV 310 322.2 9.5	310	322.2	9.5	320.4

\* Open groove assembly

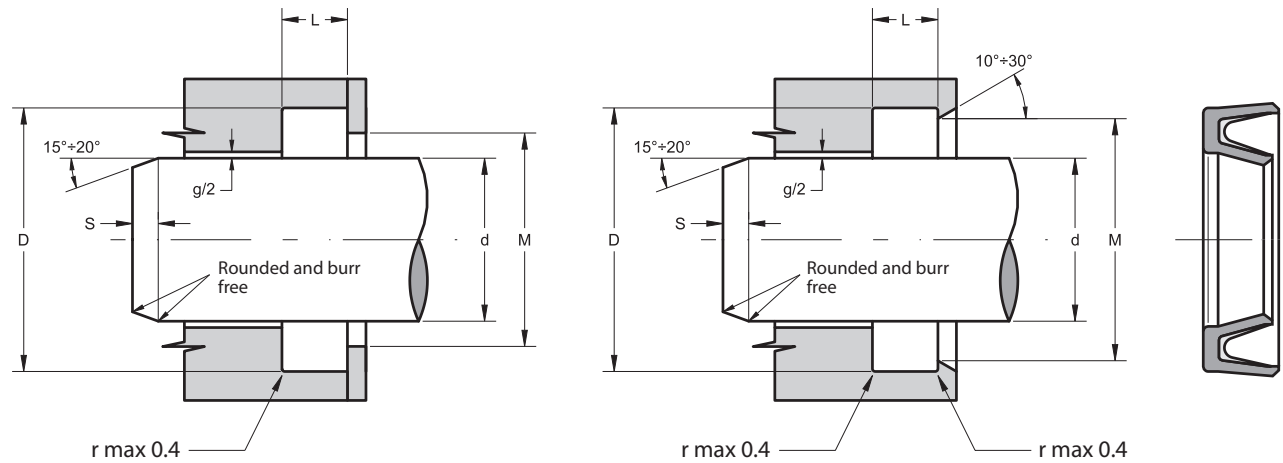

Part.	d <sup>h9</sup>	D <sup>H10</sup>	L <sup>+0.2</sup>	M <sup>max</sup>
AV 320 332.2 9.5	320	332.2	9.5	330.4
AV 330 342.2 9.5	330	342.2	9.5	340.4
AV 340 352.2 9.5	340	352.2	9.5	350.4
AV 350 362.2 9.5	350	362.2	9.5	360.4
AV 360 372.2 9.5	360	372.2	9.5	370.4
AV 370 382.2 9.5	370	382.2	9.5	380.4
AV 380 392.2 9.5	380	392.2	9.5	390.4
AV 390 402.2 9.5	390	402.2	9.5	400.4
AV 400 412.2 9.5	400	412.2	9.5	410.4
AV 420 432.2 9.5	420	432.2	9.5	430.4
AV 440 452.2 9.5	440	452.2	9.5	450.4
AV 450 462.2 9.5	450	462.2	9.5	460.4
AV 460 472.2 9.5	460	472.2	9.5	470.4
AV 480 492.2 9.5	480	492.2	9.5	490.4
AV 500 512.2 9.5	500	512.2	9.5	510.4

Other sizes not present in the above table can be provided in according to the following scheme:

d <sup>h9</sup>	D <sup>H10</sup>	L <sup>+0.2</sup>	M <sup>max</sup>
5-10	d + 2.9	2.4*	d + 2.1
>10-20	d + 4.5	3.6	d + 3.3
>20-40	d + 6.2	4.8	d + 4.8
>40-120	d + 9.4	7.1	d + 7.8
>120-500	d + 12.2	9.5	d + 10.4





# XB



## MATERIAL

- ① **Type** Polytetrafluoroethylene PTFE + Bronze  
**Designation** SEALFLON + Bronze  
 ⇒ It can be provided with different fillers according to applications
- ② **Type** Nitril Rubber NBR  
**Designation** RUBSEAL 70  
**Hardness** 70 °ShA  
 ⇒ It can be provided with different materials according to working conditions

## FIELD OF APPLICATION

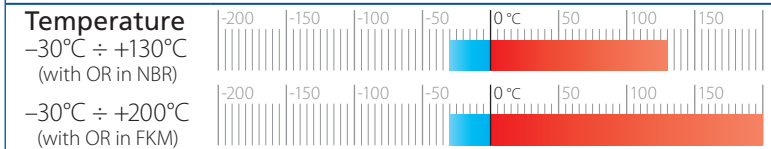

**Fluids** High compatibility with nearly all fluids (with the right choice of O-Ring material)

## SURFACE ROUGHNESS

<b>Dynamic surface</b>	Ra ≤ 0.3 µm	Rt ≤ 2.5 µm
<b>Static surface</b>	Ra ≤ 1.6 µm	Rt ≤ 6.3 µm

## GAP DIMENSION "g"

The largest gap dimension [mm] appearing in operation on the non-pressurised side:

L	100 bar	200 bar	400 bar
2.2	0.60	0.40	0.30
3.2	0.80	0.50	0.30
4.2	0.80	0.50	0.40
6.3	1.00	0.60	0.40
8.1	1.20	0.70	0.50
9.5	1.40	1.00	0.60
13.8	2.00	1.40	1.20

> 400 bar ⇒  $g_{max} = H8/f8$

To avoid damaging the sealing lips during installation, housing must have rounded chamfers. Sharp edges and burrs within the installation area of the seal must be removed.

The above data are maximum values, they may be maintained for short periods and can not be used at the same time simultaneously.

The rod seal type Aston Seals XB is composed of:

- A dynamic seal element which assures exceptional low friction and high speed performance, as well as high compatibility with nearly all media due to the chemical resistance which exceeds that of all other thermoplastics and elastomers
- A standard size O-Ring with low permanent deformation as energizing component on the static side
- Low static and dynamic friction
- High speed allowed
- No tendency of stick-slip
- Space-saving construction and simple

groove design

- High compatibility with nearly all fluids (with the right choice of O-Ring material)
- High resistance against extrusion
- High temperature resistance

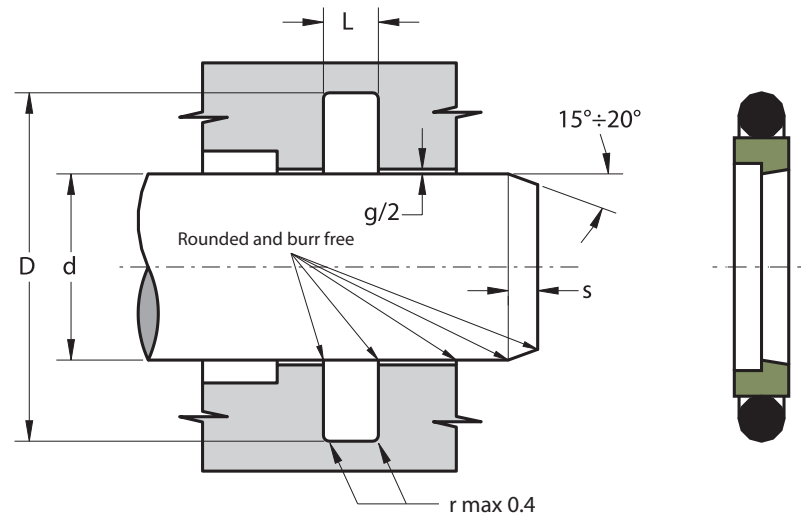

Part.	d <sup>h9</sup>	D <sup>H10</sup>	L <sup>+0.2</sup>	S	OR
<b>XB 4 8.9 2.2</b>	4	8.9	2.2	2.0	009
<b>XB 5 9.9 2.2</b>	5	9.9	2.2	2.0	010
<b>XB 7 11.9 2.2</b>	7	11.9	2.2	2.0	012
<b>XB 8 15.3 3.2</b>	8	15.3	3.2	2.5	111
<b>XB 10 17.3 3.2</b>	10	17.3	3.2	2.5	112
<b>XB 12 19.3 3.2</b>	12	19.3	3.2	2.5	114
<b>XB 14 21.3 3.2</b>	14	21.3	3.2	2.5	115
<b>XB 15 22.3 3.2</b>	15	22.3	3.2	2.5	116
<b>XB 16 23.3 3.2</b>	16	23.3	3.2	2.5	116
<b>XB 17 24.3 3.2</b>	17	24.3	3.2	2.5	117
<b>XB 18 25.3 3.2</b>	18	25.3	3.2	2.5	117
<b>XB 20 30.7 4.2</b>	20	30.7	4.2	3.5	214
<b>XB 22 32.7 4.2</b>	22	32.7	4.2	3.5	215
<b>XB 24 34.7 4.2</b>	24	34.7	4.2	3.5	216
<b>XB 25 35.7 4.2</b>	25	35.7	4.2	3.5	217
<b>XB 26 36.7 4.2</b>	26	36.7	4.2	3.5	218
<b>XB 28 38.7 4.2</b>	28	38.7	4.2	3.5	219
<b>XB 30 40.7 4.2</b>	30	40.7	4.2	3.5	220
<b>XB 32 42.7 4.2</b>	32	42.7	4.2	3.5	221
<b>XB 35 45.7 4.2</b>	35	45.7	4.2	3.5	222
<b>XB 36 46.7 4.2</b>	36	46.7	4.2	3.5	223
<b>XB 37 47.7 4.2</b>	37	47.7	4.2	3.5	223
<b>XB 38 53.1 6.3</b>	38	53.1	6.3	5.0	327
<b>XB 40 55.1 6.3</b>	40	55.1	6.3	5.0	327

Part.	d <sup>h9</sup>	D <sup>H10</sup>	L <sup>+0.2</sup>	S	OR
<b>XB 42 57.1 6.3</b>	42	57.1	6.3	5.0	328
<b>XB 45 60.1 6.3</b>	45	60.1	6.3	5.0	329
<b>XB 48 63.1 6.3</b>	48	63.1	6.3	5.0	330
<b>XB 50 65.1 6.3</b>	50	65.1	6.3	5.0	331
<b>XB 52 67.1 6.3</b>	52	67.1	6.3	5.0	331
<b>XB 55 70.1 6.3</b>	55	70.1	6.3	5.0	332
<b>XB 58 73.1 6.3</b>	58	73.1	6.3	5.0	333
<b>XB 60 75.1 6.3</b>	60	75.1	6.3	5.0	334
<b>XB 65 80.1 6.3</b>	65	80.1	6.3	5.0	335
<b>XB 70 85.1 6.3</b>	70	85.1	6.3	5.0	337
<b>XB 75 90.1 6.3</b>	75	90.1	6.3	5.0	339
<b>XB 80 95.1 6.3</b>	80	95.1	6.3	5.0	340
<b>XB 85 100.1 6.3</b>	85	100.1	6.3	5.0	342
<b>XB 90 105.1 6.3</b>	90	105.1	6.3	5.0	343
<b>XB 95 110.1 6.3</b>	95	110.1	6.3	5.0	345
<b>XB 100 115.1 6.3</b>	100	115.1	6.3	5.0	346
<b>XB 110 125.1 6.3</b>	110	125.1	6.3	5.0	350
<b>XB 120 135.1 6.3</b>	120	135.1	6.3	5.0	353
<b>XB 125 140.1 6.3</b>	125	140.1	6.3	5.0	354
<b>XB 130 145.1 6.3</b>	130	145.1	6.3	5.0	356
<b>XB 140 155.1 6.3</b>	140	155.1	6.3	5.0	359
<b>XB 150 165.1 6.3</b>	150	165.1	6.3	5.0	361
<b>XB 155 170.1 6.3</b>	155	160.1	6.3	5.0	362
<b>XB 160 175.1 6.3</b>	160	175.1	6.3	5.0	363

Part.	d <sup>h9</sup>	D <sup>H10</sup>	L <sup>+0.2</sup>	S	OR
<b>XB 170 185.1 6.3</b>	170	185.1	6.3	5.0	365
<b>XB 175 190.1 6.3</b>	175	190.1	6.3	5.0	366
<b>XB 180 195.1 6.3</b>	180	195.1	6.3	5.0	366
<b>XB 185 200.1 6.3</b>	185	200.1	6.3	5.0	367
<b>XB 190 205.1 6.3</b>	190	205.1	6.3	5.0	368
<b>XB 195 210.1 6.3</b>	195	210.1	6.3	5.0	368
<b>XB 200 220.5 8.1</b>	200	220.5	8.1	6.5	445
<b>XB 210 230.5 8.1</b>	210	230.5	8.1	6.5	446
<b>XB 220 240.5 8.1</b>	220	240.5	8.1	6.5	447
<b>XB 225 245.5 8.1</b>	225	245.5	8.1	6.5	447
<b>XB 230 250.5 8.1</b>	230	250.5	8.1	6.5	678
<b>XB 240 260.5 8.1</b>	240	260.5	8.1	6.5	448
<b>XB 250 270.5 8.1</b>	250	270.5	8.1	6.5	449
<b>XB 260 284.0 8.1</b>	260	284.0	8.1	6.5	450
<b>XB 270 294.0 8.1</b>	270	294.0	8.1	6.5	451
<b>XB 280 304.0 8.1</b>	280	304.0	8.1	6.5	452
<b>XB 290 314.0 8.1</b>	290	314.0	8.1	6.5	453
<b>XB 300 324.0 8.1</b>	300	324.0	8.1	6.5	454
<b>XB 310 334.0 8.1</b>	310	334.0	8.1	6.5	454
<b>XB 320 344.0 8.1</b>	320	344.0	8.1	6.5	455
<b>XB 330 354.0 8.1</b>	330	354.0	8.1	6.5	456
<b>XB 340 364.0 8.1</b>	340	364.0	8.1	6.5	457
<b>XB 350 374.0 8.1</b>	350	374.0	8.1	6.5	458
<b>XB 360 384.0 8.1</b>	360	384.0	8.1	6.5	458

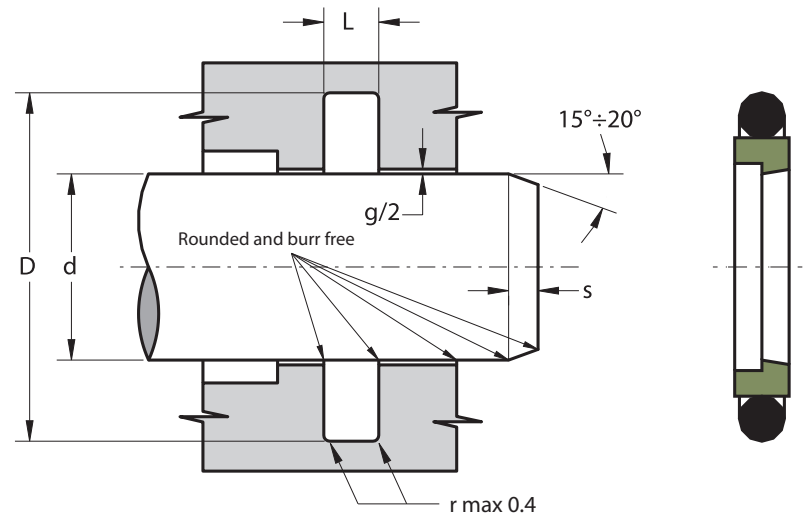

Part.	d <sup>h9</sup>	D <sup>H10</sup>	L <sup>+0.2</sup>	S	OR
<b>XB 370 394.0 8.1</b>	370	394.0	8.1	6.5	459
<b>XB 380 404.0 8.1</b>	380	404.0	8.1	6.5	460
<b>XB 390 414.0 8.1</b>	390	414.0	8.1	6.5	461
<b>XB 400 424.0 8.1</b>	400	424.0	8.1	6.5	461
<b>XB 420 444.0 8.1</b>	420	444.0	8.1	6.5	463
<b>XB 440 464.0 8.1</b>	440	464.0	8.1	6.5	464
<b>XB 450 474.0 8.1</b>	450	474.0	8.1	6.5	465
<b>XB 460 484.0 8.1</b>	460	484.0	8.1	6.5	466
<b>XB 480 504.0 8.1</b>	480	504.0	8.1	6.5	468
<b>XB 500 524.0 8.1</b>	500	524.0	8.1	6.5	469

Other sizes not present in the above table can be provided in according to the following scheme:

d			D	L	S	S. OR
Light series	Standard series	Heavy series				
8 ÷ 18.9	<b>3 ÷ 7.9</b>		d + 4.90	2.2	2.0	1.78
19 ÷ 37.9	<b>8 ÷ 18.9</b>		d + 7.30	3.2	2.5	2.62
38 ÷ 199.9	<b>19 ÷ 37.9</b>	8 ÷ 18.9	d + 10.7	4.2	3.5	3.53
200 ÷ 255.9	<b>38 ÷ 199.9</b>	19 ÷ 37.9	d + 15.1	6.3	5.0	5.34
256 ÷ 649.9	<b>200 ÷ 255.9</b>	38 ÷ 199.9	d + 20.5	8.1	6.5	6.99
650 ÷ 999.9	<b>256 ÷ 649.9</b>	200 ÷ 255.9	d + 24.0	8.1	6.5	6.99
	<b>650 ÷ 999.9</b>	256 ÷ 649.9	d + 27.3	9.5	7.5	8.40
	<b>&gt; 1000</b>		d + 38.0	13.8	10.0	12.0



# XAB

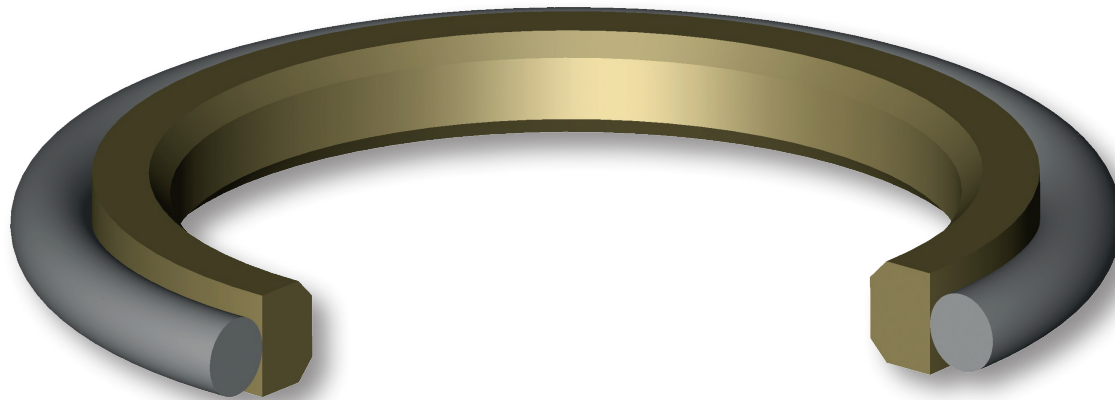

XAB

The rod seal type Aston Seals XAB is composed of:

- A dynamic seal element which assures exceptional low friction and high speed performance, as well as high compatibility with nearly all media due to the chemical resistance which exceeds that of all other thermoplastics and elastomers.
- A standard size O-Ring with low permanent deformation as energizing component on the static side
- Low static and dynamic friction
- High speed allowed
- No tendency of stick-slip
- Space-saving construction and simple

groove design

- High compatibility with nearly all fluids (with the right choice of O-Ring material)
- High resistance against extrusion
- High temperature resistance

## MATERIAL

- ① **Type** Polytetrafluoroethylene PTFE + Bronze  
**Designation** SEALFLON + Bronze  
 ⇒ It can be provided with different fillers according to applications
- ② **Type** Nitril Rubber NBR  
**Designation** RUBSEAL 70  
**Hardness** 70 °ShA  
 ⇒ It can be provided with different materials according to working conditions

## FIELD OF APPLICATION

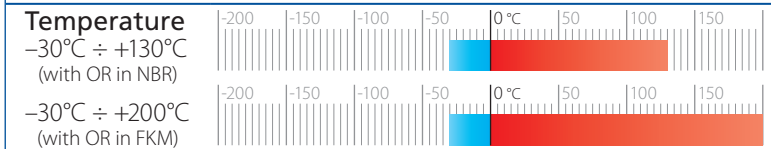
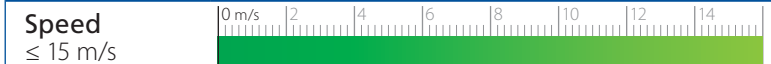

**Fluids** High compatibility with nearly all fluids (with the right choice of O-Ring material)

## SURFACE ROUGHNESS

<b>Dynamic surface</b>	Ra ≤ 0.3 µm	Rt ≤ 2.5 µm
<b>Static surface</b>	Ra ≤ 1.6 µm	Rt ≤ 6.3 µm

## GAP DIMENSION "g"

The largest gap dimension [mm] appearing in operation on the non-pressurised side:

L	100 bar	200 bar	400 bar
2.2	0.60	0.40	0.30
3.2	0.80	0.50	0.30
4.2	0.80	0.50	0.40
6.3	1.00	0.60	0.40
8.1	1.20	0.70	0.50
9.5	1.40	1.00	0.60
13.8	2.00	1.40	1.20

> 400 bar ⇒  $g_{max} = H8/f8$

To avoid damaging the sealing lips during installation, housing must have rounded chamfers. Sharp edges and burrs within the installation area of the seal must be removed.

The above data are maximum values, they may be maintained for short periods and can not be used at the same time simultaneously.

# XAB

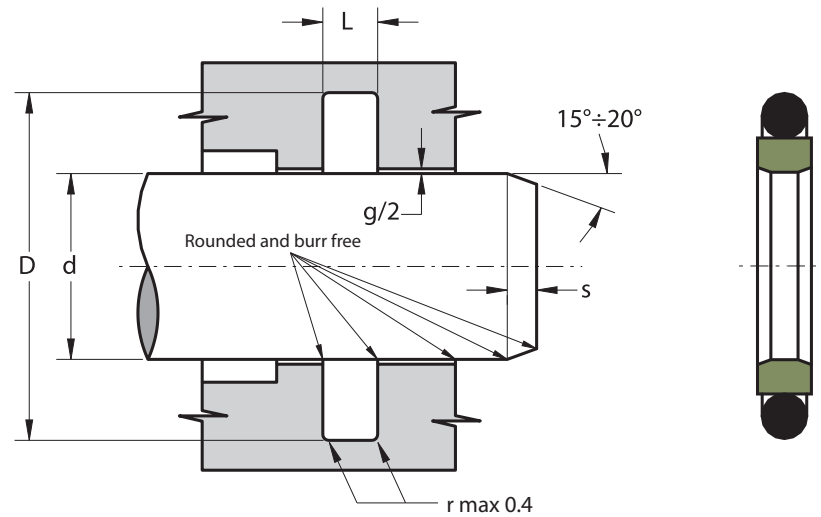

Part.	d <sup>h9</sup>	D <sup>H10</sup>	L <sup>+0.2</sup>	S	OR
XAB 4 8.9 2.2	4	8.9	2.2	2.0	009
XAB 5 9.9 2.2	5	9.9	2.2	2.0	010
XAB 7 11.9 2.2	7	11.9	2.2	2.0	012
XAB 8 15.3 3.2	8	15.3	3.2	2.5	111
XAB 10 17.3 3.2	10	17.3	3.2	2.5	112
XAB 12 19.3 3.2	12	19.3	3.2	2.5	114
XAB 14 21.3 3.2	14	21.3	3.2	2.5	115
XAB 15 22.3 3.2	15	22.3	3.2	2.5	116
XAB 16 23.3 3.2	16	23.3	3.2	2.5	116
XAB 17 24.3 3.2	17	24.3	3.2	2.5	117
XAB 18 25.3 3.2	18	25.3	3.2	2.5	117
XAB 20 30.7 4.2	20	30.7	4.2	3.5	214
XAB 22 32.7 4.2	22	32.7	4.2	3.5	215
XAB 24 34.7 4.2	24	34.7	4.2	3.5	216
XAB 25 35.7 4.2	25	35.7	4.2	3.5	217
XAB 26 36.7 4.2	26	36.7	4.2	3.5	218
XAB 28 38.7 4.2	28	38.7	4.2	3.5	219
XAB 30 40.7 4.2	30	40.7	4.2	3.5	220
XAB 32 42.7 4.2	32	42.7	4.2	3.5	221
XAB 35 45.7 4.2	35	45.7	4.2	3.5	222
XAB 36 46.7 4.2	36	46.7	4.2	3.5	223
XAB 37 47.7 4.2	37	47.7	4.2	3.5	223
XAB 38 53.1 6.3	38	53.1	6.3	5.0	327
XAB 40 55.1 6.3	40	55.1	6.3	5.0	327

Part.	d <sup>h9</sup>	D <sup>H10</sup>	L <sup>+0.2</sup>	S	OR
XAB 42 57.1 6.3	42	57.1	6.3	5.0	328
XAB 45 60.1 6.3	45	60.1	6.3	5.0	329
XAB 48 63.1 6.3	48	63.1	6.3	5.0	330
XAB 50 65.1 6.3	50	65.1	6.3	5.0	331
XAB 52 67.1 6.3	52	67.1	6.3	5.0	331
XAB 55 70.1 6.3	55	70.1	6.3	5.0	332
XAB 58 73.1 6.3	58	73.1	6.3	5.0	333
XAB 60 75.1 6.3	60	75.1	6.3	5.0	334
XAB 65 80.1 6.3	65	80.1	6.3	5.0	335
XAB 70 85.1 6.3	70	85.1	6.3	5.0	337
XAB 75 90.1 6.3	75	90.1	6.3	5.0	339
XAB 80 95.1 6.3	80	95.1	6.3	5.0	340
XAB 85 100.1 6.3	85	100.1	6.3	5.0	342
XAB 90 105.1 6.3	90	105.1	6.3	5.0	343
XAB 95 110.1 6.3	95	110.1	6.3	5.0	345
XAB 100 115.1 6.3	100	115.1	6.3	5.0	346
XAB 110 125.1 6.3	110	125.1	6.3	5.0	350
XAB 120 135.1 6.3	120	135.1	6.3	5.0	353
XAB 125 140.1 6.3	125	140.1	6.3	5.0	354
XAB 130 145.1 6.3	130	145.1	6.3	5.0	356
XAB 140 155.1 6.3	140	155.1	6.3	5.0	359
XAB 150 165.1 6.3	150	165.1	6.3	5.0	361
XAB 155 170.1 6.3	155	170.1	6.3	5.0	362
XAB 160 175.1 6.3	160	175.1	6.3	5.0	363

Part.	d <sup>h9</sup>	D <sup>H10</sup>	L <sup>+0.2</sup>	S	OR
XAB 170 185.1 6.3	170	185.1	6.3	5.0	365
XAB 175 190.1 6.3	175	190.1	6.3	5.0	366
XAB 180 195.1 6.3	180	195.1	6.3	5.0	366
XAB 185 200.1 6.3	185	200.1	6.3	5.0	367
XAB 190 205.1 6.3	190	205.1	6.3	5.0	368
XAB 195 210.1 6.3	195	210.1	6.3	5.0	368
XAB 200 220.5 8.1	200	220.5	8.1	6.5	674
XAB 210 230.5 8.1	210	230.5	8.1	6.5	446
XAB 220 240.5 8.1	220	240.5	8.1	6.5	447
XAB 225 245.5 8.1	225	245.5	8.1	6.5	447
XAB 230 250.5 8.1	230	250.5	8.1	6.5	678
XAB 240 260.5 8.1	240	260.5	8.1	6.5	448
XAB 250 270.5 8.1	250	270.5	8.1	6.5	449
XAB 260 284.0 8.1	260	284.0	8.1	6.5	450
XAB 270 294.0 8.1	270	294.0	8.1	6.5	451
XAB 280 304.0 8.1	280	304.0	8.1	6.5	452
XAB 290 314.0 8.1	290	314.0	8.1	6.5	453
XAB 300 324.0 8.1	300	324.0	8.1	6.5	454
XAB 310 334.0 8.1	310	334.0	8.1	6.5	454
XAB 320 344.0 8.1	320	344.0	8.1	6.5	455
XAB 330 354.0 8.1	330	354.0	8.1	6.5	456
XAB 340 364.0 8.1	340	364.0	8.1	6.5	457
XAB 350 374.0 8.1	350	374.0	8.1	6.5	458
XAB 360 384.0 8.1	360	384.0	8.1	6.5	458

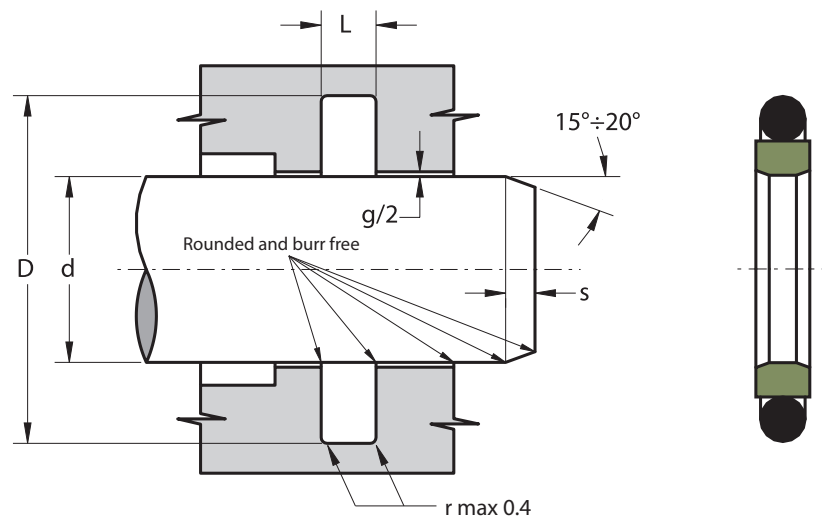

Part.	d <sup>h9</sup>	D <sup>H10</sup>	L <sup>+0.2</sup>	S	OR
<b>XAB 370 394.0 8.1</b>	370	394.0	8.1	6.5	459
<b>XAB 380 404.0 8.1</b>	380	404.0	8.1	6.5	460
<b>XAB 390 414.0 8.1</b>	390	414.0	8.1	6.5	461
<b>XAB 400 424.0 8.1</b>	400	424.0	8.1	6.5	461
<b>XAB 420 444.0 8.1</b>	420	444.0	8.1	6.5	463
<b>XAB 440 464.0 8.1</b>	440	464.0	8.1	6.5	464
<b>XAB 450 474.0 8.1</b>	450	474.0	8.1	6.5	465
<b>XAB 460 484.0 8.1</b>	460	484.0	8.1	6.5	466
<b>XAB 480 504.0 8.1</b>	480	504.0	8.1	6.5	468
<b>XAB 500 524.0 8.1</b>	500	524.0	8.1	6.5	469

Other sizes not present in the above table can be provided in according to the following scheme:

d			D	L	S	S. OR
Light series	Standard series	Heavy series				
8 ÷ 18.9	<b>3 ÷ 7.9</b>		d + 4.90	2.2	2.0	1.78
19 ÷ 37.9	<b>8 ÷ 18.9</b>		d + 7.30	3.2	2.5	2.62
38 ÷ 199.9	<b>19 ÷ 37.9</b>	8 ÷ 18.9	d + 10.7	4.2	3.5	3.53
200 ÷ 255.9	<b>38 ÷ 199.9</b>	19 ÷ 37.9	d + 15.1	6.3	5.0	5.34
256 ÷ 649.9	<b>200 ÷ 255.9</b>	38 ÷ 199.9	d + 20.5	8.1	6.5	6.99
650 ÷ 999.9	<b>256 ÷ 649.9</b>	200 ÷ 255.9	d + 24.0	8.1	6.5	6.99
	<b>650 ÷ 999.9</b>	256 ÷ 649.9	d + 27.3	9.5	7.5	8.40
	<b>&gt; 1000</b>		d + 38.0	13.8	10.0	12.0





# XRB



XRB

The rod seal type Aston Seals XRB, used preferably for hydraulic joints and rotary joints, is composed of:

- A dynamic seal element which assures exceptional low friction and high speed performance, as well as high compatibility with nearly all media due to the chemical resistance which exceeds that of all other thermoplastics and elastomers
- A standard size O-Ring with low permanent deformation as energizing component on the static side
- Low static and dynamic friction
- High speed allowed
- No tendency of stick-slip

- Can also work for single action
- Space-saving construction and simple groove design
- High compatibility with nearly all fluids (with the right choice of O-Ring material)
- High resistance against extrusion
- High temperature resistance

## MATERIAL

- ① **Type Designation** Polytetrafluoroethylene PTFE + Bronze  
SEALFLON + Bronze  
⇒ It can be provided with different fillers according to applications
- ② **Type Designation** Nitril Rubber NBR  
RUBSEAL 70  
**Hardness** 70 °ShA  
⇒ It can be provided with different materials according to working conditions

## FIELD OF APPLICATION

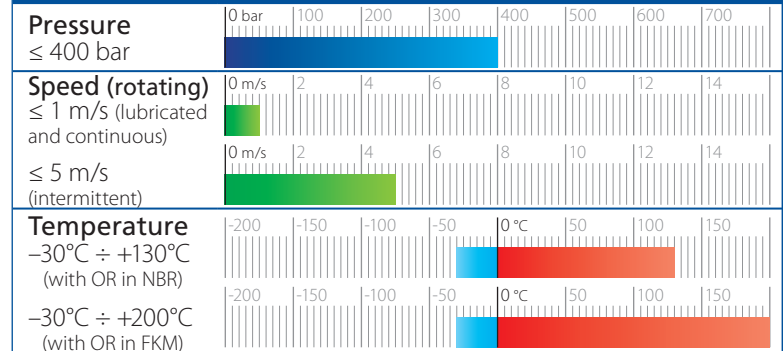

**Fluids** High compatibility with nearly all fluids (with the right choice of O-Ring material)

## SURFACE ROUGHNESS

<b>Dynamic surface</b>	Ra ≤ 0.3 µm	Rt ≤ 2.5 µm
<b>Static surface</b>	Ra ≤ 1.6 µm	Rt ≤ 6.3 µm

## GAP DIMENSION "g"

The largest gap dimension [mm] appearing in operation on the non-pressurised side:

L	100 bar	200 bar	300 bar
2.2	0.30	0.20	0.10
3.2	0.50	0.30	0.20
4.2	0.50	0.30	0.20
6.3	0.60	0.40	0.30
8.1	0.60	0.40	0.30
9.5	0.90	0.60	0.50

> 400 bar ⇒  $g_{max} = H8/f8$

To avoid damaging the sealing lips during installation, housing must have rounded chamfers. Sharp edges and burrs within the installation area of the seal must be removed.

The above data are maximum values, they may be maintained for short periods and can not be used at the same time simultaneously.

# XRB

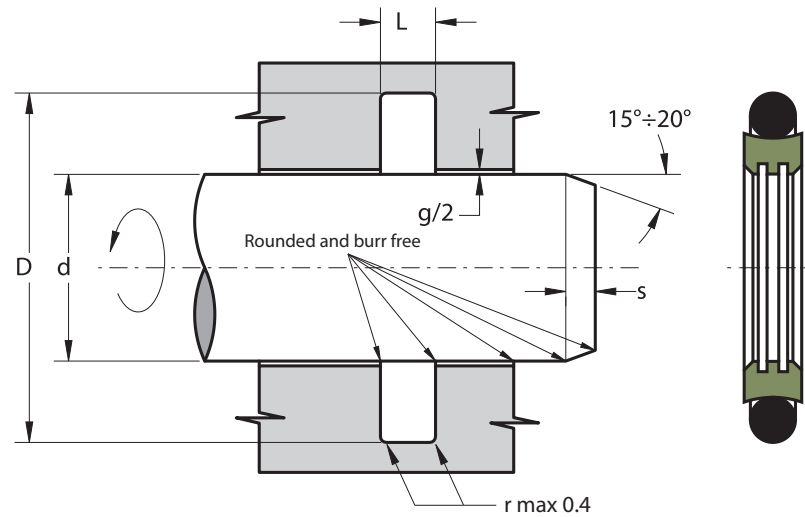

Part.	d <sup>f8</sup>	D <sup>H9</sup>	L <sup>+0.2</sup>	S	OR
<b>XRB 6 10.9 2.2</b>	6	10.9	2.2	2.0	011
<b>XRB 8 12.9 2.2</b>	8	12.9	2.2	2.0	012
<b>XRB 10 14.9 2.2</b>	10	14.9	2.2	2.0	013
<b>XRB 12 16.9 2.2</b>	12	16.9	2.2	2.0	015
<b>XRB 14 18.9 2.2</b>	14	18.9	2.2	2.0	016
<b>XRB 15 19.9 2.2</b>	15	19.9	2.2	2.0	017
<b>XRB 16 20.9 2.2</b>	16	20.9	2.2	2.0	017
<b>XRB 18 22.9 2.2</b>	18	22.9	2.2	2.0	019
<b>XRB 20 27.5 3.2</b>	20	27.5	3.2	2.5	119
<b>XRB 22 29.5 3.2</b>	22	29.5	3.2	2.5	120
<b>XRB 25 32.5 3.2</b>	25	32.5	3.2	2.5	122
<b>XRB 28 35.5 3.2</b>	28	35.5	3.2	2.5	124
<b>XRB 30 37.5 3.2</b>	30	37.5	3.2	2.5	125
<b>XRB 32 39.5 3.2</b>	32	39.5	3.2	2.5	126
<b>XRB 35 42.5 3.2</b>	35	42.5	3.2	2.5	128
<b>XRB 36 43.5 3.2</b>	36	43.5	3.2	2.5	129
<b>XRB 40 51 4.2</b>	40	51	4.2	3.5	224
<b>XRB 42 53 4.2</b>	42	53	4.2	3.5	828
<b>XRB 45 56 4.2</b>	45	56	4.2	3.5	830
<b>XRB 48 59 4.2</b>	48	59	4.2	3.5	832
<b>XRB 50 61 4.2</b>	50	61	4.2	3.5	833
<b>XRB 52 63 4.2</b>	52	63	4.2	3.5	228
<b>XRB 55 66 4.2</b>	55	66	4.2	3.5	836

Part.	d <sup>f8</sup>	D <sup>H9</sup>	L <sup>+0.2</sup>	S	OR
<b>XRB 56 67 4.2</b>	56	67	4.2	3.5	229
<b>XRB 60 71 4.2</b>	60	71	4.2	3.5	839
<b>XRB 63 74 4.2</b>	63	74	4.2	3.5	841
<b>XRB 65 76 4.2</b>	65	76	4.2	3.5	232
<b>XRB 70 81 4.2</b>	70	81	4.2	3.5	846
<b>XRB 75 86 4.2</b>	75	86	4.2	3.5	235
<b>XRB 80 91 4.2</b>	80	91	4.2	3.5	236
<b>XRB 85 96 4.2</b>	85	96	4.2	3.5	238
<b>XRB 90 101 4.2</b>	90	101	4.2	3.5	240
<b>XRB 95 106 4.2</b>	95	106	4.2	3.5	241
<b>XRB 100 111 4.2</b>	100	111	4.2	3.5	242
<b>XRB 105 116 4.2</b>	105	116	4.2	3.5	244
<b>XRB 110 121 4.2</b>	110	121	4.2	3.5	246
<b>XRB 115 126 4.2</b>	115	126	4.2	3.5	247
<b>XRB 120 131 4.2</b>	120	131	4.2	3.5	249
<b>XRB 125 136 4.2</b>	125	136	4.2	3.5	251
<b>XRB 130 141 4.2</b>	130	141	4.2	3.5	252
<b>XRB 135 146 4.2</b>	135	146	4.2	3.5	254
<b>XRB 140 151 4.2</b>	140	151	4.2	3.5	255
<b>XRB 145 156 4.2</b>	145	156	4.2	3.5	257
<b>XRB 150 161 4.2</b>	150	161	4.2	3.5	258
<b>XRB 160 171 4.2</b>	160	171	4.2	3.5	259
<b>XRB 170 181 4.2</b>	170	181	4.2	3.5	261

Part.	d <sup>f8</sup>	D <sup>H9</sup>	L <sup>+0.2</sup>	S	OR
<b>XRB 180 191 4.2</b>	180	191	4.2	3.5	263
<b>XRB 190 201 4.2</b>	190	201	4.2	3.5	264
<b>XRB 200 215.5 6.3</b>	200	215.5	6.3	5.0	369
<b>XRB 210 225.5 6.3</b>	210	225.5	6.3	5.0	371
<b>XRB 220 235.5 6.3</b>	220	235.5	6.3	5.0	373
<b>XRB 240 255.5 6.3</b>	240	255.5	6.3	5.0	376
<b>XRB 250 265.5 6.3</b>	250	265.5	6.3	5.0	377
<b>XRB 280 301 8.1</b>	280	301	8.1	6.5	452
<b>XRB 300 321 8.1</b>	300	321	8.1	6.5	453
<b>XRB 320 341 8.1</b>	320	341	8.1	6.5	455
<b>XRB 350 371 8.1</b>	350	371	8.1	6.5	457
<b>XRB 360 381 8.1</b>	360	381	8.1	6.5	458
<b>XRB 400 421 8.1</b>	400	421	8.1	6.5	461
<b>XRB 420 441 8.1</b>	420	441	8.1	6.5	462
<b>XRB 450 471 8.1</b>	450	471	8.1	6.5	465
<b>XRB 480 501 8.1</b>	480	501	8.1	6.5	467
<b>XRB 500 521 8.1</b>	500	521	8.1	6.5	469
<b>XRB 520 541 8.1</b>	520	541	8.1	6.5	470
<b>XRB 550 571 8.1</b>	550	571	8.1	6.5	471
<b>XRB 600 621 8.1</b>	600	621	8.1	6.5	473
<b>XRB 650 678 9.5</b>	650	678	9.5	7.5	660x8.4
<b>XRB 700 728 9.5</b>	700	728	9.5	7.5	710x8.4
<b>XRB 750 778 9.5</b>	750	778	9.5	7.5	760x8.4

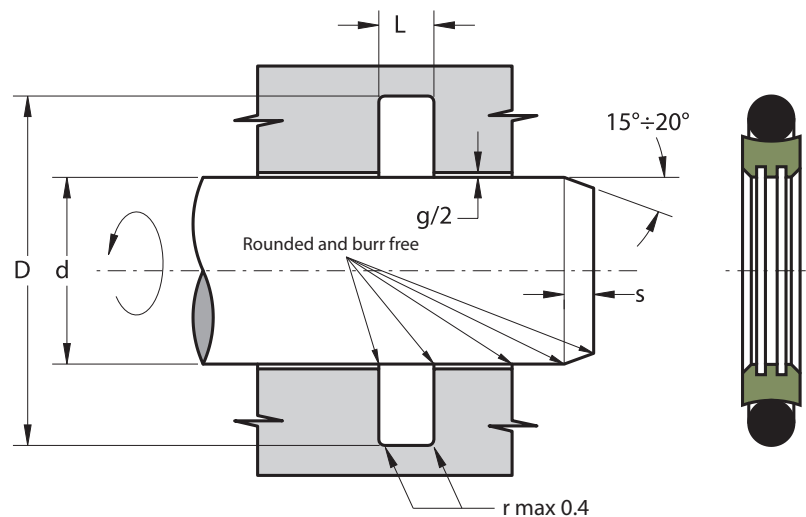

Other sizes not present in the above table can be provided in according to the following scheme:

d	D	L	S	S. OR
6 ÷ 18.9	d + 4.9	2.20	2.0	1.78
19 ÷ 37.9	d + 7.5	3.20	2.5	2.62
38 ÷ 199.9	d + 11.0	4.20	3.5	3.53
200 ÷ 255.9	d + 15.5	6.30	5.0	5.34
256 ÷ 649.9	d + 21.0	8.10	6.5	6.99
650 ÷ 999.9	d + 28.0	9.50	7.5	8.40



# XL

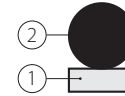

① **Type** Polytetrafluoroethylene PTFE + Carbon  
**Designation** SEALFLON + Carbon

⇒ It can be provided with different fillers according to applications

② **Type** Nitril Rubber NBR  
**Designation** RUBSEAL 70  
**Hardness** 70 °ShA

⇒ It can be provided with different materials according to working conditions

## FIELD OF APPLICATION

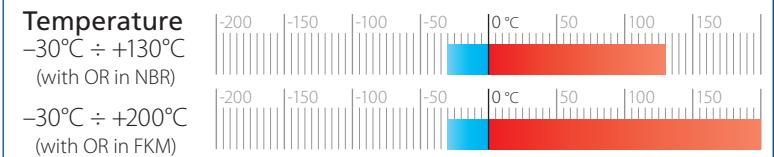

**Fluids** High compatibility with nearly all fluids  
 (with the right choice of O-Ring material)

## SURFACE ROUGHNESS

<b>Dynamic surface</b>	Ra ≤ 0.3 µm	Rt ≤ 2.5 µm
<b>Static surface</b>	Ra ≤ 1.6 µm	Rt ≤ 6.3 µm

## GAP DIMENSION "g"

The largest gap dimension appearing in operation on the non-pressurised side must comply with the ISO H8/f7:

To avoid damaging the sealing lips during installation, housing must have rounded chamfers. Sharp edges and burrs within the installation area of the seal must be removed.

The above data are maximum values, they may be maintained for short periods and can not be used at the same time simultaneously.

The rod seal type Aston Seals XL, mainly suitable for low pressure conditions or pneumatic field, is composed of:

- A dynamic seal element which assures exceptional low friction and high speed performance, as well as high compatibility with nearly all media due to the chemical resistance which exceeds that of all other thermoplastics and elastomers.
- A standard size O-Ring with low permanent deformation as energizing component on the static side
- Low static and dynamic friction, also without lubrication
- No tendency of stick-slip

- Space-saving construction and simple groove design
- Good resistance against extrusion
- High compatibility with nearly all fluids (with the right choice of O-Ring material)
- High speed allowed
- High temperature resistance

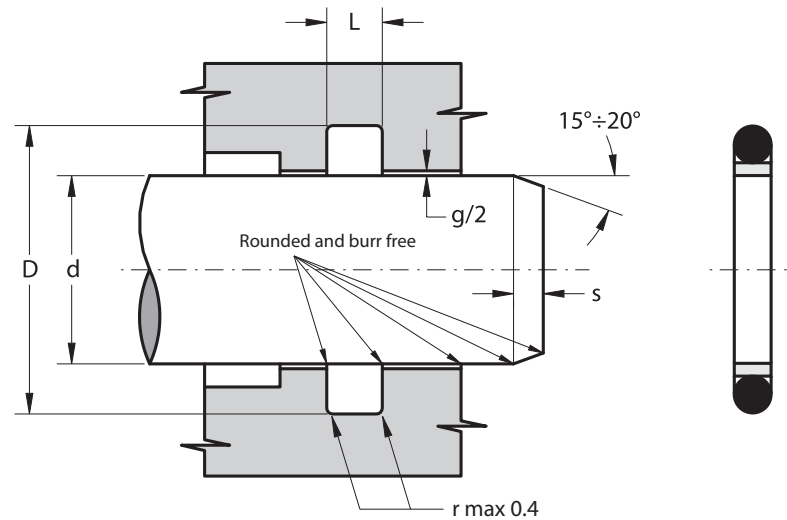

Part.	d <sup>f7</sup>	D <sup>H9</sup>	L <sup>+0.2</sup>	S	OR
XL 610-5	5	9.5	2	3.0	610
XL 011-6	6	10.5	2	3.0	011
XL 012-8	8	12.5	2	3.0	012
XL 614-10	10	16.2	3	3.5	614
XL 113-12	12	18.2	3	3.5	113
XL 114-14	14	20.2	3	3.5	114
XL 809-15	15	21.1	3	3.5	809
XL 617-16	16	22.2	3	3.5	617
XL 116-18	18	24.1	3	3.5	116
XL 118-20	20	26.2	3	3.5	118
XL 119-22	22	28.2	3	3.5	119
XL 121-25	25	31.2	3	3.5	121
XL 217-28	28	36.0	4	4.5	217
XL 218-30	30	38.0	4	4.5	218
XL 219-32	32	39.9	4	4.5	219
XL 221-35	35	42.9	4	4.5	221

Part.	d <sup>f7</sup>	D <sup>H9</sup>	L <sup>+0.2</sup>	S	OR
XL 824-38	38	46.0	4	4.5	824
XL 825-40	40	48.0	4	4.5	825
XL 224-42	42	50.0	4	4.5	224
XL 225-45	45	53.0	4	4.5	225
XL 329-50	50	61.6	6	6.0	329
XL 331-55	55	66.7	6	6.0	331
XL 331-56	56	67.6	6	6.0	331
XL 333-60	60	71.7	6	6.0	333
XL 334-63	63	74.7	6	6.0	334
XL 334-65	65	76.6	6	6.0	334
XL 336-70	70	81.7	6	6.0	336
XL 338-75	75	87.1	6	6.0	338
XL 339-80	80	92.1	6	6.0	339
XL 341-85	85	97.1	6	6.0	341
XL 342-90	90	102.1	6	6.0	342
XL 344-95	95	107.1	6	6.0	344

Part.	d <sup>f7</sup>	D <sup>H9</sup>	L <sup>+0.2</sup>	S	OR
XL 345-100	100	112.1	6	6.0	345
XL 348-110	110	122.0	6	6.0	348
XL 428-120	120	135.5	8	8.0	428
XL 429-125	125	140.5	8	8.0	429
XL 431-130	130	145.5	8	8.0	431
XL 434-140	140	155.5	8	8.0	434
XL 437-150	150	165.5	8	8.0	437
XL 439-160	160	175.5	8	8.0	439
XL 878-170	170	186.3	8	8.0	878
XL 442-180	180	196.3	8	8.0	442
XL 884-190	190	206.3	8	8.0	884
XL 445-200	200	216.3	8	8.0	445
XL 449-250	250	266.3	8	8.0	449
XL 686-280	280	296.3	8	8.0	686
XL 453-300	300	316.3	8	8.0	453

Other sizes not present in the above table can be provided on request

# XC



## MATERIAL

	① <b>Type</b>	Polytetrafluoroethylene PTFE
	<b>Designation</b>	SEALFLON
⇒ It can be provided with different fillers according to applications		
	② <b>Type</b>	Nitril Rubber NBR
	<b>Designation</b>	RUBSEAL 70
	<b>Hardness</b>	70 °ShA
⇒ It can be provided with different materials according to working conditions		

## FIELD OF APPLICATION

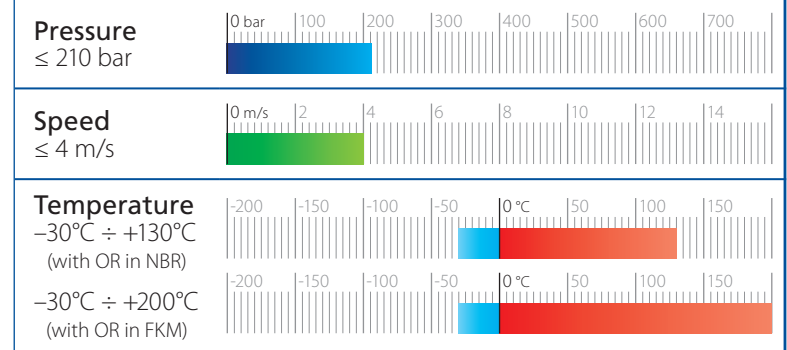

**Fluids** High compatibility with nearly all fluids (with the right choice of O-Ring material)

## SURFACE ROUGHNESS

<b>Dynamic surface</b>	Ra ≤ 0.3 µm	Rt ≤ 2.5 µm
<b>Static surface</b>	Ra ≤ 1.6 µm	Rt ≤ 6.3 µm

## GAP DIMENSION "g"

The largest gap dimension appearing in operation on the non-pressurised side must comply with the ISO H8/f7:

To avoid damaging the sealing lips during installation, housing must have rounded chamfers. Sharp edges and burrs within the installation area of the seal must be removed.

The above data are maximum values, they may be maintained for short periods and can not be used at the same time simultaneously.

The rod seal type Aston Seals XC, mainly suitable for low pressure conditions or pneumatic field, is composed of:

- A dynamic seal element which assures exceptional low friction and high speed performance, as well as high compatibility with nearly all media due to the chemical resistance which exceeds that of all other thermoplastics and elastomers.
- A standard size O-Ring with low permanent deformation as energizing component on the static side
- Low static and dynamic friction, also without lubrication
- No tendency of stick-slip

- Space-saving construction and simple groove design
- Good resistance against extrusion
- High compatibility with nearly all fluids (with the right choice of O-Ring material)
- High speed allowed
- High temperature resistance



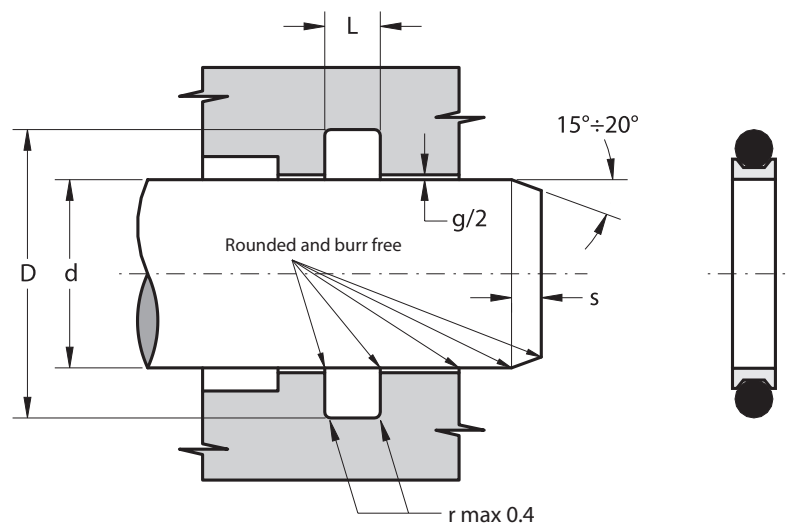

Part.	d <sup>f7</sup>	D <sup>H9</sup>	L <sup>+0.2</sup>	S	OR
XC 007-3	3	6.5	2.5	2.0	007
XC 008-4	4	7.5	2.5	2.0	008
XC 009-5	5	8.5	2.5	2.0	009
XC 010-6	6	9.5	2.5	2.0	010
XC 011-8	8	11.5	2.5	2.0	011
XC 012-10	10	13.5	2.5	2.0	012
XC 110-9	9	14.5	3.5	2.5	110
XC 111-11	11	16.5	3.5	2.5	111
XC 112-12	12	17.5	3.5	2.5	112
XC 113-14	14	19.5	3.5	2.5	113
XC 114-15	15	20.5	3.5	2.5	114
XC 115-17	17	22.5	3.5	2.5	115
XC 210-19	19	26.1	4.5	3.0	210
XC 211-20	20	27.1	4.5	3.0	211
XC 212-22	22	29.1	4.5	3.0	212
XC 213-23	23	30.1	4.5	3.0	213
XC 214-25	25	32.1	4.5	3.0	214
XC 215-27	27	34.1	4.5	3.0	215
XC 216-28	28	35.1	4.5	3.0	216
XC 217-30	30	37.1	4.5	3.0	217
XC 218-31	31	38.1	4.5	3.0	218
XC 219-33	33	40.1	4.5	3.0	219

Part.	d <sup>f7</sup>	D <sup>H9</sup>	L <sup>+0.2</sup>	S	OR
XC 220-35	35	42.1	4.5	3.0	220
XC 221-36	36	43.1	4.5	3.0	221
XC 325-38	38	48.4	7.0	4.0	325
XC 326-40	40	50.4	7.0	4.0	326
XC 327-45	45	55.4	7.0	4.0	327
XC 328-47	47	57.4	7.0	4.0	328
XC 329-50	50	60.4	7.0	4.0	329
XC 330-53	53	63.4	7.0	4.0	330
XC 331-57	57	67.4	7.0	4.0	331
XC 332-60	60	70.4	7.0	4.0	332
XC 333-63	63	73.4	7.0	4.0	333
XC 334-66	66	76.4	7.0	4.0	334
XC 335-70	70	80.4	7.0	4.0	335
XC 336-73	73	83.4	7.0	4.0	336
XC 337-75	75	85.4	7.0	4.0	337
XC 338-80	80	90.4	7.0	4.0	338
XC 339-82	82	92.4	7.0	4.0	339
XC 340-85	85	95.4	7.0	4.0	340
XC 341-90	90	100.4	7.0	4.0	341
XC 342-92	92	102.4	7.0	4.0	342
XC 343-95	95	105.4	7.0	4.0	343
XC 344-98	98	108.4	7.0	4.0	344

Part.	d <sup>f7</sup>	D <sup>H9</sup>	L <sup>+0.2</sup>	S	OR
XC 345-100	100	110.4	7.0	4.0	345
XC 346-104	104	114.4	7.0	4.0	346
XC 347-107	107	117.4	7.0	4.0	347
XC 348-111	111	121.4	7.0	4.0	348
XC 425-114	114	127.7	9.5	5.0	425
XC 426-117	117	130.7	9.5	5.0	426
XC 427-120	120	133.7	9.5	5.0	427
XC 428-123	123	136.7	9.5	5.0	428
XC 429-126	126	139.7	9.5	5.0	429
XC 430-130	130	143.7	9.5	5.0	430
XC 431-133	133	146.7	9.5	5.0	431
XC 432-136	136	149.7	9.5	5.0	432
XC 433-139	139	152.7	9.5	5.0	433
XC 434-142	142	155.7	9.5	5.0	434
XC 435-145	145	158.7	9.5	5.0	435
XC 436-149	149	162.7	9.5	5.0	436
XC 437-152	152	165.7	9.5	5.0	437
XC 438-158	158	171.7	9.5	5.0	438
XC 439-165	165	178.7	9.5	5.0	439
XC 440-170	170	183.7	9.5	5.0	440
XC 441-178	178	191.7	9.5	5.0	441
XC 442-184	184	197.7	9.5	5.0	442

Other sizes not present in the above table can be provided on request

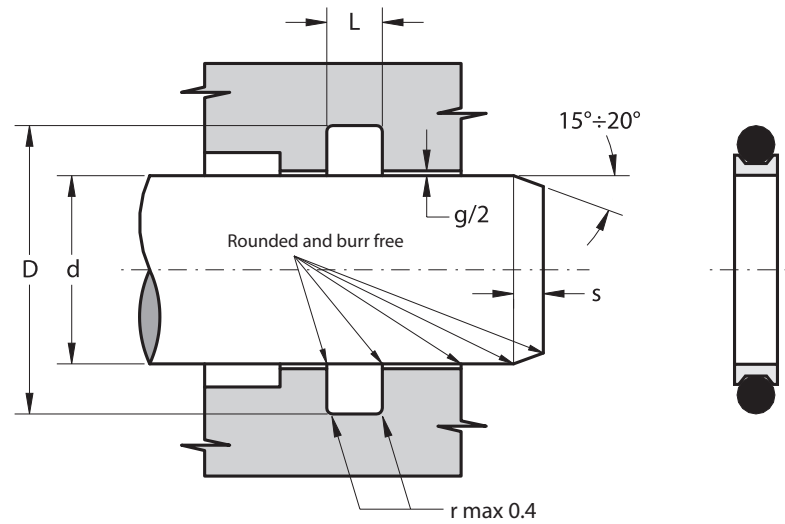

Part.	d <sup>f7</sup>	D <sup>H9</sup>	L <sup>+0.2</sup>	S	OR
<b>XC 443-190</b>	190	203.7	9.5	5.0	443
<b>XC 444-196</b>	196	209.7	9.5	5.0	444
<b>XC 445-203</b>	203	216.7	9.5	5.0	445
<b>XC 674-210</b>	210	223.7	9.5	5.0	674
<b>XC 446-215</b>	215	228.7	9.5	5.0	446
<b>XC 676-222</b>	222	235.7	9.5	5.0	676
<b>XC 447-230</b>	230	243.7	9.5	5.0	447
<b>XC 678-235</b>	235	248.7	9.5	5.0	678
<b>XC 448-240</b>	240	253.7	9.5	5.0	448
<b>XC 680-248</b>	248	261.7	9.5	5.0	680
<b>XC 449-255</b>	255	268.7	9.5	5.0	449
<b>XC 682-260</b>	260	273.7	9.5	5.0	682
<b>XC 450-265</b>	265	278.7	9.5	5.0	450

Part.	d <sup>f7</sup>	D <sup>H9</sup>	L <sup>+0.2</sup>	S	OR
<b>XC 684-273</b>	273	286.7	9.5	5.0	684
<b>XC 451-280</b>	280	293.7	9.5	5.0	451
<b>XC 686-285</b>	285	298.7	9.5	5.0	686
<b>XC 452-292</b>	292	305.7	9.5	5.0	452
<b>XC 688-300</b>	300	313.7	9.5	5.0	688
<b>XC 453-305</b>	305	318.7	9.5	5.0	453
<b>XC 454-318</b>	318	331.7	9.5	5.0	454
<b>XC 455-330</b>	330	343.7	9.5	5.0	455
<b>XC 456-342</b>	342	355.7	9.5	5.0	456
<b>XC 457-355</b>	355	368.7	9.5	5.0	457
<b>XC 458-370</b>	370	383.7	9.5	5.0	458
<b>XC 459-380</b>	380	393.7	9.5	5.0	459
<b>XC 460-393</b>	393	406.7	9.5	5.0	460

Other sizes not present in the above table can be provided on request



# KD

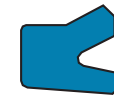

### MATERIAL

Type	Designation	Hardness
Polyurethane	SEALPUR 93	93 °ShA

### FIELD OF APPLICATION

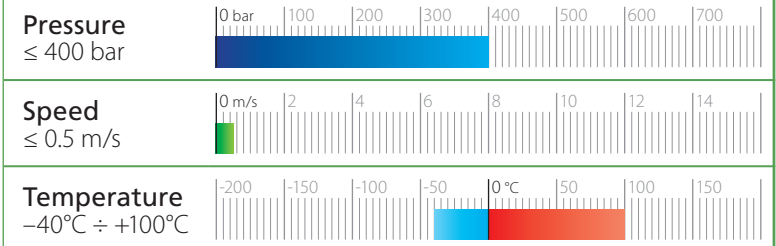

**Fluids** Hydraulic oils (mineral oil based)  
For other fluids contact our technical department

### SURFACE ROUGHNESS

<b>Dynamic surface</b>	Ra ≤ 0.3 µm	Rt ≤ 2.5 µm
<b>Static surface</b>	Ra ≤ 1.6 µm	Rt ≤ 6.3 µm

### GAP DIMENSION "g"

The largest gap dimension appearing in operation on the non-pressurised side:

50 bar	1.20 mm	300 bar	0.25 mm
100 bar	0.80 mm	400 bar	0.17 mm
200 bar	0.40 mm		

NB: for the Gap calculation, it is necessary to consider the elastic deformation of metal elements under pressure loads.

### LEAD-IN CHAMFERS

d	Smin
less 100	5 mm
100÷200	7 mm
over 200	10 mm

To avoid damaging the sealing lips during installation, housing must have rounded chamfers. Sharp edges and burrs within the installation area of the seal must be removed.

The above data are maximum values, they may be maintained for short periods and can not be used at the same time simultaneously.

The piston seal type Aston Seals KD assures a good reaction against shock pressure peaks and low friction in the low pressure range.

The asymmetric lips are designed to differentiate the behaviour of the lips on the static and dynamic surfaces: the static lip is flexible, more sensitive to pressure fluctuations and it guaranties a wide contact area; the dynamic lip is shorter and stronger to concentrate load against the dynamic surface.

They can also be used in back-to-back arrangement for double acting piston.

- Extended service life
- Simple groove design
- Insensitive to structural deflections

- High resistance against extrusion
- Excellent wear-resistance
- Good temperature resistance
- Easy installation without expensive auxiliaries

# KD

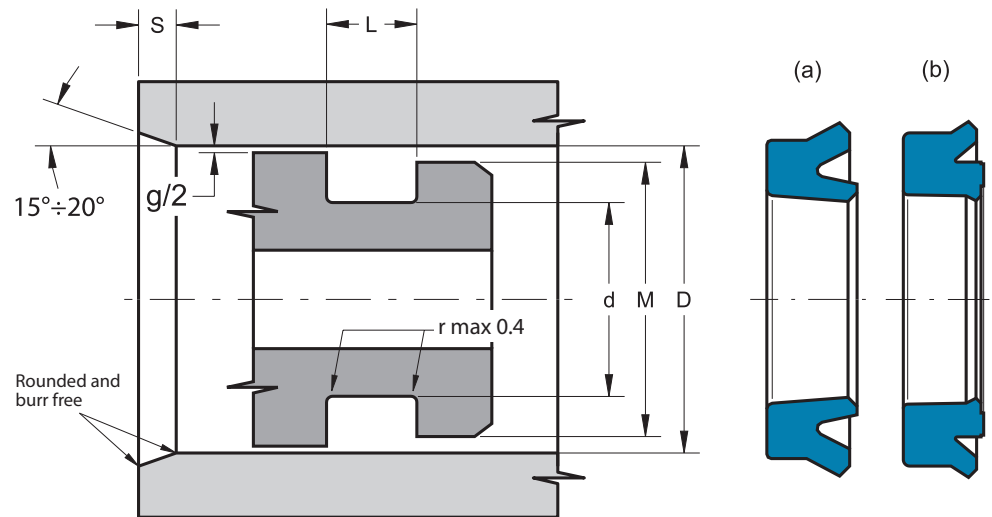

Part.	D <sup>H10</sup>	d <sup>f8</sup>	L <sup>+0.25</sup>	M	Tp.
<b>KD 11 4 8</b>	11	4	9.0	7	(a)
<b>KD 16 8 5.8</b>	16	8	6.3	11	(a)
<b>KD 16 10 5.7</b>	16	10	6.2	13	(a)
<b>KD 18 12.1 3.93</b>	18	12.1	4.43	15	(a)
<b>KD 20 10 7.5</b>	20	10	8.5	14	(a)
<b>KD 20 12 5.3</b>	20	12	5.8	15	(a)
<b>KD 22 12 8</b>	22	12	9.0	16	(a)
<b>KD 25 13 7</b>	25	13	8.0	17	(a)
<b>KD 25 15 8</b>	25	15	9.0	19	(a)
<b>KD 25 17 10</b>	25	17	11.0	21	(b)
<b>KD 30 15 10</b>	30	15	11.0	20	(a)
<b>KD 30 20 8</b>	30	20	9.0	24	(a)
<b>KD 30 22 6</b>	30	22	7.0	25	(a)
<b>KD 31.75 19 7</b>	31.75	19	8.0	24	(a)
<b>KD 32 17 10</b>	32	17	11.0	22	(a)
<b>KD 32 22 10</b>	32	22	11.0	26	(a)
<b>KD 32 26 5</b>	32	26	5.5	29	(a)
<b>KD 32 26 6</b>	32	26	7.0	29	(a)
<b>KD 35 20 10</b>	35	20	11.0	25	(a)
<b>KD 35 22.5 6</b>	35	22.5	7.0	27	(a)
<b>KD 35 25 8</b>	35	25	9.0	29	(a)
<b>KD 38 31 4.7</b>	38	31	5.2	34	(a)
<b>KD 40 25 10</b>	40	25	11.0	30	(a)
<b>KD 40 30 6.5</b>	40	30	7.5	34	(a)

Part.	D <sup>H10</sup>	d <sup>f8</sup>	L <sup>+0.25</sup>	M	Tp.
<b>KD 40 33 8</b>	40	33	9.0	36	(a)
<b>KD 42 32 10</b>	42	32	11.0	36	(a)
<b>KD 45 30 10</b>	45	30	11.0	35	(a)
<b>KD 46 39.4 4</b>	46	39.4	4.5	42	(a)
<b>KD 50 35 10</b>	50	35	11.0	40	(a)
<b>KD 50 40 5</b>	50	40	5.5	44	(a)
<b>KD 50 40 7.3</b>	50	40	8.3	44	(a)
<b>KD 50 40 10</b>	50	40	11.0	44	(a)
<b>KD 50 42 5.5</b>	50	42	6.0	45	(a)
<b>KD 50 42 8</b>	50	42	9.0	45	(a)
<b>KD 55 40 10</b>	55	40	11.0	45	(a)
<b>KD 55 45 6.5</b>	55	45	7.5	49	(a)
<b>KD 56 46 7</b>	56	46	8.0	50	(a)
<b>KD 60 40 12</b>	60	40	13.0	45	(a)
<b>KD 60 40 13.5</b>	60	40	14.5	45	(a)
<b>KD 60 45 10</b>	60	45	11.0	50	(a)
<b>KD 60 50 7</b>	60	50	8.0	54	(a)
<b>KD 63 45 10</b>	63	45	11.0	50	(a)
<b>KD 63 48 10</b>	63	48	11.0	53	(a)
<b>KD 63 48 12</b>	63	48	13.0	53	(a)
<b>KD 63 53 7</b>	63	53	8.0	57	(a)
<b>KD 65 45 12</b>	65	45	13.0	50	(a)
<b>KD 65 50 10</b>	65	50	11.0	55	(a)
<b>KD 65 55 10</b>	65	55	11.0	59	(a)

Part.	D <sup>H10</sup>	d <sup>f8</sup>	L <sup>+0.25</sup>	M	Tp.
<b>KD 70 50 12</b>	70	50	13.0	55	(a)
<b>KD 70 50 15</b>	70	50	16.0	55	(a)
<b>KD 70 60 7</b>	70	60	8.0	64	(a)
<b>KD 70 60 8</b>	70	60	9.0	64	(a)
<b>KD 70 60 12</b>	70	60	13.0	64	(a)
<b>KD 75 65 5</b>	75	65	5.5	69	(a)
<b>KD 75 65 7</b>	75	65	8.0	69	(a)
<b>KD 75 65 10</b>	75	65	11.0	69	(a)
<b>KD 75 65 12</b>	75	65	13.0	69	(a)
<b>KD 80 60 12</b>	80	60	13.0	65	(a)
<b>KD 80 60 13.5</b>	80	60	14.5	65	(a)
<b>KD 80 65 12</b>	80	65	13.0	70	(a)
<b>KD 80 70 7</b>	80	70	8.0	74	(a)
<b>KD 80 70 12</b>	80	70	13.0	74	(a)
<b>KD 85 65 13.5</b>	85	65	14.5	70	(a)
<b>KD 90 70 12</b>	90	70	13.0	75	(a)
<b>KD 90 70 13.5</b>	90	70	14.5	75	(a)
<b>KD 90 75 10</b>	90	75	11.0	80	(a)
<b>KD 90 75 12</b>	90	75	13.0	80	(a)
<b>KD 90 80 5</b>	90	80	5.5	84	(a)
<b>KD 90 80 10</b>	90	80	11.0	84	(a)
<b>KD 90 80 12</b>	90	80	13.0	84	(a)
<b>KD 95 85 7</b>	95	85	8.0	89	(a)
<b>KD 95 85 8.5</b>	95	85	9.5	89	(a)

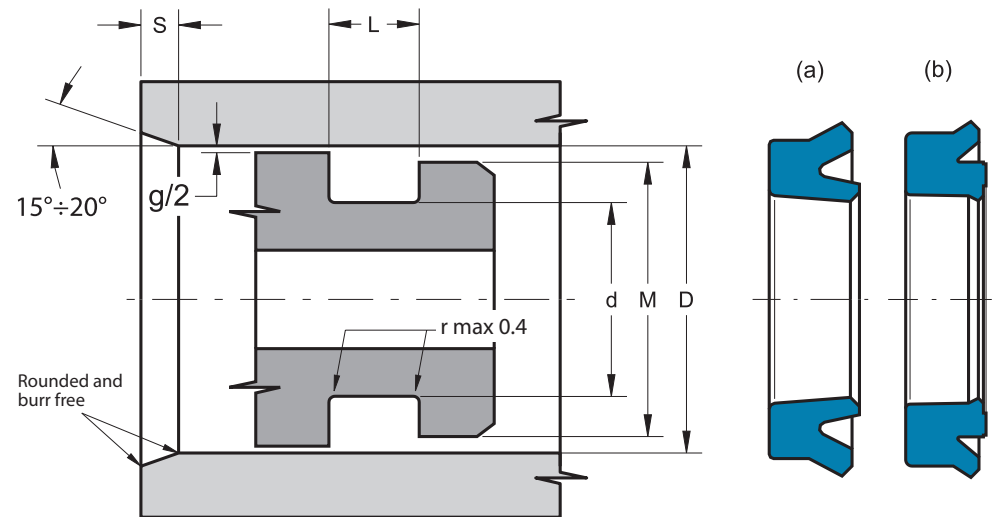

Part.	D <sup>H10</sup>	d <sup>f8</sup>	L <sup>+0.25</sup>	M	Tp.
<b>KD 95 87 4</b>	95	87	4.5	91	(a)
<b>KD 100 80 12</b>	100	80	13.0	85	(a)
<b>KD 100 85 12</b>	100	85	13.0	90	(a)
<b>KD 100 90 8</b>	100	90	9.0	94	(a)
<b>KD 105 85 12</b>	105	85	13.0	90	(a)
<b>KD 110 100 7</b>	110	100	8.0	104	(a)
<b>KD 120 100 12</b>	120	100	13.0	105	(a)
<b>KD 125 105 12</b>	125	105	13.0	110	(a)
<b>KD 160 140 8.25</b>	160	140	8.5	145	(a)
<b>KD 170 152 7</b>	170	152	8.0	157	(a)
<b>KD 180 160 13.5</b>	180	160	14.5	165	(a)
<b>KD 180 160 15</b>	180	160	16.0	174	(b)
<b>KD 190 172 7</b>	190	172	8.0	177	(a)
<b>KD 220 200 15</b>	220	200	16.0	214	(b)
<b>KD 250 220 18</b>	250	220	19.0	240	(b)

Inch sizes

<b>KD 3000 2385 0535</b>	76.20	60.60	14.6	66.2	(a)
<b>KD 4250 3640 0535</b>	107.95	92.45	14.6	97.9	(a)
<b>KD 8000 7000 0750</b>	203.2	177.8	20.0	174	(b)



# KDA



KDA

The piston seals type Aston Seals KDA is mainly used with high pressure and the backup ring offsets large gaps or structural deflections without extrusion.

The asymmetric lips are designed to differentiate the behaviour of the lips on the static and dynamic surfaces: the static lip is flexible, more sensitive to pressure fluctuations and it guaranties a wide contact area; the dynamic lip is shorter and stronger to concentrate load against the dynamic surface.

They can also be used in back-to-back arrangement for double acting piston.

- Very high resistance against extrusion (backup ring)

- Insensitive to structural deflections
- Extended service life
- Simple groove design
- Excellent wear-resistance
- Good temperature resistance
- Easy installation without expensive auxiliaries

## MATERIAL

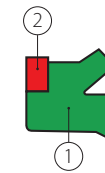

① Type	Polyurethane
① Designation	SEALPUR 94
① Hardness	94 °ShA
② Type	Acetal resin
② Designation	BEARITE

## FIELD OF APPLICATION

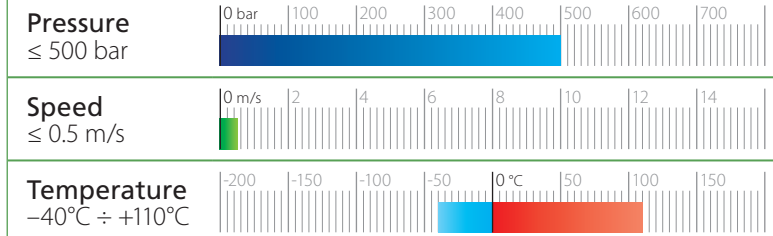

**Fluids** Hydraulic oils (mineral oil based)  
For other fluids contact our technical department

## SURFACE ROUGHNESS

<b>Dynamic surface</b>	Ra ≤ 0.3 μm	Rt ≤ 2.5 μm
<b>Static surface</b>	Ra ≤ 1.6 μm	Rt ≤ 6.3 μm

## GAP DIMENSION "g"

The largest gap dimension appearing in operation on the non-pressurised side:

200 bar	0.80 mm	400 bar	0.50 mm
300 bar	0.65 mm	500 bar	0.40 mm

NB: for the Gap calculation, it is necessary to consider the elastic deformation of metal elements under pressure loads.

## LEAD-IN CHAMFERS

d	Smin
less 100	5 mm
100÷200	7 mm
over 200	10 mm

To avoid damaging the sealing lips during installation, housing must have rounded chamfers. Sharp edges and burrs within the installation area of the seal must be removed.

The above data are maximum values, they may be maintained for short periods and can not be used at the same time simultaneously.



# KDA

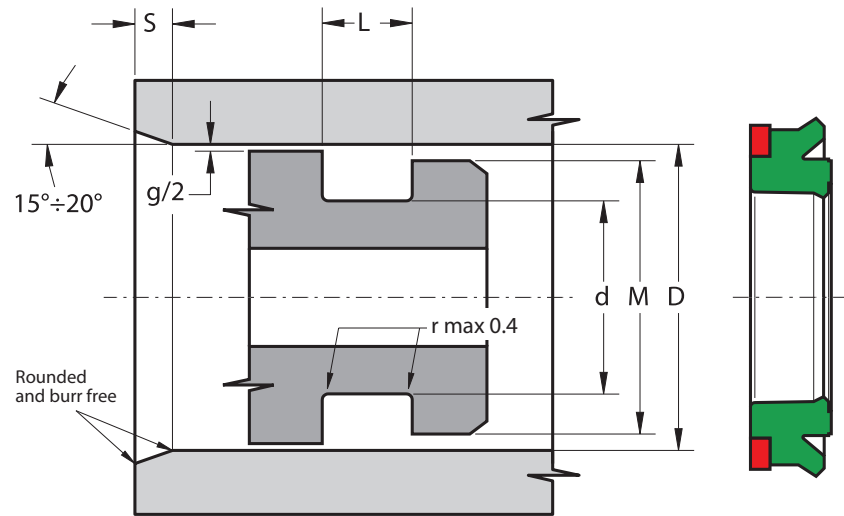

Part.	D <sup>H10</sup>	d <sup>f8</sup>	L <sup>+0.25</sup>	M
KDA 40 25 9	40	25	9.5	35
KDA 45 30 9	45	30	9.5	40
KDA 45 35 6	45	35	6.5	40
KDA 45 35 9	45	35	9.5	40
KDA 48 40 5.8	48	40	6.3	44
KDA 50 35 9	50	35	9.5	45
KDA 50 40 9	50	40	9.5	45
KDA 55 40 9	55	40	9.5	50
KDA 55 45 6	55	45	6.5	50
KDA 60 40 14	60	40	14.5	54
KDA 60 45 9	60	45	9.5	55
KDA 63 48 9	63	48	9.5	58
KDA 65 50 9	65	50	9.5	60
KDA 70 50 12	70	50	12.5	64
KDA 70 55 9	70	55	9.5	64
KDA 75 55 12	75	55	12.5	69
KDA 80 60 12	80	60	12.5	74
KDA 80 60 14	80	60	14.5	74

Part.	D <sup>H10</sup>	d <sup>f8</sup>	L <sup>+0.25</sup>	M
KDA 80 65 9	80	65	9.5	75
KDA 85 69.9 5.8	85	69.9	6.3	75
KDA 85 70 9	85	70	9.5	80
KDA 90 70 12	90	70	12.5	84
KDA 90 75 9	90	75	9.5	85
KDA 100 80 12	100	80	12.5	94
KDA 100 84.5 5.8	100	84.5	6.3	90
KDA 100 85 9	100	85	9.5	95
KDA 100 85 14	100	85	14.5	95
KDA 105 85 12	105	85	12.5	99
KDA 110 90 12	110	90	12.5	104
KDA 110 95 9	110	95	9.5	105
KDA 115 95 12	115	95	12.5	109
KDA 120 104.5 5.8	120	104.5	6.3	110
KDA 120 105 9	120	105	9.5	115
KDA 125 100 15	125	100	15.5	117
KDA 125 105 12	125	105	12.5	119
KDA 130 110 12	130	110	12.5	124

Part.	D <sup>H10</sup>	d <sup>f8</sup>	L <sup>+0.25</sup>	M
KDA 130 114.5 5.8	130	114.5	6.3	120
KDA 140 115 15	140	115	15.5	132
KDA 140 120 12	140	120	12.5	134
KDA 145 125 15	145	125	15.5	139
KDA 150 120 18.5	150	120	19.0	140
KDA 150 130 12	150	130	12.5	144
KDA 160 130 18.5	160	130	19.0	150
KDA 160 140 12	160	140	12.5	154
KDA 170 150 12	170	150	12.5	164
KDA 180 150 18.5	180	150	19.0	170
KDA 180 160 12	180	160	12.5	174
KDA 190 170 12	190	170	12.5	184
KDA 198 178 12.5	198	178	13.0	192
KDA 200 170 18.5	200	170	19.0	190
KDA 200 175 15	200	175	15.5	192
KDA 220 200 15	220	200	15.5	214
KDA 250 220 18.5	250	220	19.0	240
KDA 250 225 15	250	225	15.5	242

# KDF

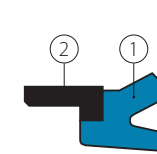
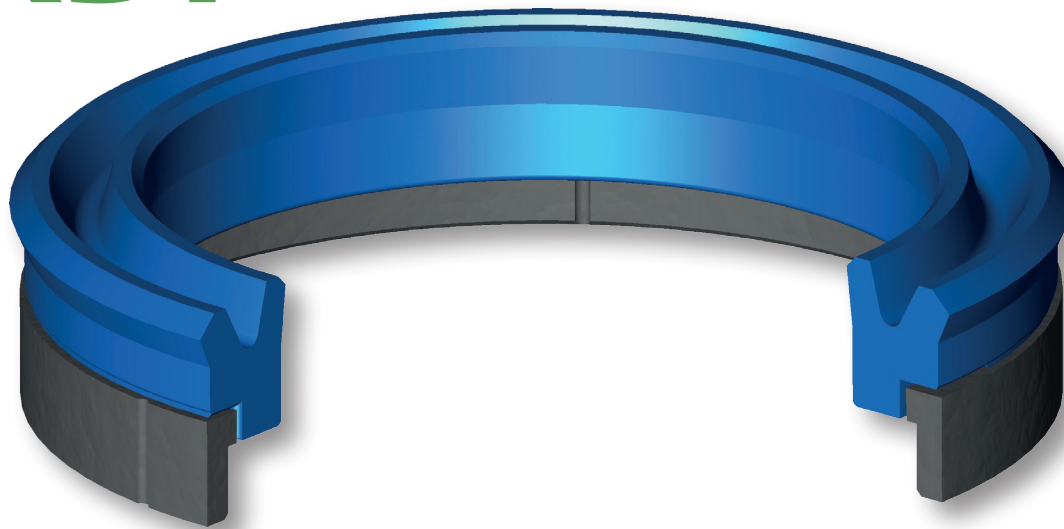

MATERIAL	
① Type	Polyurethane
① Designation	SEALPUR 93
① Hardness	93 °ShA
② Type	Acetal resin with glass fibre
② Designation	BEARITE

### FIELD OF APPLICATION

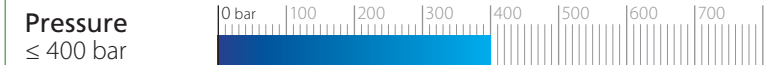

**Fluids**  
Hydraulic oils (mineral oil based)  
For other fluids contact our technical department

### SURFACE ROUGHNESS

<b>Dynamic surface</b>	Ra ≤ 0.3 µm	Rt ≤ 2.5 µm
<b>Static surface</b>	Ra ≤ 1.6 µm	Rt ≤ 6.3 µm

### LEAD-IN CHAMFERS

d	Smin
less 100	5 mm
100÷200	7 mm
over 200	10 mm

To avoid damaging the sealing lips during installation, housing must have rounded chamfers. Sharp edges and burrs within the installation area of the seal must be removed.

The above data are maximum values, they may be maintained for short periods and can not be used at the same time simultaneously.

The piston seal type Aston Seals KDF is composed of:

- A seal element which assures a good reaction against shock pressure peaks and low friction in the low pressure range. The asymmetric lips are designed to differentiate the behaviour of the lips on the static and dynamic surfaces. The static lip is flexible, more sensitive to pressure fluctuations and it guaranties a wide contact area. The dynamic lip is shorter and stronger to concentrate load against the dynamic surface
- An angular wear ring which guides the piston in the cylinder and supports radial loads
- Simple groove design

- Inexpensive sealing and guiding solution
- Extended service life
- High resistance against extrusion
- Excellent wear-resistance
- Good temperature resistance
- Easy installation without expensive auxiliaries

# KDF

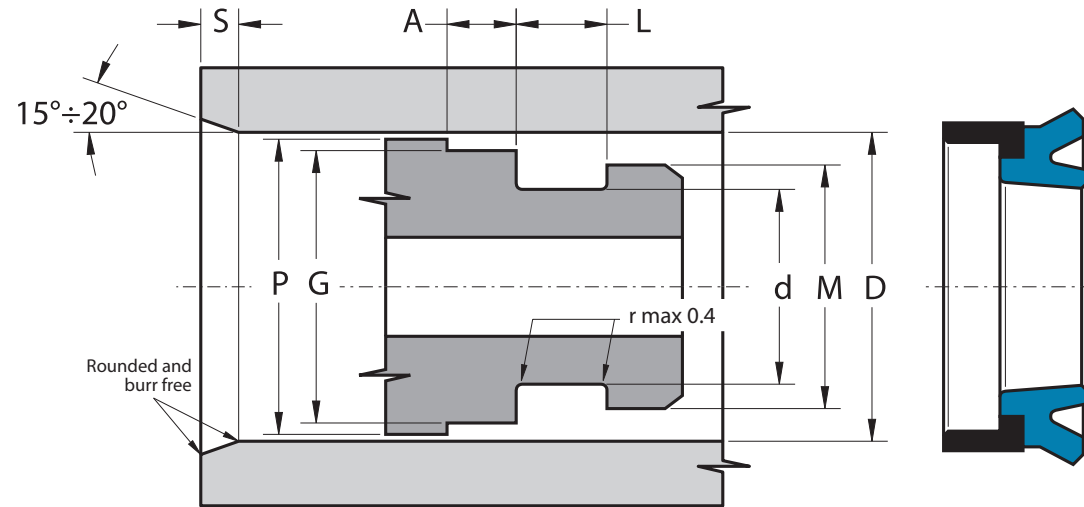

Part.	D <sup>H10</sup>	d <sup>f8</sup>	L <sup>+0.25</sup>	A <sup>±0.1</sup>	G <sup>-0.05</sup>	P <sup>±0.2</sup>	M
<b>KDF 32 20 8</b>	32	20	9.0	6.35	28.50	30.5	24
<b>KDF 35 22 9</b>	35	22	10.0	6.35	31.40	33.5	27
<b>KDF 40 25 8.5</b>	40	25	9.5	6.35	35.40	38.5	30
<b>KDF 40 26 8.5</b>	40	26	9.5	6.35	35.40	38.5	31
<b>KDF 40 30 8</b>	40	30	9.0	6.35	35.40	38.5	34
<b>KDF 40 30 8.5</b>	40	30	9.5	6.35	35.40	38.5	34
<b>KDF 45 30 9</b>	45	30	10.0	6.35	40.40	43.7	35
<b>KDF 45 35 8.5</b>	45	35	9.5	6.35	40.40	43.7	39
<b>KDF 50 30 13.5</b>	50	30	14.5	6.35	44.30	48.5	35
<b>KDF 50 35 10</b>	50	35	11.0	6.35	45.35	48.5	40
<b>KDF 50 40 10</b>	50	40	11.0	6.35	45.40	48.5	44
<b>KDF 55 40 10</b>	55	40	11.0	6.35	50.35	53.5	45
<b>KDF 60 40 13.5</b>	60	40	14.5	6.35	55.40	58.5	45

Part.	D <sup>H10</sup>	d <sup>f8</sup>	L <sup>+0.25</sup>	A <sup>±0.1</sup>	G <sup>-0.05</sup>	P <sup>±0.2</sup>	M
<b>KDF 60 45 10</b>	60	45	11.0	6.35	55.40	58.5	50
<b>KDF 63 45 10</b>	63	45	11.0	6.35	58.40	61.5	50
<b>KDF 65 50 10</b>	65	50	11.0	6.35	60.40	63.5	55
<b>KDF 70 50 13.5</b>	70	50	14.5	6.35	64.20	68.3	55
<b>KDF 80 60 12</b>	80	60	13.0	6.35	74.15	78.3	65
<b>KDF 80 60 13.5</b>	80	60	14.5	6.35	74.15	78.3	65
<b>KDF 90 70 12</b>	90	70	13.0	6.35	84.15	88.3	75
<b>KDF 90 70 13.5</b>	90	70	14.5	6.35	84.15	88.3	75
<b>KDF 100 80 13.5</b>	100	80	14.5	6.35	93.15	98.0	85
<b>KDF 100 80 13.5/A</b>	100	80	14.5	6.35	94.15	98.3	85
<b>KDF 110 95 12</b>	110	95	13.0	6.35	103.10	108.0	100
<b>KDF 120 100 13.5</b>	120	100	14.5	6.35	113.10	118.1	105

# SP



## MATERIAL



**Type**  
Acetal resin

**Designation**  
BEARITE

## FIELD OF APPLICATION

**Temperature**  
-40°C ÷ +110°C

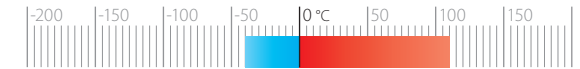

**Fluids**

Hydraulic oils (mineral oil based)  
For other fluids contact our technical department

## LEAD-IN CHAMFERS

d	Smin
less 100	5 mm
100÷200	7 mm
over 200	10 mm

To avoid breaking or damaging, the retaining ring should be warmed in water before the installation.

The above data are maximum values, they may be maintained for short periods and can not be used at the same time simultaneously.

The retaining ring type Aston Seals SP helps the assembly in the open groove of the piston seal, especially those with a large radial section.

- Easy installation of piston seal
- Simple groove design
- Good temperature resistance

SP

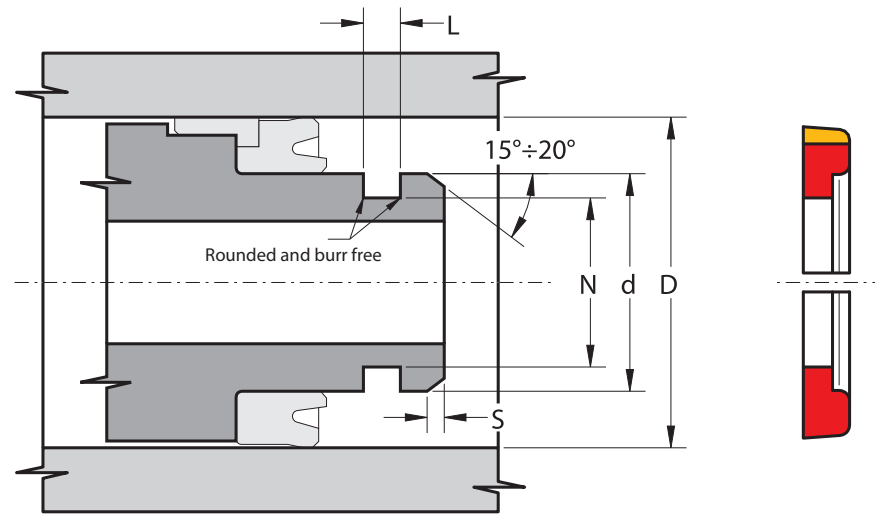

Part.	D <sup>H10</sup>	d <sup>+0.1</sup>	N <sup>±0.1</sup>	L <sup>-0.2/+0.1</sup>
SP 32 20	32	20	15.80	3.10
SP 35 22	35	22	17.80	3.10
SP 40 26	40	26	21.60	3.10
SP 45 30	45	30	25.80	3.10
SP 50 30	50	30	25.80	3.35
SP 55 40	55	40	35.80	3.10
SP 60 40	60	40	36.10	3.35
SP 63 45	63	45	40.84	3.10
SP 70 50	70	50	45.84	3.35
SP 80 60	80	60	55.80	3.35
SP 90 70	90	70	66.10	3.35

# KPD



KPD

The piston seal type Aston Seals KPD is composed of:

- A dynamic seal element which assures exceptional high sealing performance. Two compact and small seal edges ensure perfect fluid control and concentrate the load against the dynamic surface. The cavity between the two external seal edges keeps a small quantity of fluid which reduces friction and wear. Side grooves ensure that pressure loads the energizing O-Ring in all work conditions
- A standard size O-Ring with low permanent deformation as energizing component on the static side
- High sealing performance at low pressure

- also
- Excellent wear-resistance
  - Space-saving construction
  - Can also work for single action
  - Extended service life
  - Simple groove design
  - Low cost solution
  - High resistance against extrusion
  - Good temperature resistance
  - Easy installation on a solid piston

## MATERIAL

	① <b>Type</b>	Polyurethane
	<b>Designation</b>	SEALPUR 97
	<b>Hardness</b>	97 °ShA
	② <b>Type</b>	Nitril Rubber NBR
	<b>Designation</b>	RUBSEAL 70
	<b>Hardness</b>	70 °ShA

## FIELD OF APPLICATION

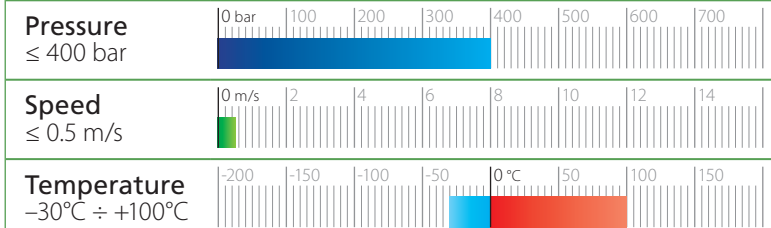

**Fluids** Hydraulic oils (mineral oil based)  
For other fluids contact our technical department

## SURFACE ROUGHNESS

<b>Dynamic surface</b>	Ra ≤ 0.3 μm	Rt ≤ 2.5 μm
<b>Static surface</b>	Ra ≤ 1.6 μm	Rt ≤ 6.3 μm

## GAP DIMENSION "g"

The largest gap dimension appearing in operation on the non-pressurised side:

50 bar	1.20 mm	300 bar	0.25 mm
100 bar	0.80 mm	400 bar	0.17 mm
200 bar	0.40 mm		

NB: for the Gap calculation, it is necessary to consider the elastic deformation of metal elements under pressure loads.

## LEAD-IN CHAMFERS

d	Smin
less 100	5 mm
100÷200	7 mm
over 200	10 mm

To avoid damaging the sealing lips during installation, housing must have rounded chamfers. Sharp edges and burrs within the installation area of the seal must be removed.

The above data are maximum values, they may be maintained for short periods and can not be used at the same time simultaneously.

# KPD

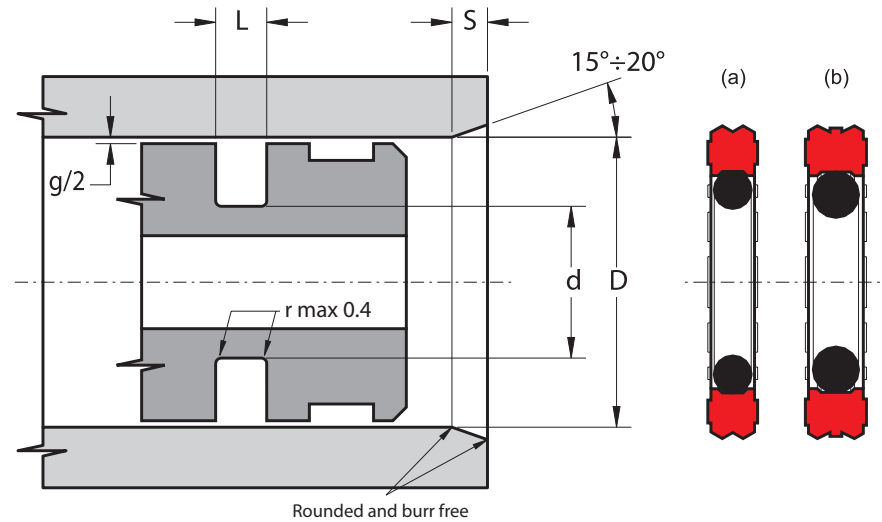

Part.	D <sup>H10</sup>	d <sup>+0.1</sup>	L <sup>+0.2</sup>	OR	Tp.
KPD 15 7.5 3.2	15	7.5	3.2	108	(a)
KPD 16 8.5 3.2	16	8.5	3.2	109	(a)
KPD 16 11.1 2.2	16	11.1	2.2	013	(a)
KPD 18 10.5 3.2	18	10.5	3.2	110	(a)
KPD 20 12.5 3.2	20	12.5	3.2	112	(a)
KPD 22 14.5 3.2	22	14.5	3.2	113	(a)
KPD 25 14.4 4.2	25	14.0	4.2	207	(b)
KPD 25 17.5 3.2	25	17.5	3.2	115	(a)
KPD 30 22.5 3.2	30	22.5	3.2	118	(a)
KPD 30 25.1 2.2	30	25.1	2.2	021	(a)
KPD 32 21 4.2	32	21.0	4.2	211	(b)
KPD 32 24.5 3.2	32	24.5	3.2	119	(a)
KPD 35 24 4.2	35	24.0	4.2	213	(b)
KPD 35 27.5 3.2	35	27.5	3.2	121	(a)
KPD 36 28.5 3.2	36	28.5	3.2	122	(a)
KPD 38 30.5 3.2	38	30.5	3.2	123	(a)
KPD 40 24.5 6.3	40	24.5	6.3	317	(b)
KPD 40 29 4.2	40	29.0	4.2	216	(b)
KPD 40 32.5 3.2	40	32.5	3.2	124	(a)
KPD 42 31 4.2	42	31.0	4.2	217	(b)
KPD 45 29.5 6.3	45	29.5	6.3	320	(b)
KPD 45 34 4.2	45	34.0	4.2	219	(b)
KPD 48 37 4.2	48	37.0	4.2	221	(b)

Part.	D <sup>H10</sup>	d <sup>+0.1</sup>	L <sup>+0.2</sup>	OR	Tp.
KPD 49 38 4.2	49	38.0	4.2	222	(b)
KPD 50 34.5 6.3	50	34.5	6.3	324	(b)
KPD 50 39 4.2	50	39.0	4.2	222	(b)
KPD 52 36.5 6.3	52	36.5	6.3	324	(b)
KPD 54 43 4.2	54	43.0	4.2	826	(b)
KPD 55 39.5 6.3	55	39.5	6.3	325	(b)
KPD 55 44 4.2	55	44.0	4.2	224	(b)
KPD 57.16 47.6 4.8	57.16	47.6	4.8	47x4	(b)
KPD 57 46 4.2	57	46.0	4.2	827	(b)
KPD 60 44.5 6.3	60	44.5	6.3	327	(b)
KPD 60 49 4.2	60	49.0	4.2	225	(b)
KPD 63 47.5 6.3	63	47.5	6.3	328	(b)
KPD 63 52 4.2	63	52.0	4.2	226	(b)
KPD 65 49.5 6.3	65	49.5	6.3	328	(b)
KPD 65 54 4.2	65	54.0	4.2	227	(b)
KPD 70 54.5 6.3	70	54.5	6.3	330	(b)
KPD 70 59 4.2	70	59.0	4.2	228	(b)
KPD 75 59.5 6.3	75	59.5	6.3	331	(b)
KPD 75 64 4.2	75	64.0	4.2	230	(b)
KPD 76.2 62.53 7.18	76.2	62.53	7.18	62.3x5.7	(b)
KPD 80 64.5 6.3	80	64.5	6.3	333	(b)
KPD 80 69 4.2	80	69.0	4.2	842	(b)
KPD 85 69.5 6.3	85	69.5	6.3	335	(b)

Part.	D <sup>H10</sup>	d <sup>+0.1</sup>	L <sup>+0.2</sup>	OR	Tp.
KPD 88 72.5 6.3	88	72.5	6.3	335	(b)
KPD 90 69 8.1	90	69.0	8.1	68x7	(b)
KPD 90 74.5 6.3	90	74.5	6.3	336	(b)
KPD 90 79 4.2	90	79.0	4.2	235	(b)
KPD 95 79.5 6.3	95	79.5	6.3	338	(b)
KPD 100 84.5 6.3	100	84.5	6.3	339	(b)
KPD 105 89.5 6.3	105	89.5	6.3	341	(b)
KPD 110 94.5 6.3	110	94.5	6.3	343	(b)
KPD 115 94 8.1	115	94.0	8.1	94x7	(b)
KPD 115 99.5 6.3	115	99.5	6.3	344	(b)
KPD 120 104.5 6.3	120	104.5	6.3	346	(b)
KPD 125 109.5 6.3	125	109.5	6.3	347	(b)
KPD 130 114.5 6.3	130	114.5	6.3	349	(b)
KPD 140 119 8.1	140	119.0	8.1	426	(b)
KPD 140 124.5 6.3	140	124.5	6.3	352	(b)
KPD 150 129 8.1	150	129.0	8.1	429	(b)
KPD 160 139 8.1	160	139.0	8.1	433	(b)
KPD 170 149 8.1	170	149.0	8.1	436	(b)
KPD 180 159 8.1	180	159.0	8.1	438	(b)
KPD 200 179 8.1	200	179.0	8.1	441	(b)
KPD 220 199 8.1	220	199.0	8.1	444	(b)
KPD 250 229 8.1	250	229.0	8.1	447	(b)

# KPR



KPR

## MATERIAL

	① <b>Type</b>	Polyurethane
	<b>Designation</b>	SEALPUR 97
	<b>Hardness</b>	97 °ShA
	② <b>Type</b>	Nitril Rubber NBR
	<b>Designation</b>	RUBSEAL 80
	<b>Hardness</b>	80 °ShA

## FIELD OF APPLICATION

<b>Pressure</b> ≤ 400 bar	
<b>Speed</b> ≤ 0.5 m/s	
<b>Temperature</b> -30°C ÷ +100°C	
<b>Fluids</b>	Hydraulic oils (mineral oil based) For other fluids contact our technical department

## SURFACE ROUGHNESS

<b>Dynamic surface</b>	Ra ≤ 0.3 µm	Rt ≤ 2.5 µm
<b>Static surface</b>	Ra ≤ 1.6 µm	Rt ≤ 6.3 µm

## GAP DIMENSION "g"

The largest gap dimension appearing in operation on the non-pressurised side:

50 bar	1.20 mm	300 bar	0.25 mm
100 bar	0.80 mm	400 bar	0.17 mm
200 bar	0.40 mm		

NB: for the Gap calculation, it is necessary to consider the elastic deformation of metal elements under pressure loads.

## LEAD-IN CHAMFERS

d	Smin
less 100	5 mm
100÷200	7 mm
over 200	10 mm

To avoid damaging the sealing lips during installation, housing must have rounded chamfers. Sharp edges and burrs within the installation area of the seal must be removed.

The above data are maximum values, they may be maintained for short periods and can not be used at the same time simultaneously.

The piston seal type Aston Seals KPR is composed of:

- A dynamic seal element which assures exceptional high sealing performance. Two compact and small seal edges ensure perfect fluid control and concentrate the load against the dynamic surface. The cavity between the two external seal edges keeps a small quantity of fluid which reduces friction and wear. Side grooves ensure that pressure loads the energizing element in all work conditions.
- A nitril rubber element with low permanent deformation as energizing component on the static side. The hardness and the rectangular cross-section prevent twisting of the static element in the groove.

- High sealing performance at low pressure also
- Excellent wear-resistance
- Space-saving construction
- Can also work for single action
- Extended service life
- Simple groove design
- Low cost solution
- High resistance against extrusion
- Good temperature resistance
- Easy installation on a solid piston



# KPR

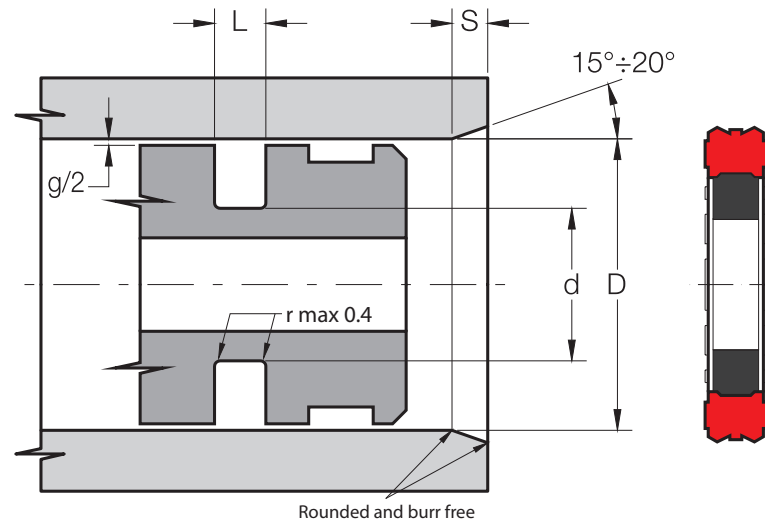

Part.	D <sup>H10</sup>	d <sup>+0.1</sup>	L <sup>+0.2</sup>
<b>KPR 63 52 4.2</b>	63	52.0	4.2
<b>KPR 70 59 4.2</b>	70	59.0	4.2
<b>KPR 80 64.5 6.3</b>	80	64.5	6.3
<b>KPR 90 69 8.1</b>	90	69.0	8.1
<b>KPR 90 74.5 6.3</b>	90	74.5	6.3
<b>KPR 100 84.5 6.3</b>	100	84.5	6.3
<b>KPR 110 94.5 6.3</b>	110	94.5	6.3
<b>KPR 120 104.5 6.3</b>	120	104.5	6.3

# KGD

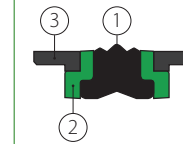
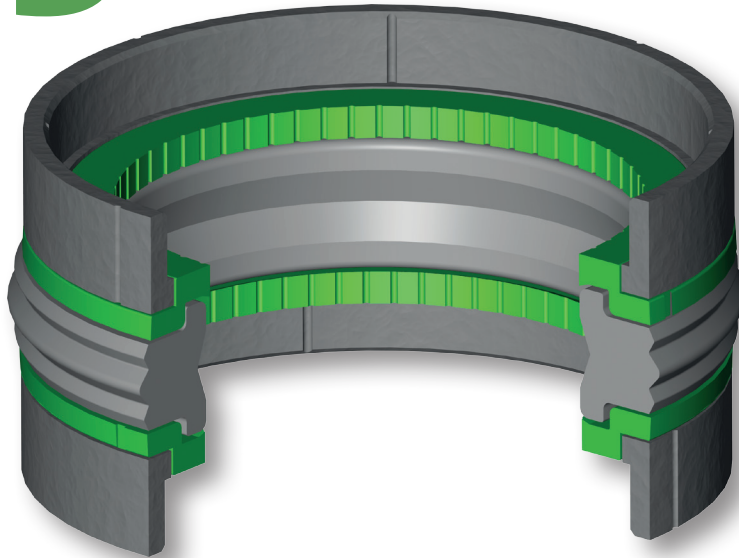

## MATERIAL

①	Type	Nitril Rubber NBR
	Designation	RUBSEAL 75
	Hardness	75 °ShA
②	Type	Thermoplastic polyester resin
	Designation	SEALITE 63
	Hardness	63 °ShD
③	Type	Acetal resin with glass fibre
	Designation	BEARITE

## FIELD OF APPLICATION

Pressure ≤ 400 bar	0 bar   100   200   300   400   500   600   700
Speed ≤ 0.5 m/s	0 m/s   2   4   6   8   10   12   14
Temperature -40°C ÷ +110°C	-200   -150   -100   -50   0 °C   50   100   150
Fluids	Hydraulic oils (mineral oil based) For other fluids contact our technical department

## SURFACE ROUGHNESS

Dynamic surface	Ra ≤ 0.3 µm	Rt ≤ 2.5 µm
Static surface	Ra ≤ 1.6 µm	Rt ≤ 6.3 µm

## LEAD-IN CHAMFERS

d	Smin
less 100	5 mm
100÷200	7 mm
over 200	10 mm

To avoid damaging the sealing lips during installation, housing must have rounded chamfers. Sharp edges and burrs within the installation area of the seal must be removed.

The above data are maximum values, they may be maintained for short periods and can not be used at the same time simultaneously.

The piston seal type Aston Seals KGD is composed of:

- A sealing rubber element with low permanent deformation which assures good sealing performance. Three compact and small seal edges ensure perfect fluid control and concentrate load against the dynamic surface. The cavities between the external seal edges keep small quantities of fluid reducing friction and wear. The special geometry of static side guaranties a wide contact area and prevents distortion inside the groove during installation
- Two anti-extrusion rings with stabilizers to avoid the rotation of the rubber element. A special geometry of grooves assures that pressure loads the energizing seal element without any risk of extrusion of it.

- Two angular wear rings which guide the piston in the cylinder tube and support radial loads. Special grooves ensure that pressure loads the energizing seal element in all work conditions
- Good sealing performance as well as at low pressure
- Simple one-part piston design
- High resistance against extrusion
- Good guide of piston and gap balancing
- Perfect fluid control
- Good mechanical stability at high temperature
- Easy installation without expensive auxiliaries
- Good temperature resistance
- Easy installation on a solid piston

# KGD

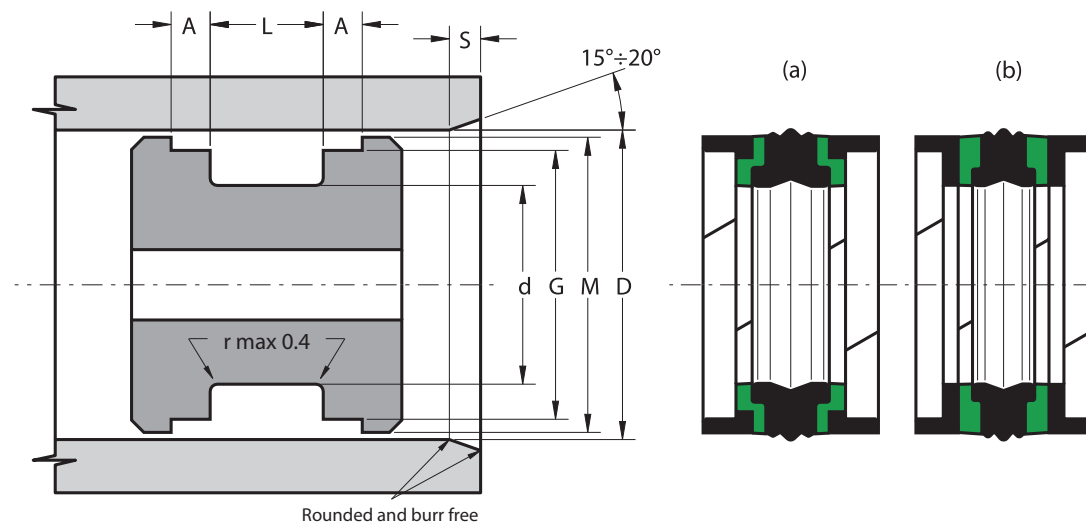

Part.	D <sup>H10</sup>	d <sup>+0.1</sup>	L <sup>+0.2</sup>	A <sup>±0.1</sup>	G <sup>-0.05</sup>	M <sup>±0.2</sup>	Tp.
KGD 20 11	20	11	13.5	2.10	17.00	19.0	(a)
KGD 25 15	25	15	16.4	6.35	21.45	23.5	(a)
KGD 25 15/A	25	15	12.0	4.00	21.00	23.0	(a)
KGD 25 15/B	25	15	12.5	4.00	22.00	24.0	(a)
KGD 25 16	25	16	13.5	2.10	22.00	24.0	(a)
KGD 25 17	25	17	10.0	4.00	22.00	24.0	(a)
KGD 25 17/A	25	17	13.5	3.20	21.00	24.0	(a)
KGD 30 17	30	17	15.4	6.35	26.50	29.0	(a)
KGD 30 21	30	21	13.5	2.10	27.00	29.0	(a)
KGD 32 22	32	22	16.4	6.35	28.50	30.5	(a)
KGD 32 22/A	32	22	15.5	2.60	28.00	31.0	(a)
KGD 32 22/C	32	22	12.5	4.00	29.00	31.0	(a)
KGD 32 24	32	24	15.5	3.20	28.00	31.4	(b)
KGD 32 24/A	32	24	10.0	4.00	29.00	31.0	(a)
KGD 35 25	35	25	16.4	6.35	31.40	33.5	(a)
KGD 35 25/A	35	25	15.5	2.60	31.00	34.0	(a)
KGD 40 24	40	24	18.4	6.35	35.40	38.5	(a)
KGD 40 26	40	26	15.5	2.60	36.00	39.0	(a)
KGD 40 30	40	30	16.4	6.35	35.40	38.5	(a)
KGD 40 30/A	40	30	12.5	4.00	36.00	38.0	(a)
KGD 40 30/B	40	30	12.5	4.00	37.00	39.0	(a)
KGD 40 32	40	32	15.5	3.20	36.00	39.4	(a)
KGD 40 32/A	40	32	10.0	4.00	37.00	39.0	(a)
KGD 45 29	45	29	18.4	6.35	40.40	43.7	(a)

Part.	D <sup>H10</sup>	d <sup>+0.1</sup>	L <sup>+0.2</sup>	A <sup>±0.1</sup>	G <sup>-0.05</sup>	M <sup>±0.2</sup>	Tp.
KGD 45 31	45	31	15.5	2.60	41.00	44.0	(a)
KGD 45 35	45	35	16.4	6.35	40.40	43.5	(a)
KGD 50 34	50	34	18.4	6.35	45.40	48.5	(a)
KGD 50 34/A	50	34	20.5	3.10	46.00	49.0	(a)
KGD 50 35	50	35	20.0	5.00	46.00	48.5	(a)
KGD 50 38	50	38	20.5	4.20	46.00	49.4	(a)
KGD 50 40	50	40	12.5	4.00	47.00	49.0	(a)
KGD 55 39	55	39	18.4	6.35	50.36	53.5	(a)
KGD 55 39/A	55	39	20.5	3.10	51.00	54.0	(a)
KGD 55 43	55	43	20.5	4.20	51.00	54.4	(b)
KGD 55 45	55	45	12.5	4.00	52.00	54.0	(a)
KGD 60 44	60	44	18.4	6.35	55.40	58.5	(a)
KGD 60 44/A	60	44	20.5	3.10	56.00	59.0	(a)
KGD 60 48	60	48	20.5	4.20	56.00	59.4	(b)
KGD 63 47	63	47	18.4	6.35	58.40	61.5	(a)
KGD 63 47/A	63	47	20.5	3.10	59.00	62.0	(a)
KGD 63 47/B	63	47	19.4	6.35	58.40	61.5	(a)
KGD 63 48	63	48	20.0	5.00	59.00	61.5	(a)
KGD 63 51	63	51	20.5	4.20	59.00	62.4	(a)
KGD 63 53	63	53	12.5	4.00	60.00	62.0	(a)
KGD 65 49	65	49	20.5	3.10	61.00	64.0	(a)
KGD 65 50	65	50	18.4	6.35	60.40	63.5	(a)
KGD 70 50	70	50	22.4	6.35	64.20	68.3	(a)
KGD 70 54	70	54	20.5	3.10	66.00	69.0	(a)

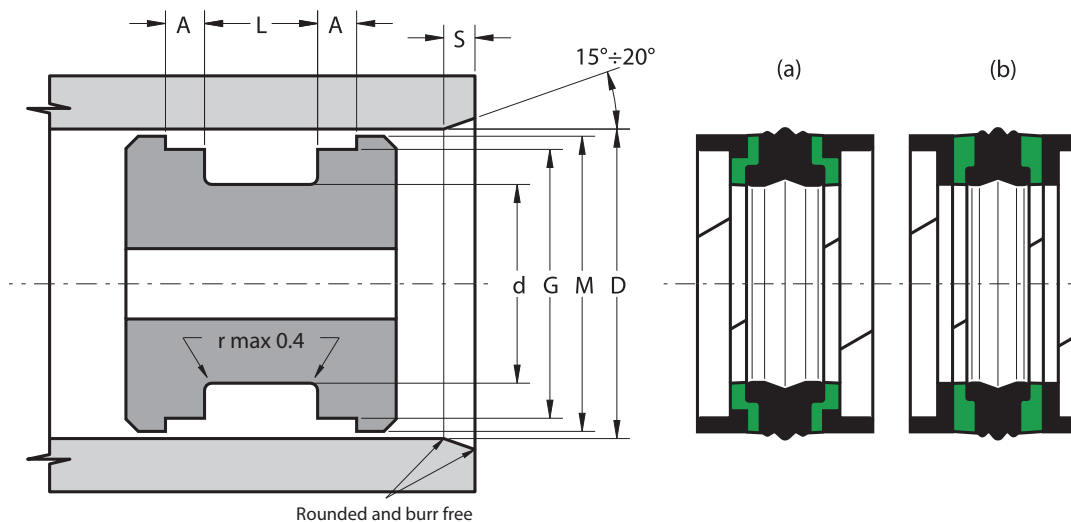

Part.	D <sup>H10</sup>	d <sup>+0.1</sup>	L <sup>+0.2</sup>	A <sup>±0.1</sup>	G <sup>-0.05</sup>	M <sup>±0.2</sup>	Tp.
<b>KGD 70 55</b>	70	55	20.0	5.00	66.00	68.5	(a)
<b>KGD 70 58</b>	70	58	20.5	4.20	66.00	69.4	(a)
<b>KGD 75 55</b>	75	55	22.4	6.35	69.20	73.3	(a)
<b>KGD 75 59</b>	75	59	20.5	3.10	71.00	74.0	(a)
<b>KGD 80 60</b>	80	60	22.4	6.35	74.15	78.3	(a)
<b>KGD 80 60/C</b>	80	60	25.0	6.35	75.00	78.0	(a)
<b>KGD 80 62</b>	80	62	22.5	3.60	76.00	79.0	(a)
<b>KGD 80 65</b>	80	65	20.0	5.00	76.00	78.5	(a)
<b>KGD 80 66</b>	80	66	22.5	5.20	76.00	79.4	(a)
<b>KGD 85 65</b>	85	65	22.4	6.35	79.15	83.3	(a)
<b>KGD 90 70</b>	90	70	22.4	6.35	84.15	88.3	(a)
<b>KGD 90 72</b>	90	72	22.5	3.60	86.00	89.0	(a)
<b>KGD 90 75</b>	90	75	20.0	5.00	86.00	88.5	(a)
<b>KGD 90 76</b>	90	76	22.5	5.20	86.00	89.4	(b)
<b>KGD 95 75</b>	95	75	22.4	6.35	89.15	93.3	(a)
<b>KGD 100 75</b>	100	75	22.4	6.35	93.15	98.0	(a)
<b>KGD 100 80</b>	100	80	25.4	6.35	94.15	98.3	(a)
<b>KGD 100 80/D</b>	100	80	25.0	6.35	95.00	98.0	(a)
<b>KGD 100 82</b>	100	82	22.5	3.60	96.00	99.0	(a)
<b>KGD 100 85</b>	100	85	20.0	5.00	96.00	98.5	(a)
<b>KGD 100 86</b>	100	86	22.5	5.20	96.00	99.4	(a)
<b>KGD 105 80</b>	105	80	22.4	6.35	98.10	103.0	(a)
<b>KGD 110 85</b>	110	85	22.4	6.35	103.10	108.0	(a)
<b>KGD 110 85/A</b>	110	85	25.4	6.35	103.10	108.0	(a)

Part.	D <sup>H10</sup>	d <sup>+0.1</sup>	L <sup>+0.2</sup>	A <sup>±0.1</sup>	G <sup>-0.05</sup>	M <sup>±0.2</sup>	Tp.
<b>KGD 110 92</b>	110	92	22.5	3.60	106.00	109.0	(a)
<b>KGD 110 95</b>	110	95	20.0	5.00	105.00	108.5	(a)
<b>KGD 110 96</b>	110	96	22.5	5.20	106.00	109.4	(b)
<b>KGD 115 90</b>	115	90	22.4	6.35	108.10	113.0	(a)
<b>KGD 120 95</b>	120	95	22.4	6.35	113.10	118.1	(a)
<b>KGD 120 106</b>	120	106	22.5	5.20	116.00	119.4	(a)
<b>KGD 125 100</b>	125	100	25.4	6.35	118.10	123.0	(a)
<b>KGD 125 100/A</b>	125	100	32.0	10.00	119.00	123.0	(a)
<b>KGD 125 103</b>	125	103	26.5	5.10	121.00	124.0	(a)
<b>KGD 125 105</b>	125	105	25.0	6.35	120.00	123.0	(a)
<b>KGD 125 105/A</b>	125	105	25.4	6.35	119.10	123.3	(a)
<b>KGD 125 108</b>	125	108	26.5	7.20	121.00	124.4	(b)
<b>KGD 130 105</b>	130	105	25.4	9.50	122.60	127.5	(a)
<b>KGD 130 105/A</b>	130	105	25.4	6.35	123.10	128.0	(a)
<b>KGD 135 110</b>	135	110	25.4	9.50	127.60	132.5	(a)
<b>KGD 135 110/A</b>	135	110	25.4	6.35	128.10	133.0	(a)
<b>KGD 140 115</b>	140	115	25.4	9.50	132.60	137.5	(a)
<b>KGD 140 115/A</b>	140	115	25.4	6.35	133.00	138.0	(a)
<b>KGD 140 118</b>	140	118	26.5	5.10	136.00	139.0	(a)
<b>KGD 140 120</b>	140	120	25.0	6.35	135.00	138.0	(a)
<b>KGD 140 123</b>	140	123	26.5	7.20	136.00	139.4	(b)
<b>KGD 145 120</b>	145	120	25.4	9.50	137.60	142.5	(a)
<b>KGD 145 120/A</b>	145	120	25.4	6.35	138.30	142.95	(a)
<b>KGD 150 125</b>	150	125	25.4	9.50	142.60	147.5	(a)

# KGD

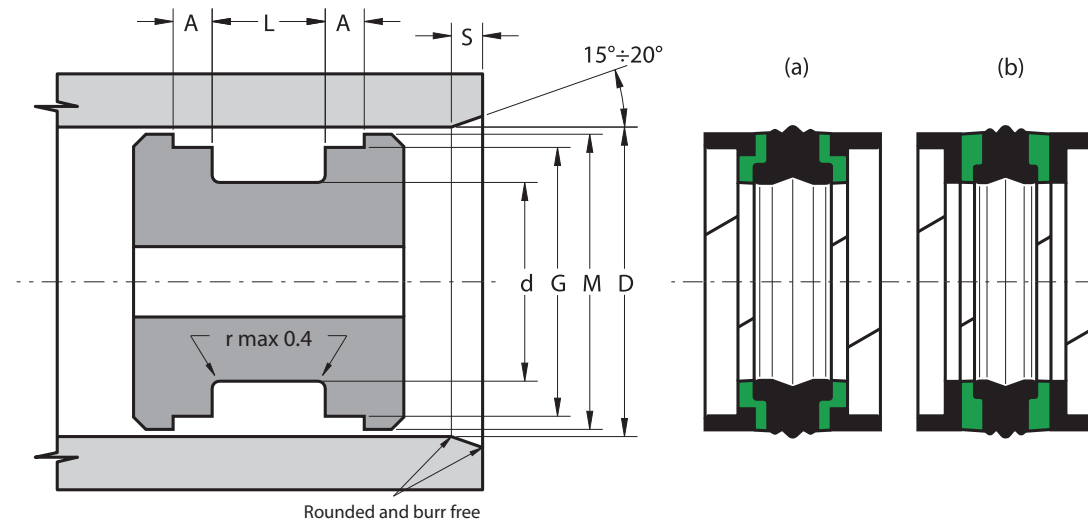

Part.	D <sup>H10</sup>	d <sup>+0.1</sup>	L <sup>+0.2</sup>	A <sup>±0.1</sup>	G <sup>-0.05</sup>	M <sup>±0.2</sup>	Tp.
<b>KGD 150 125/A</b>	150	125	25.4	6.35	143.00	148.0	(a)
<b>KGD 150 128</b>	150	128	25.4	5.10	146.00	149.0	(a)
<b>KGD 150 128/A</b>	150	128	26.5	5.10	146.00	149.0	(a)
<b>KGD 160 130</b>	160	130	25.4	6.35	153.00	157.5	(a)
<b>KGD 160 130/A</b>	160	130	25.4	9.50	152.60	157.5	(a)
<b>KGD 160 135</b>	160	135	25.4	9.50	152.60	157.5	(a)
<b>KGD 160 140</b>	160	140	25.0	6.35	155.00	158.0	(a)
<b>KGD 165 140</b>	165	140	25.4	9.50	157.60	162.5	(a)
<b>KGD 170 145</b>	170	145	25.4	12.70	161.70	167.1	(a)
<b>KGD 175 150</b>	175	150	25.4	12.70	166.70	172.1	(a)
<b>KGD 180 150</b>	180	150	35.4	6.35	172.90	177.9	(a)
<b>KGD 180 155</b>	180	155	25.4	12.70	171.70	177.1	(a)
<b>KGD 185 160</b>	185	160	25.4	12.70	176.70	182.1	(a)

Part.	D <sup>H10</sup>	d <sup>+0.1</sup>	L <sup>+0.2</sup>	A <sup>±0.1</sup>	G <sup>-0.05</sup>	M <sup>±0.2</sup>	Tp.
<b>KGD 190 165</b>	190	165	25.4	12.70	181.70	187.0	(a)
<b>KGD 200 170</b>	200	170	36.0	12.50	192.00	197.0	(a)
<b>KGD 200 170/A</b>	200	170	35.4	6.35	193.00	198.0	(a)
<b>KGD 200 175</b>	200	175	25.4	12.70	191.60	197.0	(a)
<b>KGD 210 185</b>	210	185	25.4	12.70	201.60	207.0	(a)
<b>KGD 220 190</b>	220	190	35.4	6.35	212.70	217.9	(a)
<b>KGD 220 195</b>	220	195	25.4	12.70	211.60	217.0	(a)
<b>KGD 225 200</b>	225	200	25.4	12.70	216.60	222.0	(a)
<b>KGD 230 205</b>	230	205	25.4	12.70	221.60	227.0	(a)
<b>KGD 240 215</b>	240	215	25.4	12.70	231.60	237.0	(a)
<b>KGD 250 220</b>	250	220	35.4	6.35	242.90	247.9	(a)
<b>KGD 250 225</b>	250	225	25.4	12.70	241.60	247.0	(a)

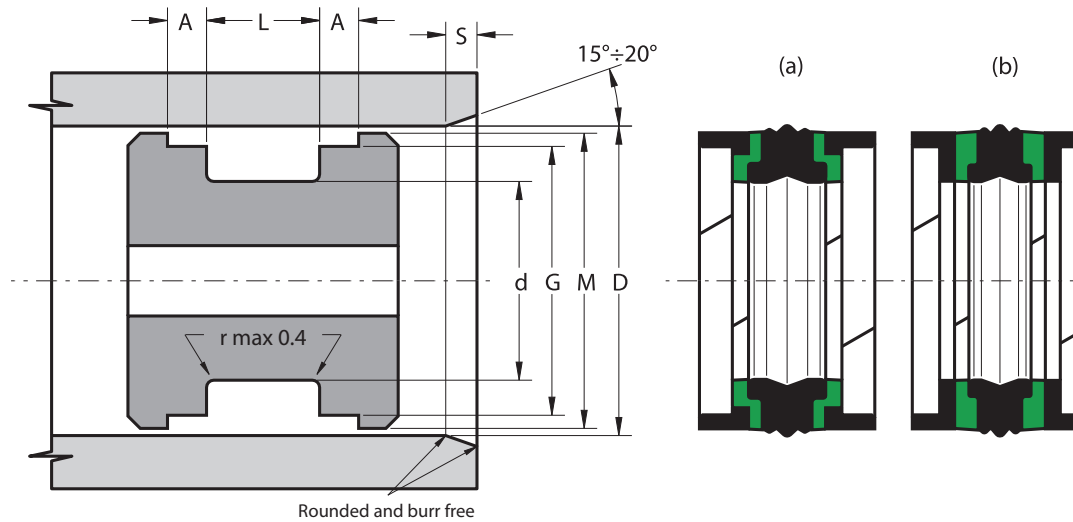

Part.	D <sup>H10</sup>	d <sup>+0.1</sup>	L <sup>+0.2</sup>	A <sup>±0.1</sup>	G <sup>-0.05</sup>	M <sup>±0.2</sup>	Tp.
-------	------------------	-------------------	-------------------	-------------------	--------------------	-------------------	-----

Inch sizes

<b>KGD 1500 1125</b>	38.10	28.57	11.48	6.35	33.55	36.83	(a)
<b>KGD 1500 1125/A</b>	38.10	28.57	11.25	3.81	33.63	36.50	(a)
<b>KGD 1750 1125</b>	44.45	28.57	19.05	6.35	39.87	43.12	(a)
<b>KGD 2000 1375</b>	50.80	34.92	19.05	6.35	46.23	49.48	(a)
<b>KGD 2000 1500</b>	50.80	38.10	14.91	6.35	46.25	49.53	(a)
<b>KGD 2000 1625</b>	50.80	41.27	11.10	3.81	46.27	49.19	(a)
<b>KGD 2375 1750</b>	60.33	44.45	19.05	6.35	55.73	58.98	(a)
<b>KGD 2500 1875</b>	63.50	47.62	19.05	6.35	58.90	62.12	(a)
<b>KGD 2500 2000</b>	63.50	50.80	14.91	6.35	58.95	62.23	(a)
<b>KGD 2500 2125</b>	63.50	53.97	11.10	3.81	59.00	62.12	(a)
<b>KGD 2625 2000</b>	66.67	50.80	19.05	6.35	62.1	65.27	(a)
<b>KGD 3000 2250</b>	76.20	57.15	23.79	6.35	70.40	74.50	(a)
<b>KGD 3000 2500</b>	76.20	63.50	14.91	6.35	70.46	74.68	(a)
<b>KGD 3500 2750</b>	88.90	69.85	23.79	6.35	83.08	87.22	(a)
<b>KGD 3500 3000</b>	88.90	76.20	14.91	6.35	83.13	87.38	(a)
<b>KGD 4000 3250</b>	101.60	82.55	23.79	6.35	95.78	99.92	(a)
<b>KGD 4000 3250/A</b>	101.60	82.55	19.81	6.35	95.78	99.92	(a)
<b>KGD 4500 3750</b>	114.30	95.25	19.81	6.35	107.42	112.78	(a)
<b>KGD 5000 4250</b>	127.00	107.95	19.81	9.53	119.63	124.71	(a)
<b>KGD 6000 5250</b>	152.40	133.35	19.81	9.53	145.03	150.11	(a)
<b>KGD 6000 5250/A</b>	152.40	133.35	19.81	12.70	146.05	150.11	(a)



# KGD/AE

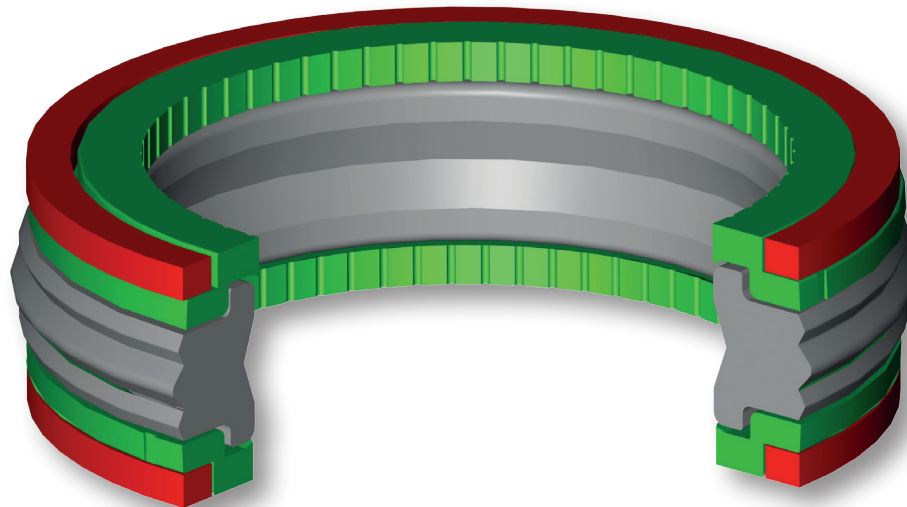

KGD/AE

The piston seal type Aston Seals KGD/AE is composed of:

- A sealing rubber element with low permanent deformation which assures good sealing performance. Three compact and small seal edges ensure perfect fluid control and concentrate load against the dynamic surface. The cavities between the external seal edges keep small quantities of fluid reducing friction and wear. The special geometry of static side guarantees a wide contact area and prevents distortion inside the groove during installation
- Two internal anti-extrusion rings with stabilizers to avoid the rotation of the rubber element. A special geometry of grooves assures that pressure loads the energizing seal

- element without any risk of extrusion of it.
- Two backup rings which offset large gaps or structural deflections without extrusion and assure high longevity
- Good sealing performance as well as at low pressure
- Simple one-part piston design
- High resistance against extrusion
- Perfect fluid control
- Good mechanical stability at high temperature
- Easy installation without expensive auxiliaries
- Good temperature resistance
- Easy installation on a solid piston

## MATERIAL

	① <b>Type</b>	Nitril Rubber NBR
	<b>Designation</b>	RUBSEAL 75
	<b>Hardness</b>	75 °ShA
② <b>Type</b>	Thermoplastic polyester resin	
<b>Designation</b>	SEALITE 63	
<b>Hardness</b>	63 °ShD	
③ <b>Type</b>	Acetal resin	
<b>Designation</b>	BEARITE	

## FIELD OF APPLICATION

<b>Pressure</b> ≤ 400 bar	
<b>Speed</b> ≤ 0.5 m/s	
<b>Temperature</b> -40°C ÷ +110°C	
<b>Fluids</b>	Hydraulic oils (mineral oil based) For other fluids contact our technical department

## SURFACE ROUGHNESS

<b>Dynamic surface</b>	Ra ≤ 0.3 μm	Rt ≤ 2.5 μm
<b>Static surface</b>	Ra ≤ 1.6 μm	Rt ≤ 6.3 μm

## LEAD-IN CHAMFERS

d	Smin
less 100	5 mm
100÷200	7 mm
over 200	10 mm

To avoid damaging the sealing lips during installation, housing must have rounded chamfers. Sharp edges and burrs within the installation area of the seal must be removed.

The above data are maximum values, they may be maintained for short periods and can not be used at the same time simultaneously.



# KGD/AE

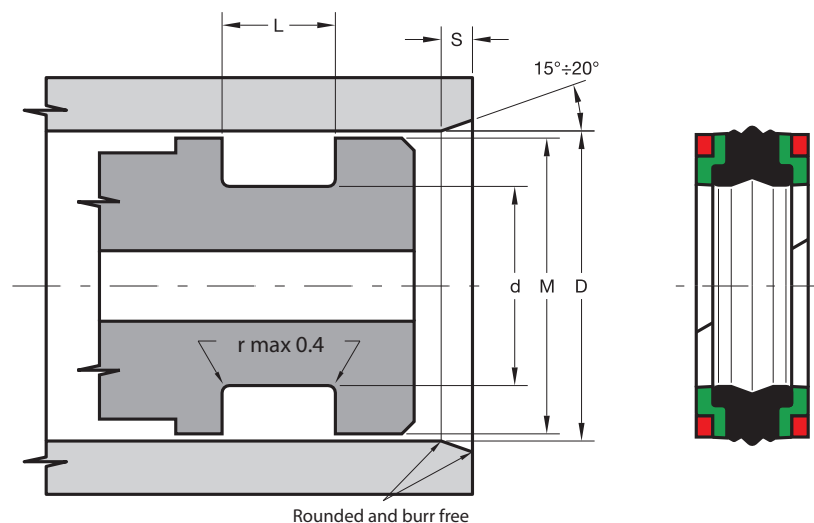

Part.	D <sup>H10</sup>	d <sup>+0.1</sup>	L <sup>+0.2</sup>	M <sup>+0.2</sup>
KGD 20 11/AE	20	11	13.5	19.0
KGD 25 15/AE	25	15	16.4	23.5
KGD 25 15/A/AE	25	15	12.0	23.0
KGD 25 15/B/AE	25	15	12.5	24.0
KGD 25 16/AE	25	16	13.5	24.0
KGD 25 17/AE	25	17	10.0	24.0
KGD 25 17/A/AE	25	17	13.5	24.0
KGD 30 17/AE	30	17	15.4	29.0
KGD 30 21/AE	30	21	13.5	29.0
KGD 32 22/AE	32	22	16.4	30.5
KGD 32 22/A/AE	32	22	15.5	31.0
KGD 32 22/C/AE	32	22	12.5	31.0
KGD 32 24/A/AE	32	24	10.0	31.0
KGD 35 25/AE	35	25	16.4	33.5
KGD 35 25/A/AE	35	25	15.5	34.0
KGD 40 24/AE	40	24	18.4	38.5
KGD 40 26/AE	40	26	15.5	39.0
KGD 40 30/AE	40	30	16.4	38.5
KGD 40 30/A/AE	40	30	12.5	38.0
KGD 40 30/B/AE	40	30	12.5	39.0
KGD 40 32/A/AE	40	32	10.0	39.0
KGD 40 32/AE	40	32	15.5	39.4
KGD 45 29/AE	45	29	18.4	43.7
KGD 45 31/AE	45	31	15.5	44.0

Part.	D <sup>H10</sup>	d <sup>+0.1</sup>	L <sup>+0.2</sup>	M <sup>+0.2</sup>
KGD 45 35/AE	45	35	16.4	43.5
KGD 50 34/AE	50	34	18.4	48.5
KGD 50 34/A/AE	50	34	20.5	49.0
KGD 50 35/AE	50	35	20.0	48.5
KGD 50 38/AE	50	38	20.5	49.4
KGD 50 40/AE	50	40	12.5	49.0
KGD 55 39/AE	55	39	18.4	53.5
KGD 55 39/A/AE	55	39	20.5	54.0
KGD 55 45/AE	55	45	12.5	54.0
KGD 60 44/AE	60	44	18.4	58.5
KGD 60 44/A/AE	60	44	20.5	59.0
KGD 63 47/AE	63	47	18.4	61.5
KGD 63 47/A/AE	63	47	20.5	62.0
KGD 63 47/B/AE	63	47	19.4	61.5
KGD 63 48/AE	63	48	20.0	61.5
KGD 63 51/AE	63	51	20.5	62.4
KGD 63 53/AE	63	53	12.5	62.0
KGD 65 49/AE	65	49	20.5	64.0
KGD 65 50/AE	65	50	18.4	63.5
KGD 70 50/AE	70	50	22.4	68.3
KGD 70 54/AE	70	54	20.5	69.0
KGD 70 55/AE	70	55	20.0	68.5
KGD 70 58/AE	70	58	20.5	69.4
KGD 75 55/AE	75	55	22.4	73.3

Part.	D <sup>H10</sup>	d <sup>+0.1</sup>	L <sup>+0.2</sup>	M <sup>+0.2</sup>
KGD 75 59/AE	75	59	20.5	74.0
KGD 80 60/AE	80	60	22.4	78.3
KGD 80 62/AE	80	62	22.5	79.0
KGD 80 65/AE	80	65	20.0	78.5
KGD 80 66/AE	80	66	22.5	79.4
KGD 85 65/AE	85	65	22.4	83.3
KGD 90 70/AE	90	70	22.4	88.3
KGD 90 72/AE	90	72	22.5	89.0
KGD 90 75/AE	90	75	20.0	88.5
KGD 95 75/AE	95	75	22.4	93.3
KGD 100 75/AE	100	75	22.4	98.0
KGD 100 80/AE	100	80	25.4	98.3
KGD 100 80/D/AE	100	80	25.0	98.0
KGD 100 82/AE	100	82	22.5	99.0
KGD 100 85/AE	100	85	20.0	98.5
KGD 100 86/AE	100	86	22.5	99.4
KGD 105 80/AE	105	80	22.4	103.0
KGD 110 85/AE	110	85	22.4	108.0
KGD 110 85/A/AE	110	85	25.4	108.0
KGD 110 92/AE	110	92	22.5	109.0
KGD 110 95/AE	110	95	20.0	108.5
KGD 115 90/AE	115	90	22.4	113.0
KGD 120 95/AE	120	95	22.4	118.1
KGD 120 106/AE	120	106	22.5	119.4

## KGD/AE

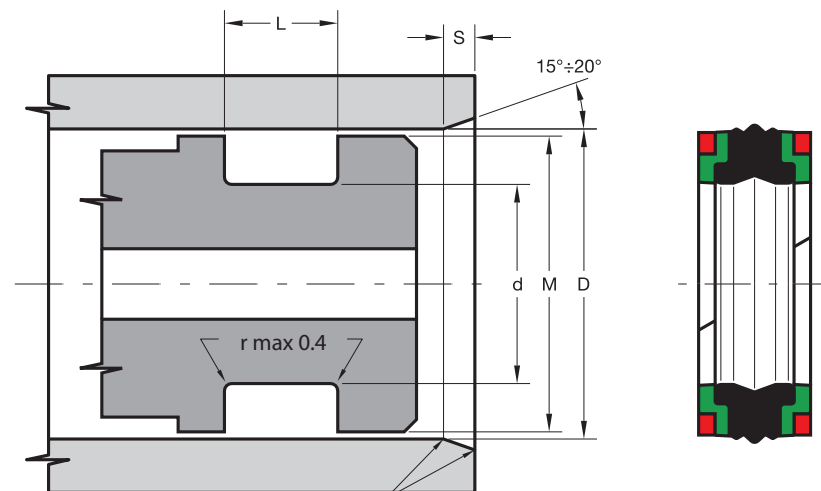

Rounded and burr free

Part.	D <sup>H10</sup>	d <sup>+0.1</sup>	L <sup>+0.2</sup>	M <sup>+0.2</sup>
<b>KGD 125 100/AE</b>	125	100	25.4	123.0
<b>KGD 125 100/A/AE</b>	125	100	32.0	123.0
<b>KGD 125 103/AE</b>	125	103	26.5	124.0
<b>KGD 125 105/AE</b>	125	105	25.0	123.0
<b>KGD 125 105/A/AE</b>	125	105	25.4	123.3
<b>KGD 130 105/AE</b>	130	105	25.4	127.5
<b>KGD 140 115/AE</b>	140	115	25.4	137.5
<b>KGD 150 125/AE</b>	150	125	25.4	147.5
<b>KGD 160 130/AE</b>	160	130	25.4	157.5
<b>KGD 175 150/AE</b>	175	150	25.4	172.1

Inch sizes

<b>KGD 1500 1125/AE</b>	38.10	28.57	11.48	36.83
<b>KGD 2000 1500/AE</b>	50.80	38.10	14.91	49.53
<b>KGD 2500 1875/AE</b>	63.50	47.62	19.05	62.12
<b>KGD 2500 2000/AE</b>	63.50	50.80	14.91	62.23
<b>KGD 3000 2500/AE</b>	76.20	63.50	14.91	74.68
<b>KGD 3500 3000/AE</b>	88.90	76.20	14.91	87.38
<b>KGD 4000 3250/AE</b>	101.60	82.55	23.79	99.92
<b>KGD 4000 3250/A/AE</b>	101.60	82.55	19.81	99.92
<b>KGD 4500 3750/AE</b>	114.30	95.25	19.81	112.78
<b>KGD 5000 4250/AE</b>	127.00	107.95	19.81	124.71
<b>KGD 6000 5250/AE</b>	152.40	133.35	19.81	150.11



# KHT

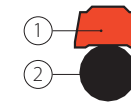

MATERIAL	
① Type	Thermoplastic polyester resin
Designation	SEALITE 55
Hardness	55 °ShD
② Type	Nitril Rubber NBR
Designation	RUBSEAL 70
Hardness	70 °ShA

### FIELD OF APPLICATION

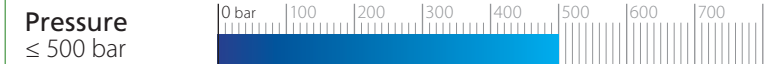

**Fluids**  
Hydraulic oils (mineral oil based)  
For other fluids contact our technical department

### SURFACE ROUGHNESS

<b>Dynamic surface</b>	Ra ≤ 0.3 µm	Rt ≤ 2.5 µm
<b>Static surface</b>	Ra ≤ 1.6 µm	Rt ≤ 6.3 µm

### GAP DIMENSION "g"

The largest gap dimension appearing in operation on the non-pressurised side:

L	100 bar	200 bar	300 bar	400 bar
2.2	0.70	0.45	0.35	0.30
3.2	0.80	0.50	0.40	0.30
4.2	0.80	0.50	0.40	0.35
6.3	0.90	0.55	0.45	0.35
8.1	1.10	0.70	0.50	0.40
> 400 bar ⇒ g <sub>max</sub> = H8/f8				

NB: for the Gap calculation, it is necessary to consider the elastic deformation of metal elements under pressure loads.

To avoid damaging the sealing lips during installation, housing must have rounded chamfers. Sharp edges and burrs within the installation area of the seal must be removed.

The above data are maximum values, they may be maintained for short periods and can not be used at the same time simultaneously.

The piston seal type Aston Seals KHT is composed of:

- A dynamic seal element that, due to the special design, improves the pressure distribution and drastically reduces the friction. It is made of a special high resistance polymer that provides a winning combination for many parts and components: it gives the flexibility of rubbers, the strength of plastics, and the process-ability of thermoplastics. It increases the performance and service life in applications where properties such as abrasion resistance and tear strength are critical. Conical shaped notches allow the seal to energize without risk of extrusion of O-Ring.
- A standard size O-Ring with low permanent deformation as energizing component on

the static side.

- Easy installation on a solid piston
- Returns to the size immediately after assembly
- Low friction and no tendency of stick-slip
- Simple groove design and space-saving construction
- Excellent wear-resistance
- High resistance against extrusion
- Extended service life
- Good temperature resistance

# KHT

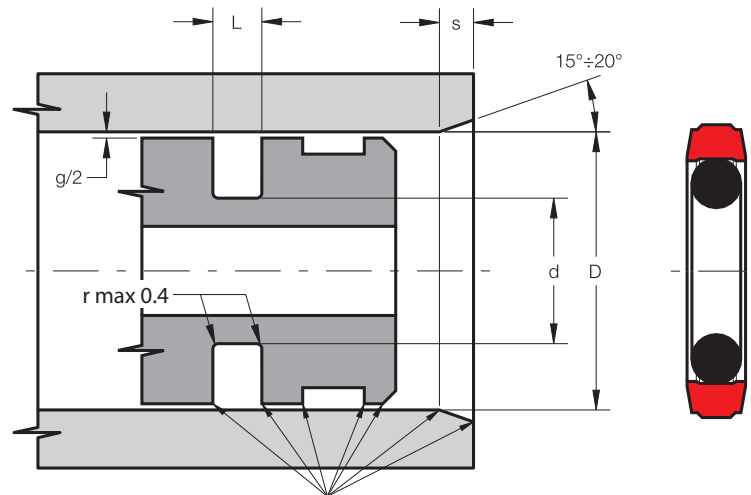

Rounded and burr free

Part.	D <sup>H9</sup>	d <sup>h9</sup>	L <sup>+0.2</sup>	S	OR
<b>KHT 12 7.1 2.2</b>	12	7.1	2.2	2.0	610
<b>KHT 17 12.1 2.2</b>	17	12.1	2.2	2.0	806
<b>KHT 20 12.5 3.2</b>	20	12.5	3.2	2.5	111
<b>KHT 25 17.5 3.2</b>	25	17.5	3.2	2.5	115
<b>KHT 28 20.5 3.2</b>	28	20.5	3.2	2.5	117
<b>KHT 30 22.5 3.2</b>	30	22.5	3.2	2.5	118
<b>KHT 32 24.5 3.2</b>	32	24.5	3.2	2.5	119
<b>KHT 35 27.5 3.2</b>	35	27.5	3.2	2.5	121
<b>KHT 40 29 4.2</b>	40	29.0	4.2	3.5	216
<b>KHT 40 32.5 3.2</b>	40	32.5	3.2	2.5	124
<b>KHT 45 34 4.2</b>	45	34.0	4.2	3.5	219
<b>KHT 48 37 4.2</b>	48	37.0	4.2	3.5	221
<b>KHT 50 34.5 6.3</b>	50	34.5	6.3	5.0	324
<b>KHT 50 39 4.2</b>	50	39.0	4.2	3.5	222

Part.	D <sup>H9</sup>	d <sup>h9</sup>	L <sup>+0.2</sup>	S	OR
<b>KHT 55 44 4.2</b>	55	44.0	4.2	3.5	224
<b>KHT 60 44.5 6.3</b>	60	44.5	6.3	5.0	327
<b>KHT 60 49 4.2</b>	60	49.0	4.2	3.5	225
<b>KHT 63 47.5 6.3</b>	63	47.5	6.3	5.0	328
<b>KHT 63 52 4.2</b>	63	52.0	4.2	3.5	226
<b>KHT 65 49.5 6.3</b>	65	49.5	6.3	5.0	328
<b>KHT 65 52 6.3</b>	65	52.0	6.3	5.0	324
<b>KHT 70 59 4.2</b>	70	59.0	4.2	3.5	228
<b>KHT 75 64 4.2</b>	75	64.0	4.2	3.5	230
<b>KHT 80 64.5 6.3</b>	80	64.5	6.3	5.0	333
<b>KHT 90 74.5 6.3</b>	90	74.5	6.3	5.0	336
<b>KHT 95 79.5 6.3</b>	95	79.5	6.3	5.0	338
<b>KHT 100 84.5 6.3</b>	100	84.5	6.3	5.0	339

# KV

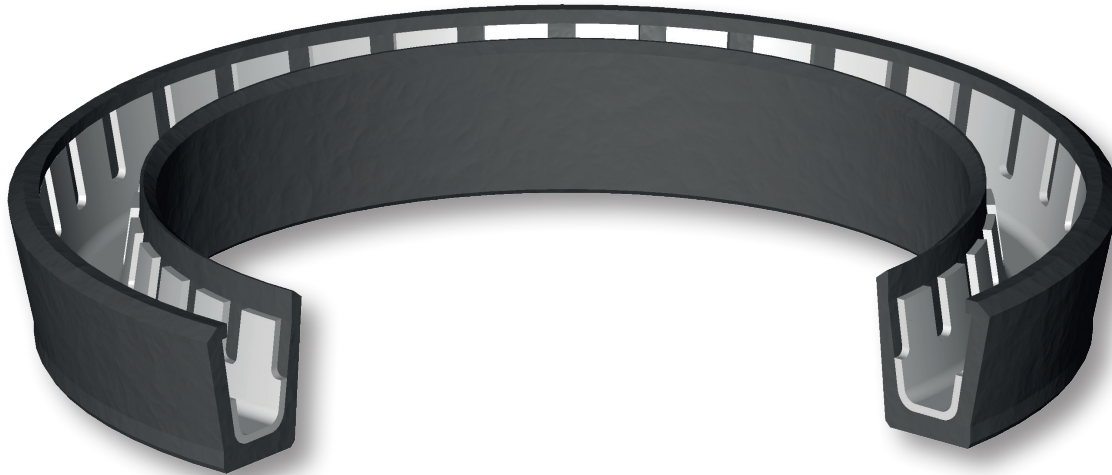

## MATERIAL

- ① **Type Designation** Polytetrafluoroethylene PTFE + carbon  
SEALFLON + Carbon  
⇒ It can be provided with different fillers according to applications
- ② **Type** Stainless 1.4310  
⇒ It can be provided with different materials according to working conditions

## FIELD OF APPLICATION

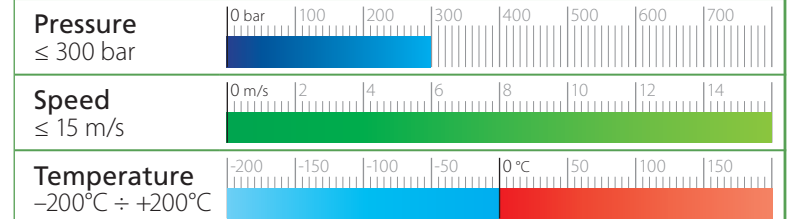

**Fluids** High compatibility with nearly all fluids (which do not attack the PTFE and Stainless)

## SURFACE ROUGHNESS

<b>Dynamic surface</b>	Ra ≤ 0.3 μm	Rt ≤ 2.5 μm
<b>Static surface</b>	Ra ≤ 1.6 μm	Rt ≤ 6.3 μm

## GAP DIMENSION "g"

The largest gap dimension appearing in operation on the non-pressurised side:

L	100 bar	200 bar	300 bar
2.4	0.20	0.16	0.13
3.6	0.30	0.20	0.17
4.8	0.40	0.30	0.22
7.1	0.50	0.40	0.30
9.5	0.60	0.50	0.35

NB: for the Gap calculation, it is necessary to consider the elastic deformation of metal elements under pressure loads.

## LEAD-IN CHAMFERS

L	S	L	S
2.4	2.0	7.1	5.0
3.6	2.5	9.5	6.5
4.8	3.5		

To avoid damaging the sealing lips during installation, housing must have rounded chamfers. Sharp edges and burrs within the installation area of the seal must be removed.

The above data are maximum values, they may be maintained for short periods and can not be used at the same time simultaneously.

The Aston Seals KV is a single acting piston seal energized by a V-shaped metal spring resistant to corrosion.

The asymmetric profile, with appropriately designed dynamic lip, short and heavy, ensures a reduction of friction and a long operating life

The inside metal spring ensures a tight seal even at low pressures.

The possibility of combining different materials for the two components, allows the use of the seal in various areas: hydraulic, chemical, pharmaceutical and food industries.

- High compatibility with nearly all fluids
- Low friction, even in the absence of lubrication

- High speed allowed
- No tendency of stick-slip
- Excellent sealing capability even at low pressure
- Good wear-resistance
- High temperature resistance
- Extended service life

### INSTALLATION

This seal should be mounted preferably in open housing. The snap-in installation is only possible in special designed housing (see figure).

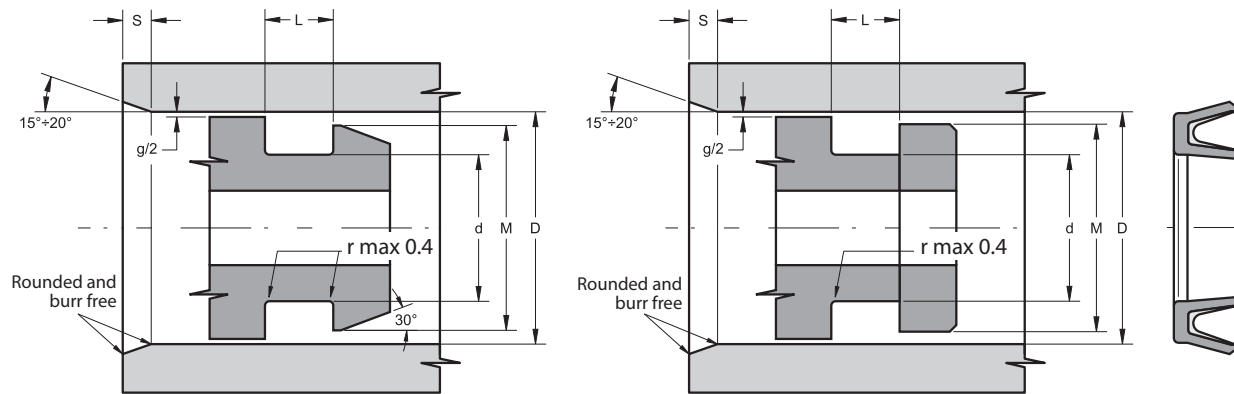

Part.	D <sup>H9</sup>	d <sup>h9</sup>	L <sup>+0.2</sup>	M <sup>min</sup>
<b>KV 8 5.1 2.4</b>	8	5.1	2.4	5.9*
<b>KV 10 7.1 2.4</b>	10	7.1	2.4	7.9*
<b>KV 12 9.1 2.4</b>	12	9.1	2.4	9.9*
<b>KV 14 11.1 2.4</b>	14	11.1	2.4	11.9*
<b>KV 15 10.5 3.6</b>	15	10.5	3.6	11.7
<b>KV 16 11.5 3.6</b>	16	11.5	3.6	12.7
<b>KV 18 13.5 3.6</b>	18	13.5	3.6	14.7
<b>KV 20 15.5 3.6</b>	20	15.5	3.6	16.7
<b>KV 22 17.5 3.6</b>	22	17.5	3.6	18.7
<b>KV 24 19.5 3.6</b>	24	19.5	3.6	20.7
<b>KV 25 20.5 3.6</b>	25	20.5	3.6	21.7
<b>KV 28 21.8 4.8</b>	28	21.8	4.8	23.2
<b>KV 30 23.8 4.8</b>	30	23.8	4.8	25.2
<b>KV 32 25.8 4.8</b>	32	25.8	4.8	27.2
<b>KV 35 28.8 4.8</b>	35	28.8	4.8	30.2
<b>KV 36 29.8 4.8</b>	36	29.8	4.8	31.2
<b>KV 38 31.8 4.8</b>	38	31.8	4.8	33.2
<b>KV 39 32.8 4.8</b>	39	32.8	4.8	34.2
<b>KV 40 33.8 4.8</b>	40	33.8	4.8	35.2
<b>KV 42 35.8 4.8</b>	42	35.8	4.8	37.2
<b>KV 45 38.8 4.8</b>	45	38.8	4.8	40.2
<b>KV 46 39.8 4.8</b>	46	39.8	4.8	41.2

Part.	D <sup>H9</sup>	d <sup>h9</sup>	L <sup>+0.2</sup>	M <sup>min</sup>
<b>KV 48 38.6 7.1</b>	48	38.6	7.1	40.2
<b>KV 50 40.6 7.1</b>	50	40.6	7.1	42.2
<b>KV 52 42.6 7.1</b>	52	42.6	7.1	44.2
<b>KV 55 45.6 7.1</b>	55	45.6	7.1	47.2
<b>KV 57 47.6 7.1</b>	57	47.6	7.1	49.2
<b>KV 60 50.6 7.1</b>	60	50.6	7.1	52.2
<b>KV 63 53.6 7.1</b>	63	53.6	7.1	55.2
<b>KV 64 54.6 7.1</b>	64	54.6	7.1	56.2
<b>KV 65 55.6 7.1</b>	65	55.6	7.1	57.2
<b>KV 70 60.6 7.1</b>	70	60.6	7.1	62.2
<b>KV 75 65.6 7.1</b>	75	65.6	7.1	67.2
<b>KV 80 70.6 7.1</b>	80	70.6	7.1	72.2
<b>KV 85 75.6 7.1</b>	85	75.6	7.1	77.2
<b>KV 89 79.6 7.1</b>	89	79.6	7.1	81.2
<b>KV 90 80.6 7.1</b>	90	80.6	7.1	82.2
<b>KV 95 85.6 7.1</b>	95	85.6	7.1	87.2
<b>KV 100 90.6 7.1</b>	100	90.6	7.1	92.2
<b>KV 105 95.6 7.1</b>	105	95.6	7.1	97.2
<b>KV 110 100.6 7.1</b>	110	100.6	7.1	102.2
<b>KV 115 105.6 7.1</b>	115	105.6	7.1	107.2
<b>KV 120 110.6 7.1</b>	120	110.6	7.1	112.2
<b>KV 125 115.6 7.1</b>	125	115.6	7.1	117.2

Part.	D <sup>H9</sup>	d <sup>h9</sup>	L <sup>+0.2</sup>	M <sup>min</sup>
<b>KV 130 117.8 9.5</b>	130	117.8	9.5	119.6
<b>KV 132 119.8 9.5</b>	132	119.8	9.5	121.6
<b>KV 133 120.8 9.5</b>	133	120.8	9.5	122.6
<b>KV 135 122.8 9.5</b>	135	122.8	9.5	124.6
<b>KV 140 127.8 9.5</b>	140	127.8	9.5	129.6
<b>KV 145 132.8 9.5</b>	145	132.8	9.5	134.6
<b>KV 150 137.8 9.5</b>	150	137.8	9.5	139.6
<b>KV 154 141.8 9.5</b>	154	141.8	9.5	143.6
<b>KV 155 142.8 9.5</b>	155	142.8	9.5	144.6
<b>KV 160 147.8 9.5</b>	160	147.8	9.5	149.6
<b>KV 165 152.8 9.5</b>	165	152.8	9.5	154.6
<b>KV 170 157.8 9.5</b>	170	157.8	9.5	159.6
<b>KV 175 162.8 9.5</b>	175	162.8	9.5	164.6
<b>KV 180 167.8 9.5</b>	180	167.8	9.5	169.6
<b>KV 185 172.8 9.5</b>	185	172.8	9.5	174.6
<b>KV 190 177.8 9.5</b>	190	177.8	9.5	179.6
<b>KV 200 187.8 9.5</b>	200	187.8	9.5	189.6
<b>KV 210 197.8 9.5</b>	210	197.8	9.5	199.6
<b>KV 220 207.8 9.5</b>	220	207.8	9.5	209.6
<b>KV 230 217.8 9.5</b>	230	217.8	9.5	219.6
<b>KV 240 227.8 9.5</b>	240	227.8	9.5	229.6
<b>KV 250 237.8 9.5</b>	250	237.8	9.5	239.6

\* Open groove assembly

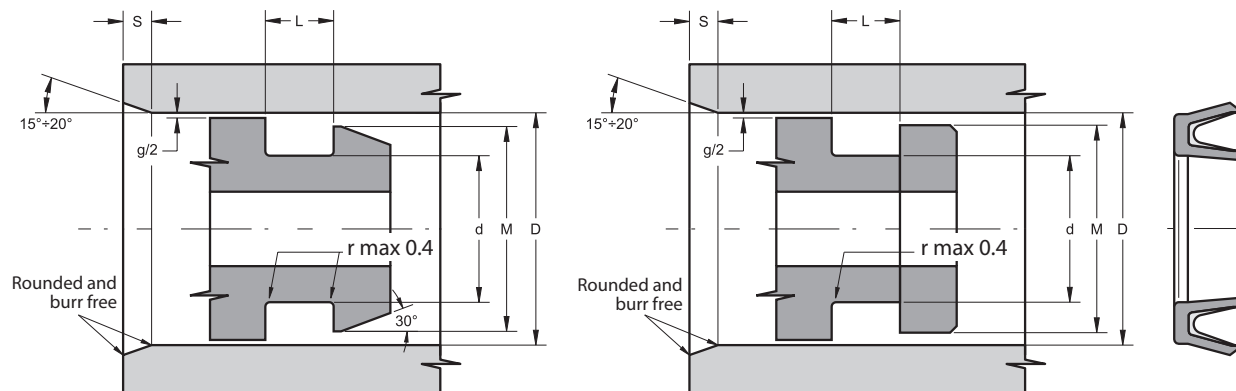

Part.	D <sup>H9</sup>	d <sup>h9</sup>	L <sup>+0.2</sup>	M <sup>min</sup>
<b>KV 260 247.8 9.5</b>	260	247.8	9.5	249.6
<b>KV 270 257.8 9.5</b>	270	257.8	9.5	259.6
<b>KV 280 267.8 9.5</b>	280	267.8	9.5	269.6
<b>KV 290 277.8 9.5</b>	290	277.8	9.5	279.6
<b>KV 300 287.8 9.5</b>	300	287.8	9.5	289.6
<b>KV 310 297.8 9.5</b>	310	297.8	9.5	299.6
<b>KV 320 307.8 9.5</b>	320	307.8	9.5	309.6
<b>KV 330 317.8 9.5</b>	330	317.8	9.5	319.6
<b>KV 340 327.8 9.5</b>	340	327.8	9.5	329.6
<b>KV 350 337.8 9.5</b>	350	337.8	9.5	339.6
<b>KV 360 347.8 9.5</b>	360	347.8	9.5	349.6
<b>KV 370 357.8 9.5</b>	370	357.8	9.5	359.6
<b>KV 380 367.8 9.5</b>	380	367.8	9.5	369.6

Part.	D <sup>H9</sup>	d <sup>h9</sup>	L <sup>+0.2</sup>	M <sup>min</sup>
<b>KV 390 377.8 9.5</b>	390	377.8	9.5	379.6
<b>KV 400 387.8 9.5</b>	400	387.8	9.5	389.6
<b>KV 410 397.8 9.5</b>	410	397.8	9.5	399.6
<b>KV 420 407.8 9.5</b>	420	407.8	9.5	409.6
<b>KV 430 417.8 9.5</b>	430	417.8	9.5	419.6
<b>KV 440 427.8 9.5</b>	440	427.8	9.5	429.6
<b>KV 450 437.8 9.5</b>	450	437.8	9.5	439.6
<b>KV 460 447.8 9.5</b>	460	447.8	9.5	449.6
<b>KV 470 457.8 9.5</b>	470	457.8	9.5	459.6
<b>KV 480 467.8 9.5</b>	480	467.8	9.5	469.6
<b>KV 490 477.8 9.5</b>	490	477.8	9.5	479.6
<b>KV 500 487.8 9.5</b>	500	487.8	9.5	489.6

Other sizes not present in the above table can be provided in according to the following scheme:

D <sup>H9</sup>	d <sup>h9</sup>	L <sup>+0.2</sup>	M <sup>min</sup>
8-14	D - 2.9	2.4*	D - 2.1
>14-25	D - 4.5	3.6	D - 3.3
>25-46	D - 6.2	4.8	D - 4.8
>46-125	D - 9.4	7.1	D - 7.8
>125-500	D - 12.2	9.5	D - 10.4

\* Open groove assembly





# YB

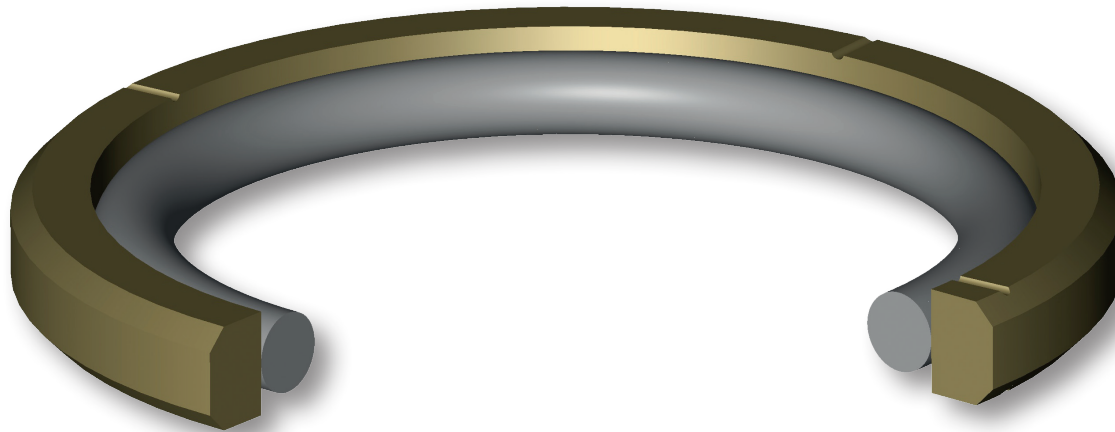

## MATERIAL

- ① **Type** Polytetrafluoroethylene PTFE + Bronze  
**Designation** SEALFLON + Bronze  
 ⇒ It can be provided with different fillers according to applications
- ② **Type** Nitril Rubber NBR  
**Designation** RUBSEAL 70  
**Hardness** 70 °ShA  
 ⇒ It can be provided with different materials according to working conditions

## FIELD OF APPLICATION

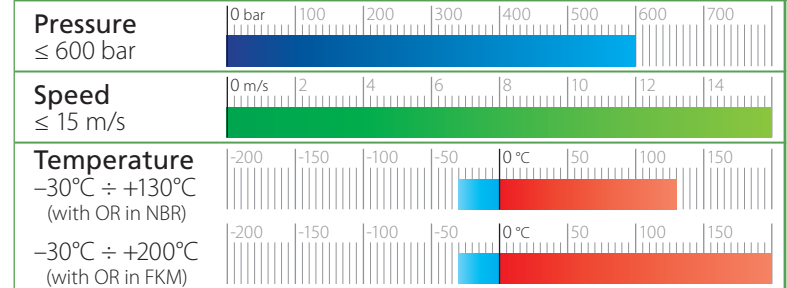

**Fluids** High compatibility with nearly all fluids (with the right choice of O-Ring material)

## SURFACE ROUGHNESS

<b>Dynamic surface</b>	Ra ≤ 0.3 μm	Rt ≤ 2.5 μm
<b>Static surface</b>	Ra ≤ 1.6 μm	Rt ≤ 6.3 μm

## GAP DIMENSION "g"

The largest gap dimension [mm] appearing in operation on the non-pressurised side:

L	100 bar	200 bar	400 bar
2.2	0.60	0.40	0.30
3.2	0.80	0.50	0.30
4.2	0.80	0.50	0.40
6.3	1.00	0.60	0.40
8.1	1.20	0.70	0.50
9.5	1.40	1.00	0.60
13.8	2.00	1.40	1.20
> 400 bar ⇒ $g_{max} = H8/f8$			

NB: for the Gap calculation, it is necessary to consider the elastic deformation of metal elements under pressure loads.

To avoid damaging the sealing lips during installation, housing must have rounded chamfers. Sharp edges and burrs within the installation area of the seal must be removed.

The above data are maximum values, they may be maintained for short periods and can not be used at the same time simultaneously.

The piston seal type Aston Seals YB is composed of:

- A dynamic seal element which assures exceptional low friction and high speed performance, high compatibility with nearly all media due to the chemical resistance which exceeds that of all other thermoplastics and elastomers. Side grooves ensure that pressure loads the energizing O-Ring in all work conditions
- A standard size O-Ring with low permanent deformation as energizing component on the static side
- Low static and dynamic friction
- High speed allowed

- No tendency of stick-slip
- Space-saving construction and simple groove design
- High compatibility with nearly all fluids (with the right choice of O-Ring material)
- High resistance against extrusion
- High temperature resistance

YB

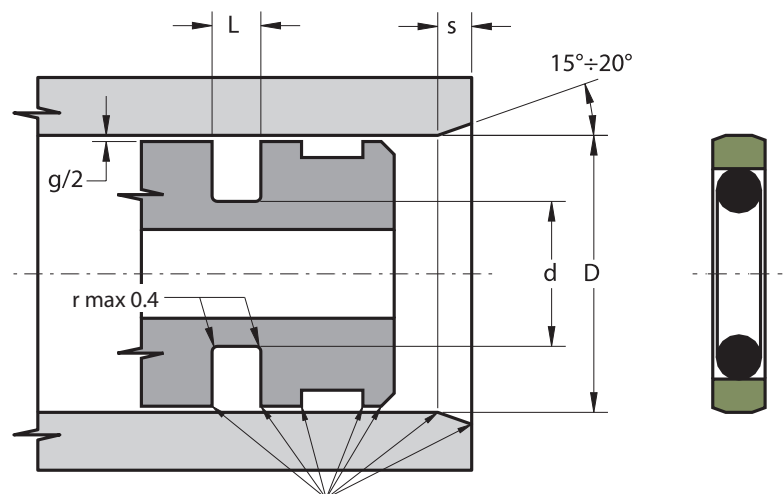

Rounded and burr free

Part.	D <sup>H9</sup>	d <sup>h9</sup>	L <sup>+0.2</sup>	S	OR
YB 8 3.1 2.2	8	3.1	2.2	2.0	006
YB 10 5.1 2.2	10	5.1	2.2	2.0	009
YB 12 7.1 2.2	12	7.1	2.2	2.0	610
YB 15 7.5 3.2	15	7.5	3.2	2.5	109
YB 16 8.5 3.2	16	8.5	3.2	2.5	109
YB 18 10.5 3.2	18	10.5	3.2	2.5	110
YB 20 12.5 3.2	20	12.5	3.2	2.5	111
YB 22 14.5 3.2	22	14.5	3.2	2.5	113
YB 24 16.5 3.2	24	16.5	3.2	2.5	809
YB 25 17.5 3.2	25	17.5	3.2	2.5	115
YB 28 20.5 3.2	28	20.5	3.2	2.5	117
YB 30 22.5 3.2	30	22.5	3.2	2.5	118
YB 32 24.5 3.2	32	24.5	3.2	2.5	119
YB 35 27.5 3.2	35	27.5	3.2	2.5	121
YB 36 28.5 3.2	36	28.5	3.2	2.5	122
YB 38 30.5 3.2	38	30.5	3.2	2.5	123
YB 39 31.5 3.2	39	31.5	3.2	2.5	124
YB 40 29 4.2	40	29.0	4.2	3.5	216
YB 42 31 4.2	42	31.0	4.2	3.5	217
YB 45 34 4.2	45	34.0	4.2	3.5	219
YB 48 37 4.2	48	37.0	4.2	3.5	221
YB 50 39 4.2	50	39.0	4.2	3.5	222
YB 52 41 4.2	52	41.0	4.2	3.5	223
YB 55 44 4.2	55	44.0	4.2	3.5	224

Part.	D <sup>H9</sup>	d <sup>h9</sup>	L <sup>+0.2</sup>	S	OR
YB 57 46 4.2	57	46.0	4.2	3.5	827
YB 60 49 4.2	60	49.0	4.2	3.5	225
YB 62 51 4.2	62	51.0	4.2	3.5	226
YB 63 52 4.2	63	52.0	4.2	3.5	226
YB 64 53 4.2	64	53.0	4.2	3.5	226
YB 65 54 4.2	65	54.0	4.2	3.5	227
YB 70 59 4.2	70	59.0	4.2	3.5	228
YB 75 64 4.2	75	64.0	4.2	3.5	230
YB 80 64.5 6.3	80	64.5	6.3	5.0	333
YB 85 69.5 6.3	85	69.5	6.3	5.0	335
YB 89 73.5 6.3	89	73.5	6.3	5.0	336
YB 90 74.5 6.3	90	74.5	6.3	5.0	336
YB 95 79.5 6.3	95	79.5	6.3	5.0	338
YB 100 84.5 6.3	100	84.5	6.3	5.0	339
YB 105 89.5 6.3	105	89.5	6.3	5.0	341
YB 110 94.5 6.3	110	94.5	6.3	5.0	343
YB 115 99.5 6.3	115	99.5	6.3	5.0	344
YB 120 104.5 6.3	120	104.5	6.3	5.0	346
YB 125 109.5 6.3	125	109.5	6.3	5.0	347
YB 130 114.5 6.3	130	114.5	6.3	5.0	349
YB 132 116.5 6.3	132	116.5	6.3	5.0	350
YB 133 112 8.1	133	112.0	8.1	6.5	425
YB 135 114 8.1	135	114.0	8.1	6.5	425
YB 140 119 8.1	140	119.0	8.1	6.5	426

Part.	D <sup>H9</sup>	d <sup>h9</sup>	L <sup>+0.2</sup>	S	OR
YB 145 124 8.1	145	124.0	8.1	6.5	428
YB 150 129 8.1	150	129.0	8.1	6.5	429
YB 154 133 8.1	154	133.0	8.1	6.5	431
YB 155 134 8.1	155	134.0	8.1	6.5	431
YB 160 139 8.1	160	139.0	8.1	6.5	433
YB 165 144 8.1	165	144.0	8.1	6.5	434
YB 170 149 8.1	170	149.0	8.1	6.5	436
YB 175 154 8.1	175	154.0	8.1	6.5	437
YB 180 159 8.1	180	159.0	8.1	6.5	438
YB 185 164 8.1	185	164.0	8.1	6.5	874
YB 190 169 8.1	190	169.0	8.1	6.5	439
YB 200 179 8.1	200	179.0	8.1	6.5	441
YB 210 189 8.1	210	189.0	8.1	6.5	882
YB 220 199 8.1	220	199.0	8.1	6.5	444
YB 230 209 8.1	230	209.0	8.1	6.5	445
YB 240 219 8.1	240	219.0	8.1	6.5	446
YB 250 229 8.1	250	229.0	8.1	6.5	447
YB 260 239 8.1	260	239.0	8.1	6.5	447
YB 270 249 8.1	270	249.0	8.1	6.5	680
YB 280 259 8.1	280	259.0	8.1	6.5	449
YB 290 269 8.1	290	269.0	8.1	6.5	450
YB 300 279 8.1	300	279.0	8.1	6.5	451
YB 310 289 8.1	310	289.0	8.1	6.5	451
YB 320 299 8.1	320	299.0	8.1	6.5	452

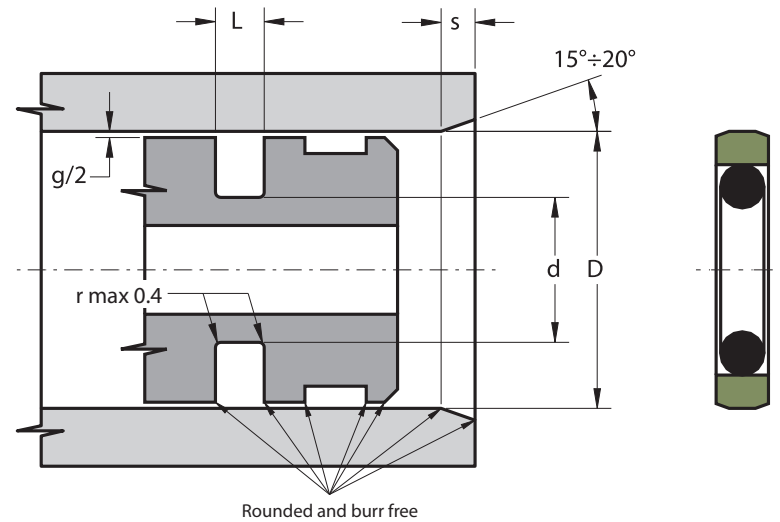

Part.	D <sup>H9</sup>	d <sup>h9</sup>	L <sup>+0.2</sup>	S	OR
YB 330 305.5 8.1	330	305.5	8.1	6.5	453
YB 340 315.5 8.1	340	315.5	8.1	6.5	453
YB 350 325.5 8.1	350	325.5	8.1	6.5	454
YB 360 335.5 8.1	360	335.5	8.1	6.5	455
YB 370 345.5 8.1	370	345.5	8.1	6.5	456
YB 380 355.5 8.1	380	355.5	8.1	6.5	457
YB 390 365.5 8.1	390	365.5	8.1	6.5	457
YB 400 375.5 8.1	400	375.5	8.1	6.5	458
YB 410 385.5 8.1	410	385.5	8.1	6.5	459
YB 420 395.5 8.1	420	395.5	8.1	6.5	460
YB 430 405.5 8.1	430	405.5	8.1	6.5	461
YB 440 415.5 8.1	440	415.5	8.1	6.5	461
YB 450 425.5 8.1	450	425.5	8.1	6.5	462
YB 460 435.5 8.1	460	435.5	8.1	6.5	463
YB 470 445.5 8.1	470	445.5	8.1	6.5	464
YB 480 455.5 8.1	480	455.5	8.1	6.5	464
YB 490 465.5 8.1	490	465.5	8.1	6.5	465
YB 500 475.5 8.1	500	475.5	8.1	6.5	466

Other sizes not present in the above table can be provided in according to the following scheme:

D			d	L	S	S. OR
Light series	Standard series	Heavy series				
15 ÷ 39.9	<b>8 ÷ 14.9</b>		D - 4.9	2.2	2.0	1.78
40 ÷ 79.9	<b>15 ÷ 39.9</b>		D - 7.5	3.2	2.5	2.62
80 ÷ 132.9	<b>40 ÷ 79.9</b>	15 ÷ 39.9	D - 11.0	4.2	3.5	3.53
133 ÷ 329.9	<b>80 ÷ 132.9</b>	40 ÷ 79.9	D - 15.5	6.3	5.0	5.34
330 ÷ 669.9	<b>133 ÷ 329.9</b>	80 ÷ 132.9	D - 21.0	8.1	6.5	6.99
670 ÷ 999.9	<b>330 ÷ 669.9</b>	133 ÷ 329.9	D - 24.5	8.1	6.5	6.99
	<b>670 ÷ 999.9</b>	330 ÷ 669.9	D - 28.0	9.5	7.5	8.40
	<b>&gt; 1000</b>		D - 38.0	13.8	10.0	12.0



# YAB

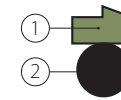
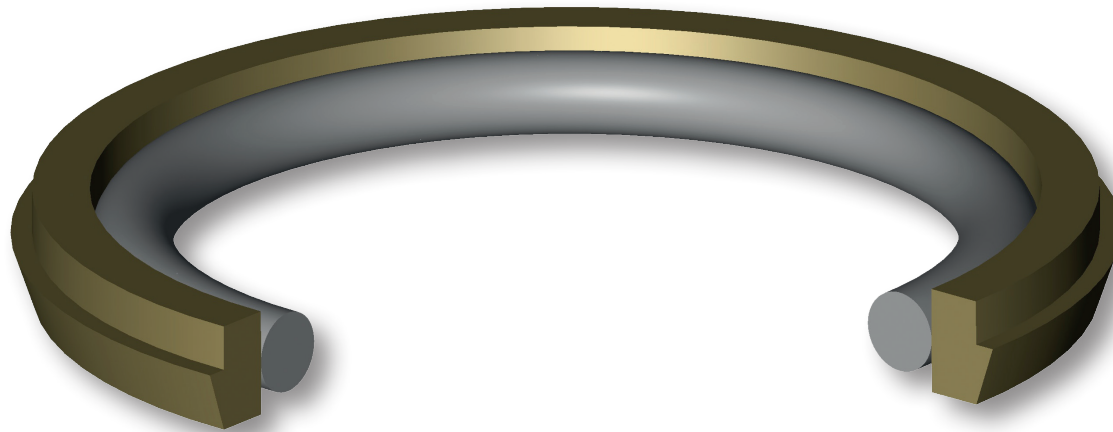

- ① **Type** Polytetrafluoroethylene PTFE + Bronze  
**Designation** SEALFLON + Bronze  
 ⇒ It can be provided with different fillers according to applications
- ② **Type** Nitril Rubber NBR  
**Designation** RUBSEAL 70  
**Hardness** 70 °ShA  
 ⇒ It can be provided with different materials according to working conditions

### FIELD OF APPLICATION

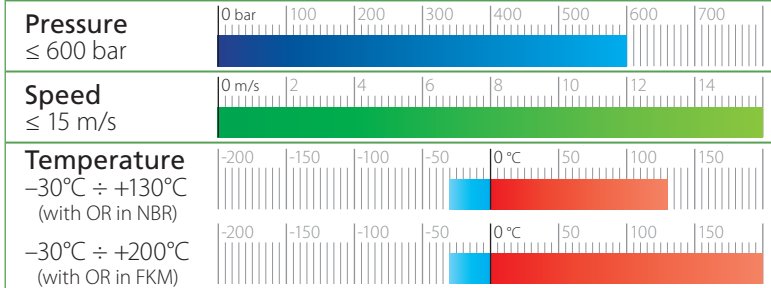

**Fluids** High compatibility with nearly all fluids (with the right choice of O-Ring material)

### SURFACE ROUGHNESS

<b>Dynamic surface</b>	Ra ≤ 0.3 μm	Rt ≤ 2.5 μm
<b>Static surface</b>	Ra ≤ 1.6 μm	Rt ≤ 6.3 μm

### GAP DIMENSION "g"

The largest gap dimension [mm] appearing in operation on the non-pressurised side:

L	100 bar	200 bar	400 bar
2.2	0.60	0.40	0.30
3.2	0.80	0.50	0.30
4.2	0.80	0.50	0.40
6.3	1.00	0.60	0.40
8.1	1.20	0.70	0.50
9.5	1.40	1.00	0.60
13.8	2.00	1.40	1.20

> 400 bar ⇒  $g_{max} = H8/f8$

NB: for the Gap calculation, it is necessary to consider the elastic deformation of metal elements under pressure loads.

To avoid damaging the sealing lips during installation, housing must have rounded chamfers. Sharp edges and burrs within the installation area of the seal must be removed.

The above data are maximum values, they may be maintained for short periods and can not be used at the same time simultaneously.

The piston seal type Aston Seals YAB is composed of:

- A dynamic seal element which assures exceptional low friction and high speed performance, high compatibility with nearly all media due to the chemical resistance which exceeds that of all other thermoplastics and elastomers.
- A standard size O-Ring with low permanent deformation as energizing component on the static side
- Low static and dynamic friction
- High speed allowed
- No tendency of stick-slip
- Space-saving construction and simple groove

design

- High compatibility with nearly all fluids (with the right choice of O-Ring material)
- High resistance against extrusion
- High temperature resistance

# YAB

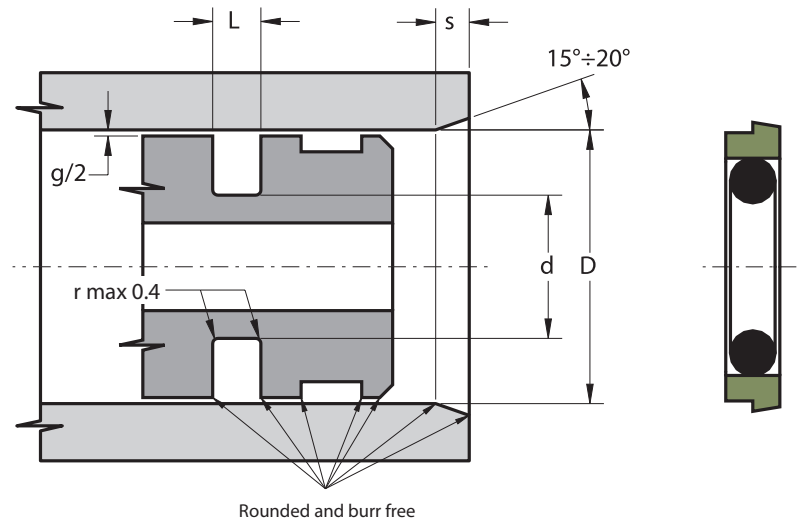

Part.	D <sup>H9</sup>	d <sup>h9</sup>	L <sup>+0.2</sup>	S	OR
YAB 8 3.1 2.2	8	3.1	2.2	2.0	006
YAB 10 5.1 2.2	10	5.1	2.2	2.0	009
YAB 12 7.1 2.2	12	7.1	2.2	2.0	610
YAB 15 10.1 2.2	15	10.1	2.2	2.0	012
YAB 16 11.1 2.2	16	11.1	2.2	2.0	013
YAB 18 10.7 3.2	18	10.7	3.2	2.5	111
YAB 20 12.7 3.2	20	12.7	3.2	2.5	112
YAB 22 14.7 3.2	22	14.7	3.2	2.5	113
YAB 24 16.7 3.2	24	16.7	3.2	2.5	809
YAB 25 17.7 3.2	25	17.7	3.2	2.5	115
YAB 28 17.3 4.2	28	17.3	4.2	3.5	209
YAB 30 19.3 4.2	30	19.3	4.2	3.5	210
YAB 32 21.3 4.2	32	21.3	4.2	3.5	211
YAB 35 24.3 4.2	35	24.3	4.2	3.5	213
YAB 36 25.3 4.2	36	25.3	4.2	3.5	214
YAB 38 27.3 4.2	38	27.3	4.2	3.5	215
YAB 39 28.3 4.2	39	28.3	4.2	3.5	215
YAB 40 29.3 4.2	40	29.3	4.2	3.5	216
YAB 42 31.3 4.2	42	31.3	4.2	3.5	217
YAB 45 34.3 4.2	45	34.3	4.2	3.5	219
YAB 48 37.3 4.2	48	37.3	4.2	3.5	221
YAB 50 39.3 4.2	50	39.3	4.2	3.5	222
YAB 52 41.3 4.2	52	41.3	4.2	3.5	223
YAB 55 44.3 4.2	55	44.3	4.2	3.5	224

Part.	D <sup>H9</sup>	d <sup>h9</sup>	L <sup>+0.2</sup>	S	OR
YAB 57 46.3 4.2	57	46.3	4.2	3.5	828
YAB 60 44.9 6.3	60	44.9	6.3	5.0	327
YAB 63 47.9 6.3	63	47.9	6.3	5.0	328
YAB 64 48.9 6.3	64	48.9	6.3	5.0	328
YAB 65 49.9 6.3	65	49.9	6.3	5.0	328
YAB 70 54.9 6.3	70	54.9	6.3	5.0	330
YAB 75 59.9 6.3	75	59.9	6.3	5.0	332
YAB 80 64.9 6.3	80	64.9	6.3	5.0	333
YAB 85 69.9 6.3	85	69.9	6.3	5.0	335
YAB 89 73.9 6.3	89	73.9	6.3	5.0	336
YAB 90 74.9 6.3	90	74.9	6.3	5.0	336
YAB 95 79.9 6.3	95	79.9	6.3	5.0	337
YAB 100 84.9 6.3	100	84.9	6.3	5.0	340
YAB 105 89.9 6.3	105	89.9	6.3	5.0	341
YAB 110 94.9 6.3	110	94.9	6.3	5.0	343
YAB 115 99.9 6.3	115	99.9	6.3	5.0	344
YAB 120 104.9 6.3	120	104.9	6.3	5.0	346
YAB 125 109.9 6.3	125	109.9	6.3	5.0	347
YAB 130 114.9 6.3	130	114.9	6.3	5.0	349
YAB 132 116.9 6.3	132	116.9	6.3	5.0	349
YAB 133 117.9 6.3	133	117.9	6.3	5.0	350
YAB 135 119.9 6.3	135	119.9	6.3	5.0	351
YAB 140 124.9 6.3	140	124.9	6.3	5.0	352
YAB 145 129.9 6.3	145	129.9	6.3	5.0	353

Part.	D <sup>H9</sup>	d <sup>h9</sup>	L <sup>+0.2</sup>	S	OR
YAB 150 134.9 6.3	150	134.9	6.3	5.0	355
YAB 154 138.9 6.3	154	138.9	6.3	5.0	356
YAB 155 139.9 6.3	155	139.9	6.3	5.0	356
YAB 160 144.9 6.3	160	144.9	6.3	5.0	358
YAB 165 149.9 6.3	165	149.9	6.3	5.0	360
YAB 170 154.9 6.3	170	154.9	6.3	5.0	361
YAB 175 159.9 6.3	175	159.9	6.3	5.0	362
YAB 180 164.9 6.3	180	164.9	6.3	5.0	363
YAB 185 169.9 6.3	185	169.9	6.3	5.0	363
YAB 190 174.9 6.3	190	174.9	6.3	5.0	364
YAB 200 179.5 8.1	200	179.5	8.1	6.5	441
YAB 210 189.5 8.1	210	189.5	8.1	6.5	882
YAB 220 199.5 8.1	220	199.5	8.1	6.5	444
YAB 230 209.5 8.1	230	209.5	8.1	6.5	445
YAB 240 219.5 8.1	240	219.5	8.1	6.5	446
YAB 250 229.5 8.1	250	229.5	8.1	6.5	447
YAB 260 236 8.1	260	236.0	8.1	6.5	447
YAB 270 246 8.1	270	246.0	8.1	6.5	448
YAB 280 256 8.1	280	256.0	8.1	6.5	449
YAB 290 266 8.1	290	266.0	8.1	6.5	449
YAB 300 276 8.1	300	276.0	8.1	6.5	451
YAB 310 286 8.1	310	286.0	8.1	6.5	451
YAB 320 296 8.1	320	296.0	8.1	6.5	452
YAB 330 306 8.1	330	306.0	8.1	6.5	453

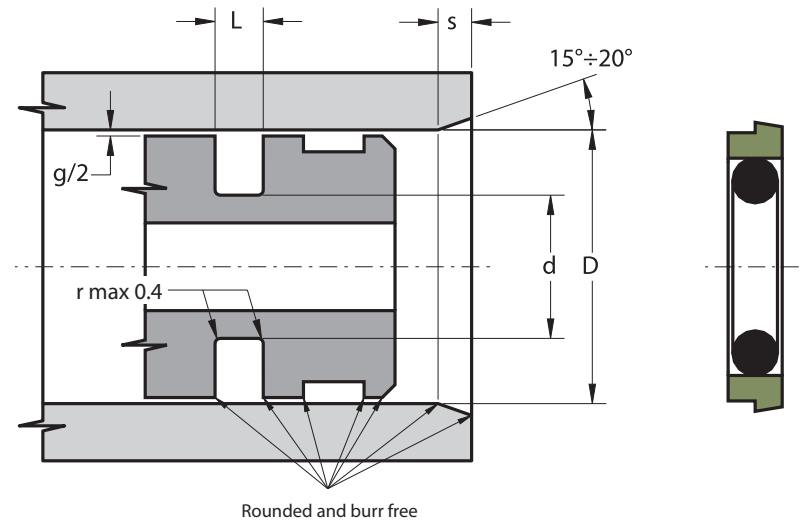

Part.	D <sup>H9</sup>	d <sup>h9</sup>	L <sup>+0.2</sup>	S	OR
<b>YAB 340 316 8.1</b>	340	316.0	8.1	6.5	453
<b>YAB 350 326 8.1</b>	350	326.0	8.1	6.5	454
<b>YAB 360 336 8.1</b>	360	336.0	8.1	6.5	455
<b>YAB 370 346 8.1</b>	370	346.0	8.1	6.5	456
<b>YAB 380 356 8.1</b>	380	356.0	8.1	6.5	457
<b>YAB 390 366 8.1</b>	390	366.0	8.1	6.5	457
<b>YAB 400 376 8.1</b>	400	376.0	8.1	6.5	458
<b>YAB 410 386 8.1</b>	410	386.0	8.1	6.5	459
<b>YAB 420 396 8.1</b>	420	396.0	8.1	6.5	460
<b>YAB 430 406 8.1</b>	430	406.0	8.1	6.5	461
<b>YAB 440 416 8.1</b>	440	416.0	8.1	6.5	461
<b>YAB 450 426 8.1</b>	450	426.0	8.1	6.5	462
<b>YAB 460 436 8.1</b>	460	436.0	8.1	6.5	463
<b>YAB 470 446 8.1</b>	470	446.0	8.1	6.5	464
<b>YAB 480 456 8.1</b>	480	456.0	8.1	6.5	464
<b>YAB 490 466 8.1</b>	490	466.0	8.1	6.5	465
<b>YAB 500 476 8.1</b>	500	476.0	8.1	6.5	466

Other sizes not present in the above table can be provided in according to the following scheme:

D			d	L	S	S. OR
Light series	Standard series	Heavy series				
17 ÷ 26.9	<b>8 ÷ 16.9</b>		D - 4.9	2.2	2.0	1.78
27 ÷ 59.9	<b>17 ÷ 26.9</b>		D - 7.3	3.2	2.5	2.62
60 ÷ 199.9	<b>27 ÷ 59.9</b>	17 ÷ 26.9	D - 10.7	4.2	3.5	3.53
200 ÷ 255.9	<b>60 ÷ 199.9</b>	27 ÷ 59.9	D - 15.1	6.3	5.0	5.34
256 ÷ 669.9	<b>200 ÷ 255.9</b>	60 ÷ 199.9	D - 20.5	8.1	6.5	6.99
670 ÷ 999.9	<b>256 ÷ 669.9</b>	200 ÷ 255.9	D - 24.0	8.1	6.5	6.99
	<b>670 ÷ 999.9</b>	256 ÷ 669.9	D - 27.3	9.5	7.5	8.40
	<b>&gt; 1000</b>		D - 38.0	13.8	10.0	12.0





# KHD

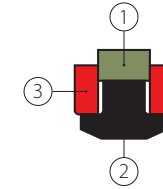

MATERIAL	
① Type	Polytetrafluoroethylene PTFE + Bronze
Designation	SEALFLON + Bronze
② Type	Nitril Rubber NBR
Designation	RUBSEAL 80
Hardness	80 °ShA
③ Type	Acetal resin
Designation	BEARITE

### FIELD OF APPLICATION

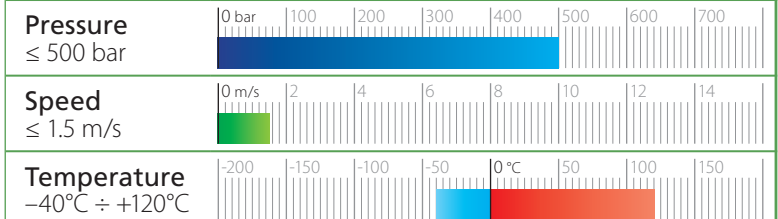

**Fluids** Hydraulic oils (mineral oil based)  
For other fluids contact our technical department

### SURFACE ROUGHNESS

<b>Dynamic surface</b>	Ra ≤ 0.3 µm	Rt ≤ 2.5 µm
<b>Static surface</b>	Ra ≤ 1.6 µm	Rt ≤ 6.3 µm

### GAP DIMENSION "g"

The largest gap dimension appearing in operation on the non-pressurised side:

300 bar	1.0 mm	500 bar	0.6 mm
---------	--------	---------	--------

NB: for the Gap calculation, it is necessary to consider the elastic deformation of metal elements under pressure loads.

### LEAD-IN CHAMFERS

d	Smin
0 ÷ 60	4.5 mm
70 ÷ 120	5.0 mm
125 ÷ 200	6.5 mm

To avoid damaging the sealing lips during installation, housing must have rounded chamfers. Sharp edges and burrs within the installation area of the seal must be removed.

The above data are maximum values, they may be maintained for short periods and can not be used at the same time simultaneously.

The Aston Seals KHD is a double acting piston seal for high pressure operation and is composed of:

- A dynamic seal element which assures exceptional low friction and high speed performance, high compatibility with nearly all media due to the chemical resistance which exceeds that of all other thermoplastics and elastomers
- A rubber element with low permanent deformation as energizing component on the static side
- Two backup rings which offset large gaps or structural deflections without extrusion and assure high longevity
- Low static and dynamic friction

- No tendency of stick-slip
- Space-saving construction and simple groove design
- High resistance against extrusion
- Extended service life

# KHD

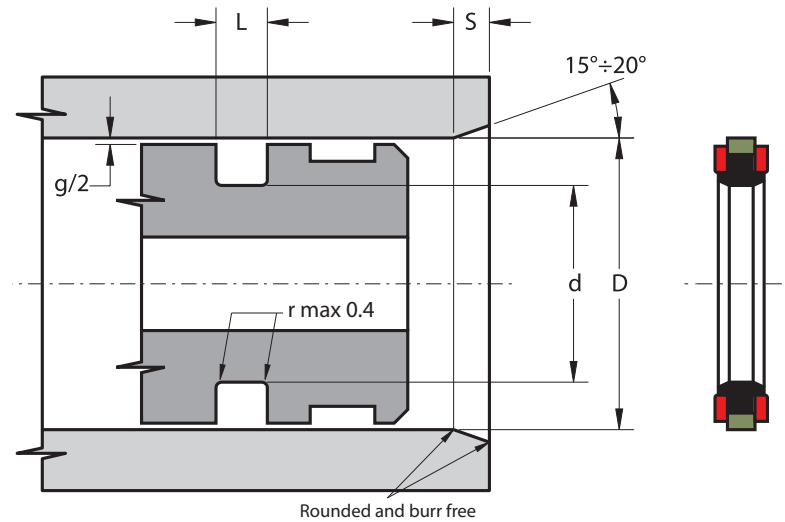

Part.	D <sup>H9</sup>	d <sup>±0.1</sup>	L <sup>+0.2</sup>
KHD 50 36 9	50	36	9
KHD 55 41 9	55	41	9
KHD 60 46 9	60	46	9
KHD 65 50 11	65	50	11
KHD 70 55 11	70	55	11
KHD 75 60 11	75	60	11
KHD 80 65 11	80	65	11
KHD 85 70 11	85	70	11
KHD 90 75 11	90	75	11
KHD 95 80 11	95	80	11
KHD 100 85 12.5	100	85	12.5
KHD 105 90 12.5	105	90	12.5
KHD 110 95 12.5	110	95	12.5
KHD 115 100 12.5	115	100	12.5

Part.	D <sup>H9</sup>	d <sup>±0.1</sup>	L <sup>+0.2</sup>
KHD 120 105 12.5	120	105	12.5
KHD 125 102 16	125	102	16
KHD 130 107 16	130	107	16
KHD 135 112 16	135	112	16
KHD 140 117 16	140	117	16
KHD 145 122 16	145	122	16
KHD 150 127 16	150	127	16
KHD 160 137 16	160	137	16
KHD 165 142 16	165	142	16
KHD 170 147 16	170	147	16
KHD 180 157 16	180	157	16
KHD 185 162 16	185	162	16
KHD 200 177 16	200	177	16
KHD 225 202 16	225	202	16

# YL

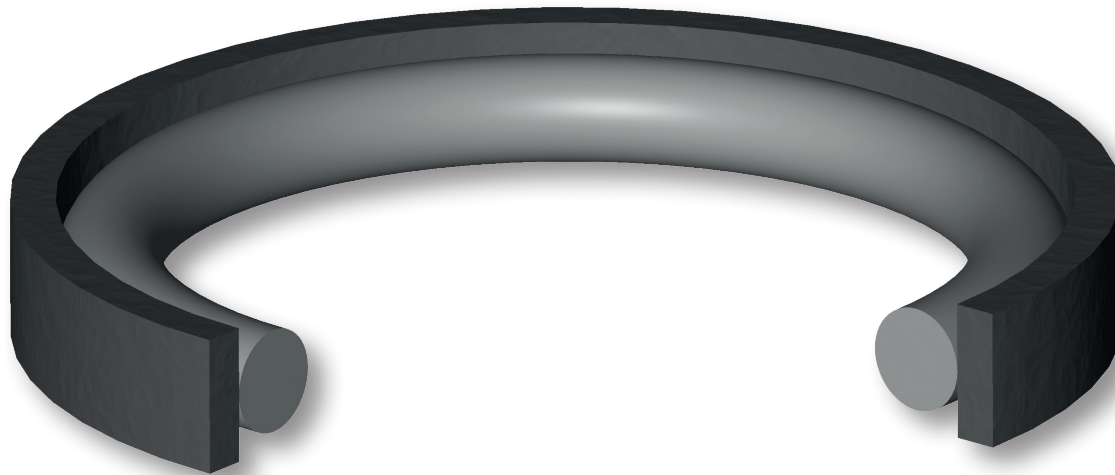

### MATERIAL

- ② **Type** Polytetrafluoroethylene PTFE + Carbon  
**Designation** SEALFLON + Carbon  
 ⇒ It can be provided with different fillers according to applications
- ① **Type** Nitril Rubber NBR  
**Designation** RUBSEAL 70  
**Hardness** 70 °ShA  
 ⇒ It can be provided with different materials according to working conditions

### FIELD OF APPLICATION

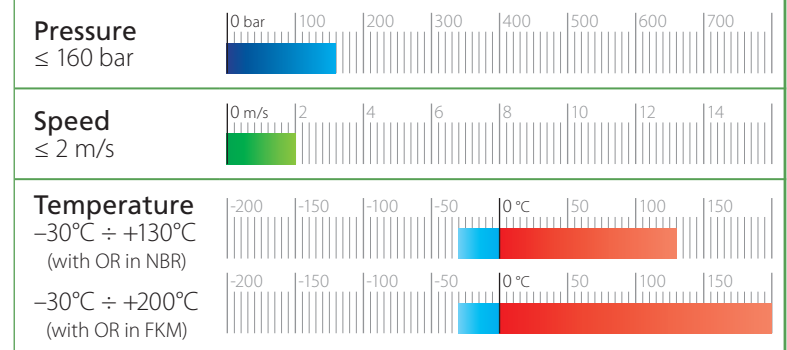

**Fluids** High compatibility with nearly all fluids (with the right choice of O-Ring material)

### SURFACE ROUGHNESS

<b>Dynamic surface</b>	Ra ≤ 0.3 µm	Rt ≤ 2.5 µm
<b>Static surface</b>	Ra ≤ 1.6 µm	Rt ≤ 6.3 µm

### GAP DIMENSION "g"

The largest gap dimension appearing in operation on the non-pressurised side must comply with the ISO H8/f7:

NB: for the Gap calculation, it is necessary to consider the elastic deformation of metal elements under pressure loads.

To avoid damaging the sealing lips during installation, housing must have rounded chamfers. Sharp edges and burrs within the installation area of the seal must be removed.

The above data are maximum values, they may be maintained for short periods and can not be used at the same time simultaneously.

The piston seal type Aston Seals YL, mainly suitable for low pressure conditions or pneumatic field, is composed of:

- A dynamic seal element which assures exceptional low friction and high speed performance, high compatibility with nearly all media due to the chemical resistance which exceeds that of all other thermoplastics and elastomers
- A standard size O-Ring with low permanent deformation as energizing component on the static side

- Low static and dynamic friction, also without lubrication
- No tendency of stick-slip

- Space-saving construction and simple groove design
- Good resistance against extrusion
- High compatibility with nearly all fluids (with the right choice of O-Ring material)
- High speed allowed
- High temperature resistance

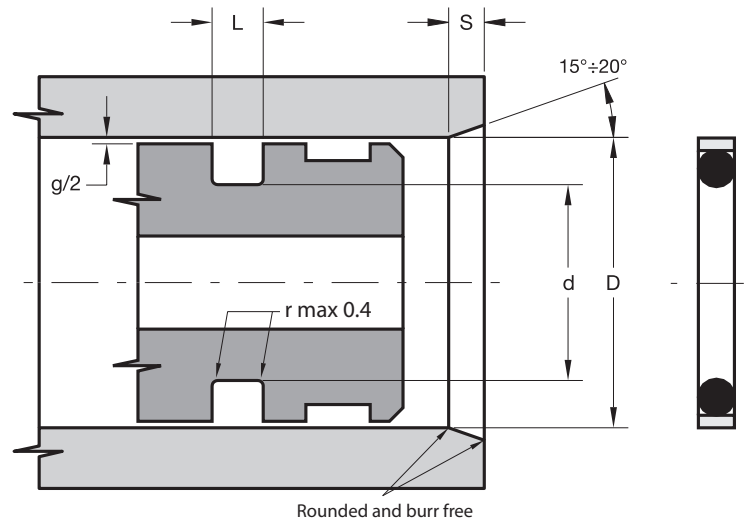

Part.	D <sup>H8</sup>	d <sup>h9</sup>	L <sup>+0.2</sup>	S	OR
YL 007-8	8	3.4	2	3.0	007
YL 008-9	9	4.4	2	3.0	008
YL 009-10	10	5.5	2	3.0	009
YL 010-11	11	6.5	2	3.0	010
YL 011-12	12	7.4	2	3.0	011
YL 012-14	14	9.5	2	3.0	012
YL 013-15	15	10.4	2	3.0	013
YL 613-16	16	9.8	3	3.5	613
YL 111-17	17	10.8	3	3.5	111
YL 614-18	18	11.8	3	3.5	614
YL 113-20	20	13.8	3	3.5	113
YL 114-22	22	15.8	3	3.5	114
YL 116-25	25	18.8	3	3.5	116
YL 211-28	28	20.0	4	4.5	211
YL 212-30	30	22.0	4	4.5	212
YL 213-32	32	24.0	4	4.5	213
YL 215-35	35	27.0	4	4.5	215

Part.	D <sup>H8</sup>	d <sup>h9</sup>	L <sup>+0.2</sup>	S	OR
YL 216-36	36	28.0	4	4.5	216
YL 217-38	38	30.0	4	4.5	217
YL 218-40	40	32.0	4	4.5	218
YL 219-42	42	34.0	4	4.5	219
YL 221-45	45	37.0	4	4.5	221
YL 824-48	48	40.0	4	4.5	824
YL 325-50	50	38.3	6	6.0	325
YL 326-55	55	43.5	6	6.0	326
YL 327-56	56	44.3	6	6.0	327
YL 328-60	60	48.3	6	6.0	328
YL 329-63	63	51.3	6	6.0	329
YL 330-65	65	53.3	6	6.0	330
YL 331-70	70	58.4	6	6.0	331
YL 333-75	75	62.9	6	6.0	333
YL 334-80	80	68.0	6	6.0	334
YL 336-85	85	72.9	6	6.0	336
YL 337-90	90	78.0	6	6.0	337

Part.	D <sup>H8</sup>	d <sup>h9</sup>	L <sup>+0.2</sup>	S	OR
YL 339-95	95	82.9	6	6.0	339
YL 340-100	100	88.0	6	6.0	340
YL 344-110	110	97.9	6	6.0	344
YL 347-120	120	107.9	6	6.0	347
YL 348-125	125	112.5	6	6.0	348
YL 860-130	130	117.5	6	6.0	860
YL 428-140	140	124.5	8	8.0	428
YL 431-150	150	134.5	8	8.0	431
YL 434-160	160	144.5	8	8.0	434
YL 437-170	170	153.7	8	8.0	437
YL 874-180	180	163.7	8	8.0	874
YL 440-190	190	173.7	8	8.0	440
YL 442-200	200	183.7	8	8.0	442
YL 678-250	250	233.7	8	8.0	678
YL 682-280	280	263.7	8	8.0	682
YL 451-300	300	283.7	8	8.0	451

Other sizes not present in the above table can be provided on request

# YP

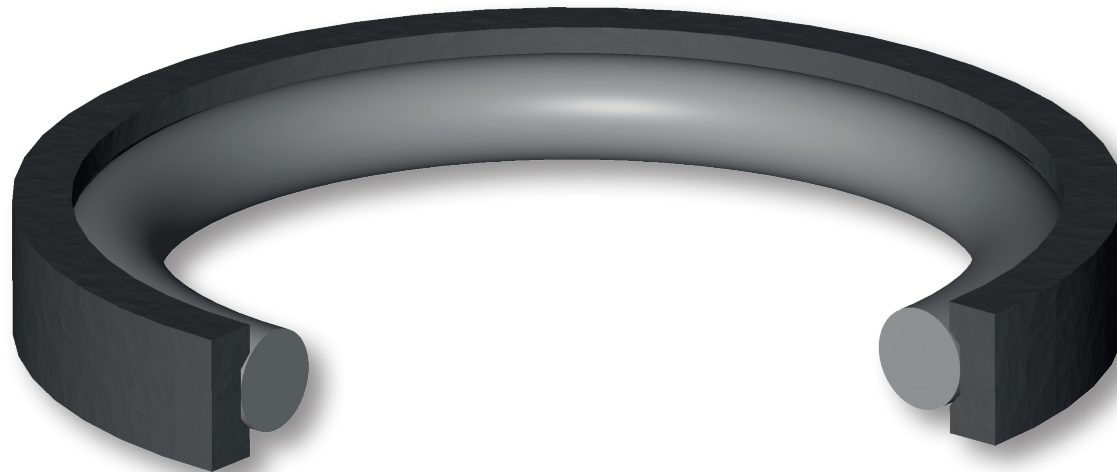

### MATERIAL

	② <b>Type Designation</b> Polytetrafluoroethylene PTFE SEALFLON ⇒ It can be provided with different fillers according to applications
	① <b>Type Designation</b> Nitril Rubber NBR RUBSEAL 70 <b>Hardness</b> 70 °ShA ⇒ It can be provided with different materials according to working conditions

### FIELD OF APPLICATION

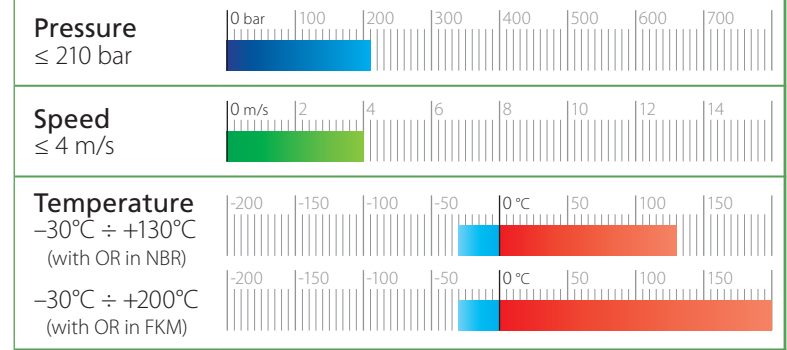

**Fluids** High compatibility with nearly all fluids (with the right choice of O-Ring material)

### SURFACE ROUGHNESS

<b>Dynamic surface</b>	Ra ≤ 0.3 μm	Rt ≤ 2.5 μm
<b>Static surface</b>	Ra ≤ 1.6 μm	Rt ≤ 6.3 μm

### GAP DIMENSION "g"

The largest gap dimension appearing in operation on the non-pressurised side must comply with the ISO H8/f7:

NB: for the Gap calculation, it is necessary to consider the elastic deformation of metal elements under pressure loads.

To avoid damaging the sealing lips during installation, housing must have rounded chamfers. Sharp edges and burrs within the installation area of the seal must be removed.

The above data are maximum values, they may be maintained for short periods and can not be used at the same time simultaneously.

The piston seal type Aston Seals YP, mainly suitable for low pressure conditions or pneumatic field, is composed of:

- A dynamic seal element which assures exceptional low friction and high speed performance, high compatibility with nearly all media due to the chemical resistance which exceeds that of all other thermoplastics and elastomers.
- A standard size O-Ring with low permanent deformation as energizing component on the static side
- Low static and dynamic friction, also without lubrication
- No tendency of stick-slip

- Space-saving construction and simple groove design
- Good resistance against extrusion
- High compatibility with nearly all fluids (with the right choice of O-Ring material)
- High speed allowed
- High temperature resistance

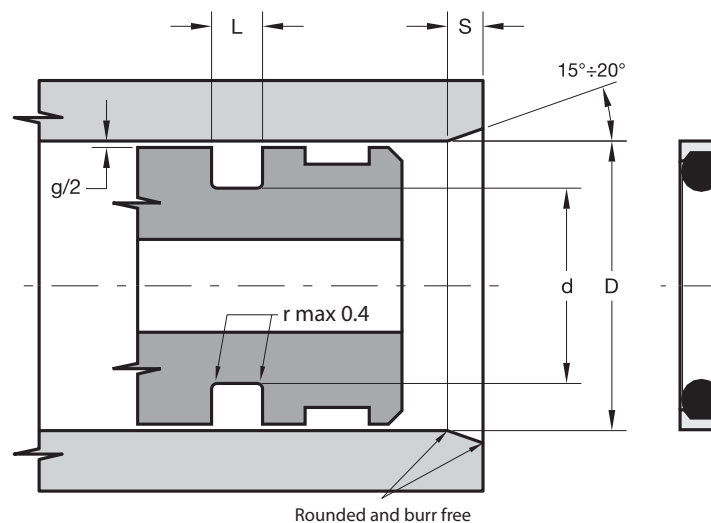

Part.	D <sup>H8</sup>	d <sup>h9</sup>	L <sup>+0.2</sup>	S	OR
YP 004-6	6	2.8	2.5	2.0	004
YP 006-7	7	3.7	2.5	2.0	006
YP 008-8	8	4.7	2.5	2.0	008
YP 009-9	9	5.7	2.5	2.0	009
YP 010-10	10	6.8	2.5	2.0	010
YP 011-11	11	7.6	2.5	2.0	011
YP 012-13	13	9.7	2.5	2.0	012
YP 110-15	15	10.1	3.5	2.5	110
YP 111-16	16	10.9	3.5	2.5	111
YP 112-18	18	13.1	3.5	2.5	112
YP 113-20	20	14.7	3.5	2.5	113
YP 114-21	21	15.9	3.5	2.5	114
YP 115-22	22	16.6	3.5	2.5	115
YP 116-25	25	19.8	3.5	2.5	116
YP 210-26	26	19.1	4.5	3.0	210
YP 211-28	28	21.2	4.5	3.0	211
YP 212-29	29	22.0	4.5	3.0	212
YP 213-30	30	22.9	4.5	3.0	213
YP 214-32	32	25.0	4.5	3.0	214
YP 215-34	34	27.0	4.5	3.0	215
YP 216-35	35	28.0	4.5	3.0	216
YP 217-37	37	30.0	4.5	3.0	217

Part.	D <sup>H8</sup>	d <sup>h9</sup>	L <sup>+0.2</sup>	S	OR
YP 218-38	38	30.9	4.5	3.0	218
YP 219-40	40	32.9	4.5	3.0	219
YP 220-42	42	35.0	4.5	3.0	220
YP 221-43	43	35.9	4.5	3.0	221
YP 222-45	45	37.9	4.5	3.0	222
YP 325-50	50	39.6	7.0	4.0	325
YP 326-52	52	41.8	7.0	4.0	326
YP 327-55	55	44.7	7.0	4.0	327
YP 328-58	58	47.7	7.0	4.0	328
YP 329-61	61	50.5	7.0	4.0	329
YP 330-65	65	54.7	7.0	4.0	330
YP 331-68	68	57.7	7.0	4.0	331
YP 332-70	70	59.5	7.0	4.0	332
YP 333-75	75	64.5	7.0	4.0	333
YP 334-77	77	66.6	7.0	4.0	334
YP 335-80	80	69.6	7.0	4.0	335
YP 336-85	85	74.5	7.0	4.0	336
YP 337-86	86	75.5	7.0	4.0	337
YP 338-90	90	79.5	7.0	4.0	338
YP 339-92	92	81.5	7.0	4.0	339
YP 340-95	95	84.5	7.0	4.0	340
YP 341-100	100	89.6	7.0	4.0	341

Part.	D <sup>H8</sup>	d <sup>h9</sup>	L <sup>+0.2</sup>	S	OR
YP 342-102	102	91.5	7.0	4.0	342
YP 343-105	105	94.5	7.0	4.0	343
YP 344-108	108	97.5	7.0	4.0	344
YP 345-111	111	100.6	7.0	4.0	345
YP 346-115	115	104.5	7.0	4.0	346
YP 347-118	118	107.5	7.0	4.0	347
YP 348-121	121	110.5	7.0	4.0	348
YP 349-125	125	114.5	7.0	4.0	349
YP 425-127	127	113.3	9.5	5.0	425
YP 426-130	130	116.3	9.5	5.0	426
YP 427-135	135	121.3	9.5	5.0	427
YP 428-137	137	123.3	9.5	5.0	428
YP 429-140	140	126.3	9.5	5.0	429
YP 430-143	143	129.3	9.5	5.0	430
YP 431-146	146	132.3	9.5	5.0	431
YP 432-150	150	136.3	9.5	5.0	432
YP 433-153	153	139.3	9.5	5.0	433
YP 434-156	156	142.3	9.5	5.0	434
YP 435-160	160	146.3	9.5	5.0	435
YP 436-162	162	148.3	9.5	5.0	436
YP 437-165	165	151.3	9.5	5.0	437
YP 438-172	172	158.3	9.5	5.0	438

Other sizes not present in the above table can be provided on request

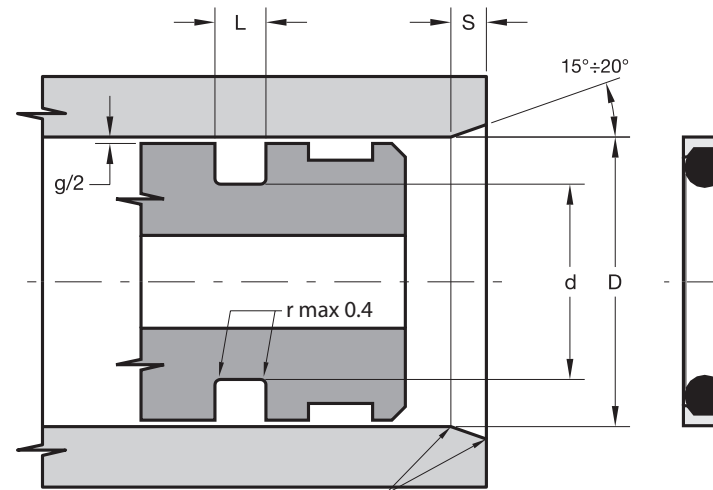

Rounded and burr free

Part.	D <sup>H8</sup>	d <sup>h9</sup>	L <sup>+0.2</sup>	S	OR
<b>YP 439-178</b>	178	164.3	9.5	5.0	439
<b>YP 440-184</b>	184	170.3	9.5	5.0	440
<b>YP 441-191</b>	191	177.3	9.5	5.0	441
<b>YP 442-197</b>	197	183.3	9.5	5.0	442
<b>YP 443-203</b>	203	189.3	9.5	5.0	443
<b>YP 444-210</b>	210	196.3	9.5	5.0	444
<b>YP 445-216</b>	216	202.3	9.5	5.0	445
<b>YP 674-222</b>	222	208.3	9.5	5.0	674
<b>YP 446-230</b>	230	216.3	9.5	5.0	446
<b>YP 676-235</b>	235	221.3	9.5	5.0	676
<b>YP 447-242</b>	242	228.3	9.5	5.0	447
<b>YP 678-250</b>	250	236.3	9.5	5.0	678
<b>YP 448-255</b>	255	241.3	9.5	5.0	448
<b>YP 680-260</b>	260	246.3	9.5	5.0	680
<b>YP 449-270</b>	270	256.3	9.5	5.0	449

Part.	D <sup>H8</sup>	d <sup>h9</sup>	L <sup>+0.2</sup>	S	OR
<b>YP 682-275</b>	275	261.3	9.5	5.0	682
<b>YP 450-280</b>	280	266.3	9.5	5.0	450
<b>YP 684-286</b>	286	272.3	9.5	5.0	684
<b>YP 451-295</b>	295	281.3	9.5	5.0	451
<b>YP 686-300</b>	300	286.3	9.5	5.0	686
<b>YP 452-305</b>	305	291.3	9.5	5.0	452
<b>YP 688-315</b>	315	301.3	9.5	5.0	688
<b>YP 453-320</b>	320	306.3	9.5	5.0	453
<b>YP 454-330</b>	330	316.3	9.5	5.0	454
<b>YP 455-345</b>	345	331.3	9.5	5.0	455
<b>YP 456-355</b>	355	341.3	9.5	5.0	456
<b>YP 457-370</b>	370	356.3	9.5	5.0	457
<b>YP 458-380</b>	380	366.3	9.5	5.0	458
<b>YP 459-395</b>	395	381.3	9.5	5.0	459
<b>YP 460-410</b>	410	396.3	9.5	5.0	460

Other sizes not present in the above table can be provided on request





# YRB

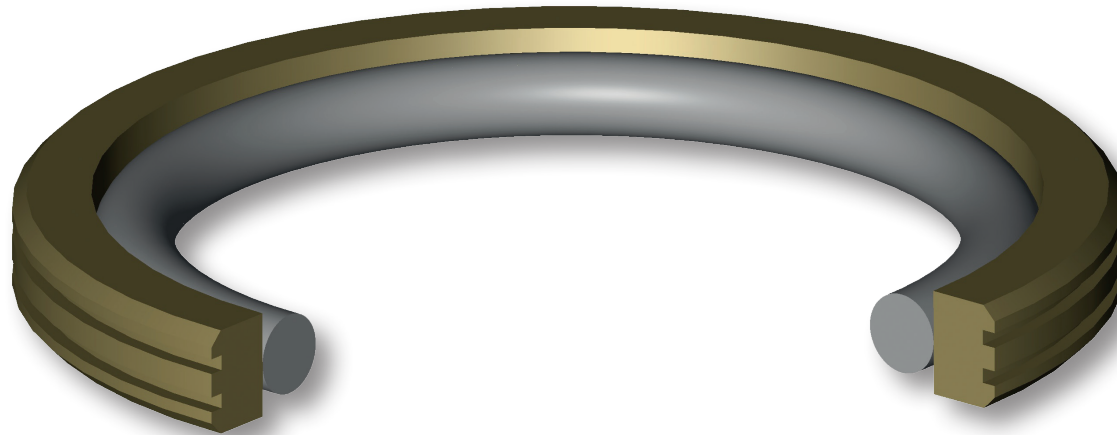

YRB

The piston seal type Aston Seals YRB, used preferably for hydraulic joints and rotary joints, is composed of:

- A dynamic seal element which assures exceptional low friction and high speed performance, high compatibility with nearly all media due to the chemical resistance which exceeds that of all other thermoplastics and elastomers
- A standard size O-Ring with low permanent deformation as energizing component on the static side
- Low static and dynamic friction
- High speed allowed
- No tendency of stick-slip

- Can also work for single action
- Space-saving construction and simple groove design
- High compatibility with nearly all fluids (with the right choice of O-Ring material)
- High resistance against extrusion
- High temperature resistance

## MATERIAL

- ① **Type Designation** Polytetrafluoroethylene PTFE + Bronze  
SEALFLON + Bronze  
⇒ It can be provided with different fillers according to applications
- ② **Type Designation** Nitril Rubber NBR  
RUBSEAL 70  
**Hardness** 70 °ShA  
⇒ It can be provided with different materials according to working conditions

## FIELD OF APPLICATION

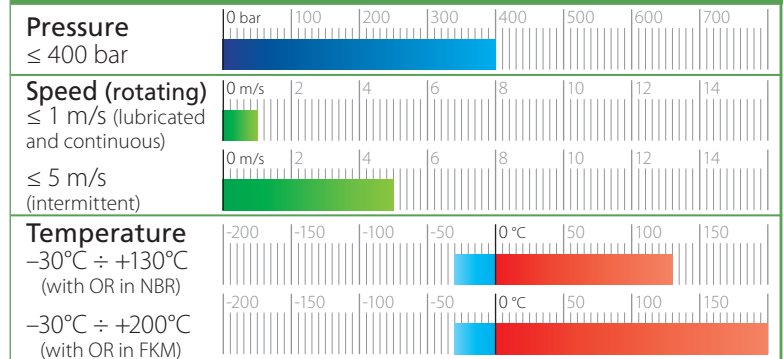

**Fluids** High compatibility with nearly all fluids (with the right choice of O-Ring material)

## SURFACE ROUGHNESS

**Dynamic surface** Ra ≤ 0.3 μm Rt ≤ 2.5 μm  
**Static surface** Ra ≤ 1.6 μm Rt ≤ 6.3 μm

## GAP DIMENSION "g"

The largest gap dimension [mm] appearing in operation on the non-pressurised side:

L	100 bar	200 bar	300 bar
2.2	0.30	0.20	0.10
3.2	0.50	0.30	0.20
4.2	0.50	0.30	0.20
6.3	0.60	0.40	0.30
8.1	0.60	0.40	0.30
9.5	0.90	0.60	0.50

> 400 bar ⇒  $g_{max} = H8/f8$

NB: for the Gap calculation, it is necessary to consider the elastic deformation of metal elements under pressure loads.

To avoid damaging the sealing lips during installation, housing must have rounded chamfers. Sharp edges and burrs within the installation area of the seal must be removed.

The above data are maximum values, they may be maintained for short periods and can not be used at the same time simultaneously.

# YRB

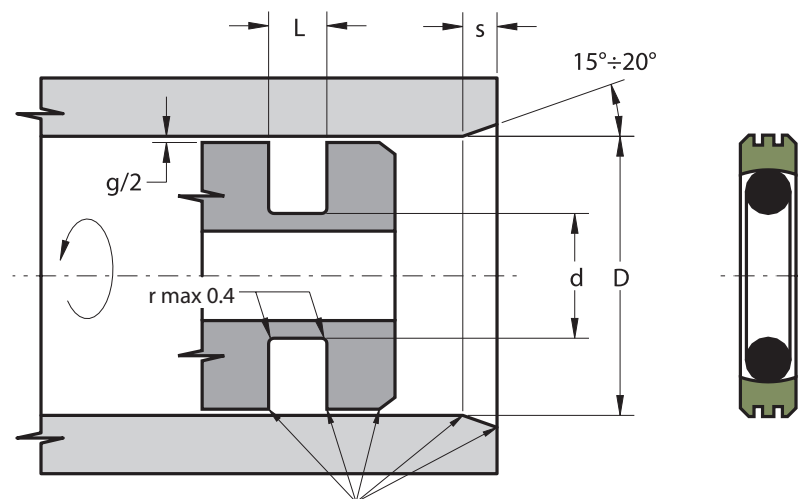

Rounded and burr free

Part.	D <sup>H10</sup>	d <sup>h9</sup>	L <sup>+0.2</sup>	S	OR
YRB 8 3.1 2.2	8	3.1	2.2	2.0	006
YRB 10 5.1 2.2	10	5.1	2.2	2.0	009
YRB 12 7.1 2.2	12	7.1	2.2	2.0	610
YRB 15 10.1 2.2	15	10.1	2.2	2.0	012
YRB 16 11.1 2.2	16	11.1	2.2	2.0	013
YRB 18 13.1 2.2	18	13.1	2.2	2.0	014
YRB 20 15.1 2.2	20	15.1	2.2	2.0	015
YRB 22 17.1 2.2	22	17.1	2.2	2.0	016
YRB 25 20.1 2.2	25	20.1	2.2	2.0	018
YRB 28 23.1 2.2	28	23.1	2.2	2.0	020
YRB 30 25.1 2.2	30	25.1	2.2	2.0	022
YRB 32 27.1 2.2	32	27.1	2.2	2.0	023
YRB 35 30.1 2.2	35	30.1	2.2	2.0	025
YRB 38 33.1 2.2	38	33.1	2.2	2.0	027
YRB 40 32.5 3.2	40	32.5	3.2	2.5	125
YRB 42 34.5 3.2	42	34.5	3.2	2.5	126
YRB 45 37.5 3.2	45	37.5	3.2	2.5	127
YRB 48 40.5 3.2	48	40.5	3.2	2.5	130
YRB 50 42.5 3.2	50	42.5	3.2	2.5	131
YRB 55 47.5 3.2	55	47.5	3.2	2.5	134
YRB 60 52.5 3.2	60	52.5	3.2	2.5	137
YRB 63 55.5 3.2	63	55.5	3.2	2.5	139
YRB 65 57.5 3.2	65	57.5	3.2	2.5	140
YRB 70 62.5 3.2	70	62.5	3.2	2.5	144

Part.	D <sup>H10</sup>	d <sup>h9</sup>	L <sup>+0.2</sup>	S	OR
YRB 75 67.5 3.2	75	67.5	3.2	2.5	147
YRB 80 69 4.2	80	69.0	4.2	3.5	232
YRB 85 74 4.2	85	74.0	4.2	3.5	845
YRB 90 79 4.2	90	79.0	4.2	3.5	235
YRB 95 84 4.2	95	84.0	4.2	3.5	236
YRB 100 89 4.2	100	89.0	4.2	3.5	238
YRB 105 94 4.2	105	94.0	4.2	3.5	240
YRB 110 99 4.2	110	99.0	4.2	3.5	241
YRB 115 104 4.2	115	104.0	4.2	3.5	243
YRB 120 109 4.2	120	109.0	4.2	3.5	244
YRB 125 114 4.2	125	114.0	4.2	3.5	246
YRB 130 119 4.2	130	119.0	4.2	3.5	247
YRB 140 125.5 6.3	140	124.5	6.3	5.0	352
YRB 150 134.5 6.3	150	134.5	6.3	5.0	355
YRB 160 144.5 6.3	160	144.5	6.3	5.0	358
YRB 170 154.5 6.3	170	154.5	6.3	5.0	361
YRB 180 164.5 6.3	180	164.5	6.3	5.0	363
YRB 190 174.5 6.3	190	174.5	6.3	5.0	364
YRB 200 184.5 6.3	200	184.5	6.3	5.0	366
YRB 210 194.5 6.3	210	194.5	6.3	5.0	367
YRB 220 204.5 6.3	220	204.5	6.3	5.0	369
YRB 240 224.5 6.3	240	224.5	6.3	5.0	372
YRB 250 234.5 6.3	250	234.5	6.3	5.0	374
YRB 280 264.5 6.3	280	264.5	6.3	5.0	377

Part.	D <sup>H10</sup>	d <sup>h9</sup>	L <sup>+0.2</sup>	S	OR
YRB 300 284.5 6.3	300	284.5	6.3	5.0	379
YRB 320 304.5 6.3	320	304.5	6.3	5.0	381
YRB 350 329 8.1	350	329.0	8.1	6.5	455
YRB 360 339 8.1	360	339.0	8.1	6.5	456
YRB 400 379 8.1	400	379.0	8.1	6.5	458
YRB 420 399 8.1	420	399.0	8.1	6.5	460
YRB 450 429 8.1	450	429.0	8.1	6.5	463
YRB 480 459 8.1	480	459.0	8.1	6.5	465
YRB 500 479 8.1	500	479.0	8.1	6.5	467
YRB 520 499 8.1	520	499.0	8.1	6.5	468
YRB 550 529 8.1	550	529.0	8.1	6.5	470
YRB 600 579 8.1	600	579.0	8.1	6.5	472
YRB 650 629 8.1	650	629.0	8.1	6.5	474
YRB 700 672 9.5	700	672.0	9.5	7.5	670x8.4
YRB 750 722 9.5	750	722.0	9.5	7.5	720x8.4

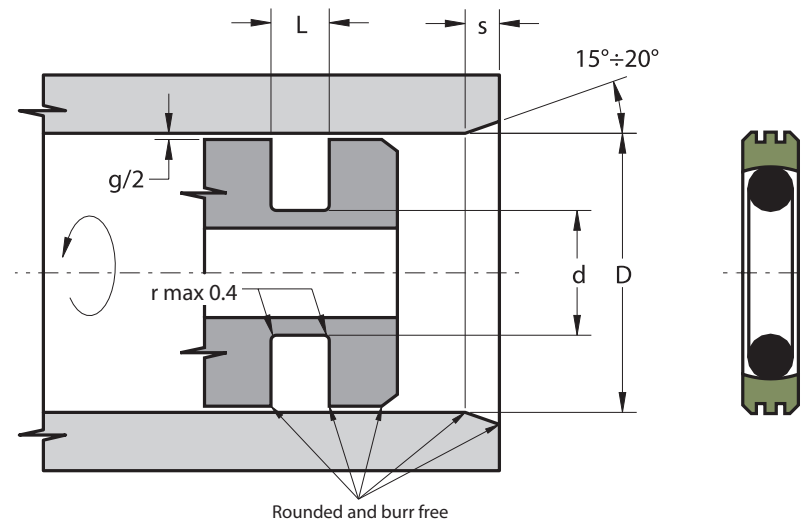

Other sizes not present in the above table can be provided in according to the following scheme:

d	D	L	S	S. OR
8 ÷ 39.9	D - 4.9	2.20	2.0	1.78
40 ÷ 79.9	D - 7.5	3.20	2.5	2.62
80 ÷ 132.9	D - 11.0	4.20	3.5	3.53
133 ÷ 329.9	D - 15.5	6.30	5.0	5.34
330 ÷ 669.9	D - 21.0	8.10	6.5	6.99
670 ÷ 999.9	D - 28.0	9.50	7.5	8.40



# UP



### MATERIAL

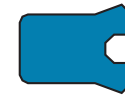

<b>Type</b>	<b>Designation</b>	<b>Hardness</b>
Polyurethane	SEALPUR 93	93 °ShA

### FIELD OF APPLICATION

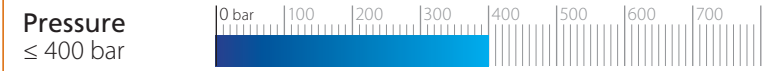

**Fluids** Hydraulic oils (mineral oil based)  
For other fluids contact our technical department

### SURFACE ROUGHNESS

<b>Dynamic surface</b>	Ra ≤ 0.3 µm	Rt ≤ 2.5 µm
<b>Static surface</b>	Ra ≤ 1.6 µm	Rt ≤ 6.3 µm

### GAP DIMENSION "g"

The largest gap dimension appearing in operation on the non-pressurised side:

50 bar	1.20 mm	300 bar	0.25 mm
100 bar	0.80 mm	400 bar	0.17 mm
200 bar	0.40 mm		

### LEAD-IN CHAMFERS

d	Smin
less 100	5 mm
100÷200	7 mm
over 200	10 mm

To avoid damaging the sealing lips during installation, housing must have rounded chamfers. Sharp edges and burrs within the installation area of the seal must be removed.

The above data are maximum values, they may be maintained for short periods and can not be used at the same time simultaneously.

The seal type Aston Seals UP is a high performance all purpose lipseal suitable for both rod and piston.

The UP profile assures a good reaction against shock pressure peaks and low friction in all conditions.

The material used to produce this seal is a polyurethane compound that ensures excellent properties on wear-resistance, extended service life and resistance against extrusion.

- Suitable for both rod and piston
- Economical solution
- Excellent wear-resistance

- Extended service life
- High resistance against extrusion
- Good temperature resistance
- Easy installation without expensive auxiliaries

# UP

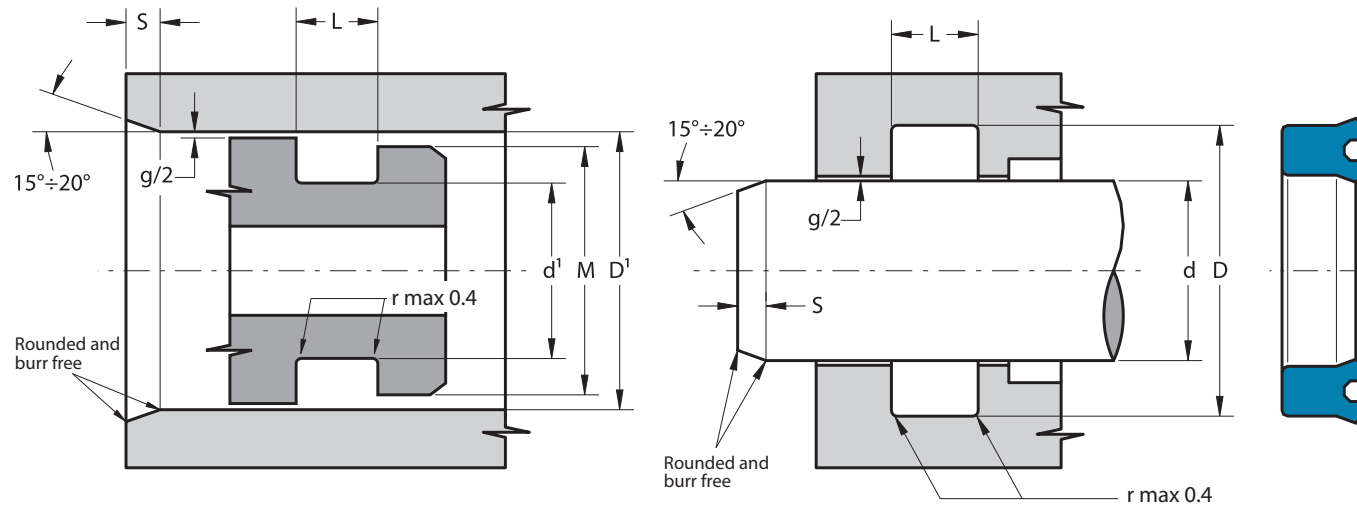

Part.	$d_{f7}^{1 f8}$	$D_{H10}^{1 H10}$	$L_{+0.25}$	M
UP 3 8 4	3	8	4.5	5
UP 3 9 4.5	3	9	5.0	5
UP 4 10 4	4	10	4.5	6
UP 4 10 4.5	4	10	5.0	6
UP 4.5 11 5	4.5	11	5.5	6.5
UP 5 12 4.5	5	12	5.0	7
UP 5 12 5	5	12	5.5	7
UP 5 12 6	5	12	7.0	7
UP 5 17 9	5	17	10.0	11
UP 6 12 4	6	12	4.5	8
UP 6 12 5.2	6	12	5.7	8
UP 6 12 5.5	6	12	6.0	8
UP 6 12 6	6	12	7.0	8
UP 6 12 8	6	12	9.0	8
UP 6 12.7 6	6	12.7	7.0	8
UP 6 15 8	6	15	9.0	9
UP 6.35 11.11 5	6.35	11.11	5.5	8.5
UP 7 14 3.5	7	14	4.2	9
UP 7 15 7	7	15	8.0	9
UP 8 12 2.4	8	12	3.5	10
UP 8 14 6	8	14	7.0	10
UP 8 15 5.8	8	15	6.3	10
UP 8 15 8	8	15	9.0	10
UP 8 16 4	8	16	4.5	10

Part.	$d_{f7}^{1 f8}$	$D_{H10}^{1 H10}$	$L_{+0.25}$	M
UP 8 16 5.8	8	16	6.3	10
UP 8 18 9	8	18	10.0	11
UP 8.4 16 5.8	8.4	16	6.3	10
UP 10 16 4	10	16	4.5	12
UP 10 16 5.6	10	16	6.2	12
UP 10 16 6	10	16	7.0	12
UP 10 18 5	10	18	6.0	12
UP 10 18 6	10	18	7.0	12
UP 10 18 8	10	18	9.0	12
UP 10 20 8	10	20	9.0	12
UP 10 22 8	10	22	9.0	13
UP 12 18 4.5	12	18	5.0	14
UP 12 18 5	12	18	5.5	14
UP 12 18 6	12	18	7.0	14
UP 12 20 8	12	20	9.0	14
UP 12 22 5	12	22	6.0	15
UP 12 22 7	12	22	8.0	15
UP 12 22 8	12	22	9.0	15
UP 12 24 8	12	24	9.0	15
UP 14 20 4.8	14	20	5.3	16
UP 14 22 6	14	22	7.0	16
UP 14 24 8	14	24	9.0	16
UP 14 27 7	14	27	8.0	16
UP 15 21.5 4.5	15	21.5	5.0	17

Part.	$d_{f7}^{1 f8}$	$D_{H10}^{1 H10}$	$L_{+0.25}$	M
UP 15 25 8	15	25	9.0	18
UP 15 25 10	15	25	11.0	18
UP 16 22 4	16	22	4.5	18
UP 16 22 5	16	22	5.5	18
UP 16 22 5.5	16	22	6.0	18
UP 16 24 5	16	24	6.0	18
UP 16 24 8	16	24	9.0	18
UP 16 24 9	16	24	10.0	18
UP 16 26 5	16	26	6.0	19
UP 16 26 8	16	26	9.0	19
UP 16 28 6	16	28	7.0	19
UP 16 28 9	16	28	10.0	19
UP 16 32 8	16	32	9.0	20
UP 17 23 4	17	23	4.5	19
UP 17 25 4	17	25	4.5	19
UP 17 25 6	17	25	7.0	19
UP 17 25 10	17	25	11.0	19
UP 17 27 6.5	17	27	7.6	19
UP 18 25 5	18	25	5.5	20
UP 18 26 6.5	18	26	7.5	20
UP 18 26 8	18	26	9.0	20
UP 18 26 8.5	18	26	9.5	20
UP 18 28 8	18	28	9.0	21
UP 18 30 8	18	30	9.0	21

UP

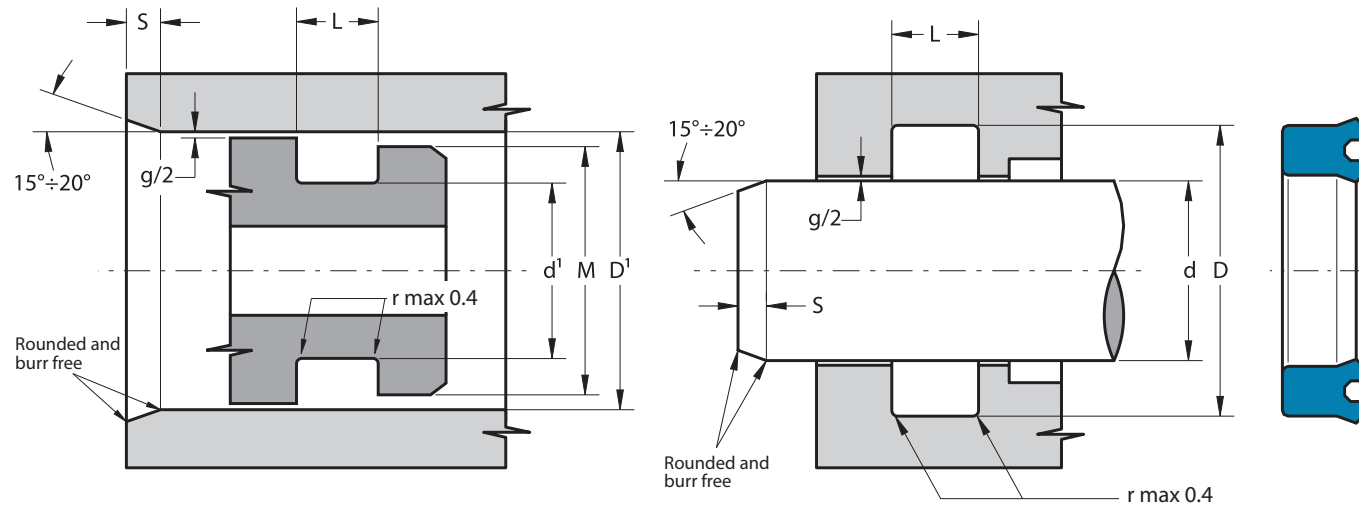

Part.	d <sup>1 f8</sup> d <sub>f7</sub>	D <sup>1 H10</sup> D <sub>H10</sub>	L <sup>+0.25</sup>	M
UP 19 25 6	19	25	7.0	21
UP 20 26 5	20	26	5.5	22
UP 20 28 4	20	28	5.0	22
UP 20 28 5	20	28	5.5	22
UP 20 28 5.7	20	28	6.2	22
UP 20 28 7	20	28	8.0	22
UP 20 28 8	20	28	9.0	22
UP 20 29 5	20	29	5.5	22
UP 20 30 7	20	30	8.0	23
UP 20 30 8	20	30	9.0	23
UP 20 30 10	20	30	11.0	23
UP 20 32 7.5	20	32	8.5	23
UP 20 35 9	20	35	10.0	24
UP 20 40 10	20	40	11.0	24
UP 22 27 2.6	22	27	3.0	24
UP 22 28 8	22	28	9.0	24
UP 22 30 6	22	30	7.0	24
UP 22 32 8	22	32	9.0	25
UP 22 32 10	22	32	11.0	25
UP 22 35 10	22	35	11.0	25
UP 22 40 10	22	40	11.0	25
UP 24 32 6	24	32	7.0	26
UP 24 32 7	24	32	8.0	26
UP 24 34 5	24	34	5.5	27

Part.	d <sup>1 f8</sup> d <sub>f7</sub>	D <sup>1 H10</sup> D <sub>H10</sub>	L <sup>+0.25</sup>	M
UP 25 33 5	25	33	5.5	27
UP 25 33 6	25	33	7.0	27
UP 25 35 5	25	35	5.5	28
UP 25 35 8	25	35	9.0	28
UP 25 35 10	25	35	11.0	28
UP 25 38 8	25	38	9.0	28
UP 25 38 10	25	38	11.0	28
UP 25 40 7	25	40	8.0	28
UP 25 40 10	25	40	11.0	28
UP 27 36.5 6.8	27	36.5	7.8	30
UP 28 35 4.7	28	35	5.5	30
UP 28 35.5 5	28	35.5	5.5	30
UP 28 36 6.5	28	36	7.5	30
UP 28 38 7	28	38	8.0	31
UP 28 38 8	28	38	9.0	31
UP 28 38 10	28	38	11.0	31
UP 28 40 10	28	40	11.0	31
UP 28 50 10	28	50	11.0	33
UP 30 36 4	30	36	4.5	32
UP 30 37 6	30	37	7.0	32
UP 30 38 4	30	38	4.5	32
UP 30 38 5.8	30	38	6.3	32
UP 30 38 6	30	38	6.5	32
UP 30 38 7	30	38	8.0	32

Part.	d <sup>1 f8</sup> d <sub>f7</sub>	D <sup>1 H10</sup> D <sub>H10</sub>	L <sup>+0.25</sup>	M
UP 30 40 5	30	40	5.5	33
UP 30 40 6	30	40	7.0	33
UP 30 40 10	30	40	11.0	33
UP 30 42 9	30	42	10.0	33
UP 30 42 10	30	42	11.0	33
UP 30 45 10	30	45	11.0	34
UP 30 50 10	30	50	11.0	34
UP 30 50 12	30	50	13.0	34
UP 32 40 5.5	32	40	6.0	34
UP 32 40 8	32	40	9.0	34
UP 32 42 10	32	42	11.0	35
UP 32 45 10	32	45	11.0	35
UP 34 45 7	34	45	8.0	37
UP 34 45 9	34	45	10.0	37
UP 35 43 6	35	43	7.0	37
UP 35 45 5	35	45	5.5	38
UP 35 45 6	35	45	7.0	38
UP 35 45 7	35	45	8.0	38
UP 35 45 8	35	45	9.0	38
UP 35 45 10	35	45	11.0	38
UP 35 48 10	35	48	11.0	38
UP 35 50 10	35	50	11.0	39
UP 35 55 10	35	55	11.0	39
UP 35 55 12	35	55	13.0	39



UP

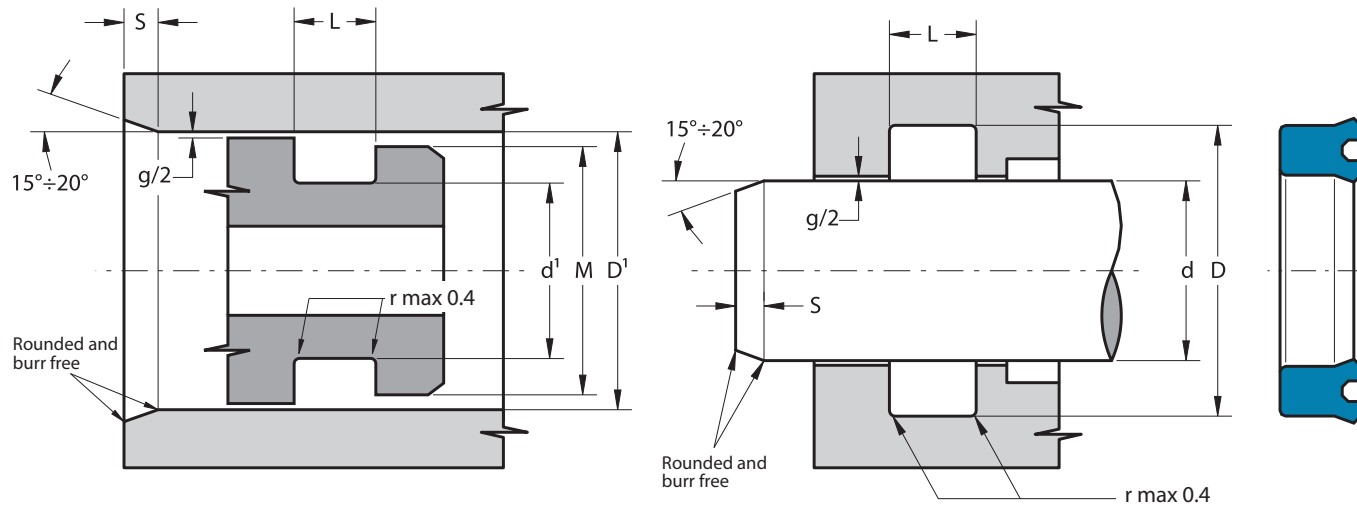

Part.	d <sup>1</sup> f <sub>7</sub> d <sup>18</sup>	D <sup>1</sup> H <sub>10</sub> D <sup>10</sup>	L <sup>+0.25</sup>	M
UP 36 46 7	36	46	8.0	39
UP 36 48 8	36	48	9.0	39
UP 38 45 5	38	45	5.5	40
UP 38 46 6.5	38	46	7.5	40
UP 38 50 9	38	50	10.0	41
UP 38 55 10	38	55	11.0	41
UP 38 58 10	38	58	11.0	42
UP 40 48 5.8	40	48	6.3	42
UP 40 48 8	40	48	9.0	42
UP 40 50 5	40	50	5.5	43
UP 40 50 6	40	50	7.0	43
UP 40 50 6.5	40	50	7.5	43
UP 40 50 8	40	50	9.0	43
UP 40 50 10	40	50	11.0	43
UP 40 55 10	40	55	11.0	44
UP 40 60 10	40	60	11.0	45
UP 40 60 13	40	60	14.0	45
UP 42 50 6	42	50	7.0	44
UP 42 50 8	42	50	9.0	44
UP 42 52 9	42	52	10.0	45
UP 42 62 12	42	62	13.0	47
UP 45 53 6.5	45	53	7.5	48
UP 45 55 6	45	55	7.0	48
UP 45 55 6.5	45	55	7.5	48

Part.	d <sup>1</sup> f <sub>7</sub> d <sup>18</sup>	D <sup>1</sup> H <sub>10</sub> D <sup>10</sup>	L <sup>+0.25</sup>	M
UP 45 55 10	45	55	11.0	48
UP 45 56 7	45	56	8.0	48
UP 45 60 10	45	60	11.0	49
UP 45 63 10	45	63	11.0	49
UP 45 65 10	45	65	11.0	50
UP 45 65 12	45	65	13.0	50
UP 48 58 10	48	58	11.0	51
UP 50 60 5	50	60	5.5	53
UP 50 60 6	50	60	7.0	53
UP 50 60 7	50	60	8.0	53
UP 50 60 10	50	60	11.0	53
UP 50 60 11	50	60	12.0	53
UP 50 62 9	50	62	10.0	53
UP 50 63 6	50	63	7.0	54
UP 50 65 7	50	65	8.0	54
UP 50 65 10	50	65	11.0	54
UP 50 70 10	50	70	11.0	55
UP 50 70 12	50	70	13.0	55
UP 52 62 12	52	62	13.0	55
UP 53 63 6.5	53	63	7.5	56
UP 55 65 6	55	65	7.0	58
UP 55 65 10	55	65	11.0	58
UP 55 65 12	55	65	13.0	58
UP 55 70 12	55	70	13.0	59

Part.	d <sup>1</sup> f <sub>7</sub> d <sup>18</sup>	D <sup>1</sup> H <sub>10</sub> D <sup>10</sup>	L <sup>+0.25</sup>	M
UP 55 75 12	55	75	13.0	60
UP 55 80 12	55	80	13.0	60
UP 56 66 5	56	66	5.5	59
UP 56 66 6	56	66	7.0	59
UP 60 70 5	60	70	5.5	63
UP 60 70 6	60	70	7.0	63
UP 60 70 8	60	70	9.0	63
UP 60 70 10	60	70	11.0	63
UP 60 70 12	60	70	13.0	63
UP 60 71 7	60	71	8.0	63
UP 60 75 10	60	75	11.0	64
UP 60 75 12	60	75	13.0	64
UP 60 80 10	60	80	11.0	65
UP 60 80 12	60	80	13.0	65
UP 60 80 18	60	80	19.0	65
UP 63 73 6	63	73	7.0	66
UP 63 75 10	63	75	11.0	66
UP 63 78 10	63	78	11.0	67
UP 65 75 6	65	75	7.0	68
UP 65 75 12	65	75	13.0	68
UP 65 80 10	65	80	11.0	69
UP 65 80 11	65	80	12.0	69
UP 65 80 12	65	80	13.0	69
UP 65 85 12	65	85	13.0	70

UP

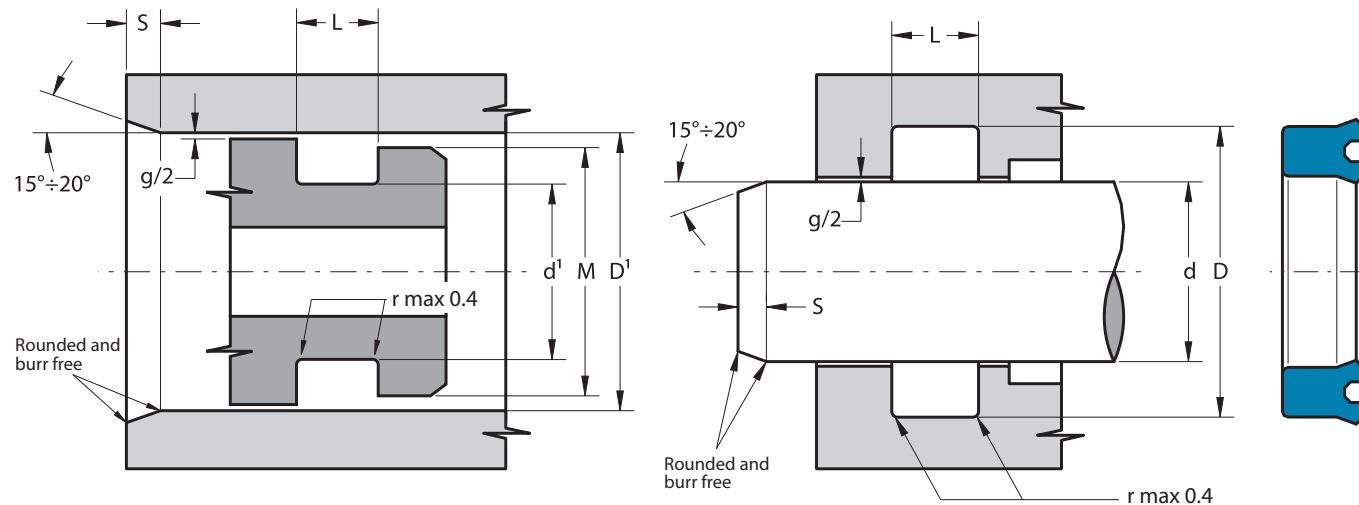

Part.	d <sup>1 f8</sup> d <sub>f7</sub>	D <sup>1 H10</sup> D <sub>H10</sub>	L <sup>+0.25</sup>	M
UP 67 77 10	67	77	11.0	70
UP 67.3 80 6.5	67.3	80	7.5	71
UP 68 92.4 14	68	92.4	15.0	74
UP 70 75 3.5	70	75	4.1	72
UP 70 80 5	70	80	6.0	73
UP 70 80 6	70	80	7.0	73
UP 70 80 8	70	80	9.0	73
UP 70 80 10	70	80	11.0	73
UP 70 80 12	70	80	13.0	73
UP 70 85 11	70	85	12.0	74
UP 70 85 12	70	85	13.0	74
UP 70 90 12	70	90	13.0	75
UP 70 90 18	70	90	19.0	75
UP 75 85 6	75	85	7.0	78
UP 75 85 12	75	85	13.0	78
UP 75 90 7.5	75	90	8.5	79
UP 75 90 10	75	90	11.0	79
UP 75 90 12	75	90	13.0	79
UP 75 95 10	75	95	11.0	80
UP 75 95 12	75	95	13.0	80
UP 75 95 13.5	75	95	14.5	80
UP 75 95 14.5	75	95	15.5	80
UP 77.5 87.5 10	77.5	87.5	11.0	81
UP 80 90 5	80	90	6.0	83

Part.	d <sup>1 f8</sup> d <sub>f7</sub>	D <sup>1 H10</sup> D <sub>H10</sub>	L <sup>+0.25</sup>	M
UP 80 90 6	80	90	7.0	83
UP 80 90 8	80	90	9.0	83
UP 80 90 10	80	90	11.0	83
UP 80 90 12	80	90	13.0	83
UP 80 95 12	80	95	13.0	84
UP 80 100 9.5	80	100	10.5	85
UP 80 100 12	80	100	13.0	85
UP 85 95 8.5	85	95	9.5	88
UP 85 95 12	85	95	13.0	88
UP 85 100 9	85	100	10.0	89
UP 85 100 10	85	100	11.0	89
UP 85 100 12	85	100	13.0	89
UP 85 105 12	85	105	13.0	90
UP 90 100 8	90	100	9.0	93
UP 90 100 12	90	100	13.0	93
UP 90 105 12	90	105	13.0	94
UP 90 110 12	90	110	13.0	95
UP 90 115 12	90	115	13.0	95
UP 90 115 15	90	115	16.0	95
UP 95 110 9	95	110	10.0	99
UP 95 110 12	95	110	13.0	99
UP 95 115 12	95	115	13.0	100
UP 100 115 9	100	115	10.0	104
UP 100 115 12	100	115	13.0	104

Part.	d <sup>1 f8</sup> d <sub>f7</sub>	D <sup>1 H10</sup> D <sub>H10</sub>	L <sup>+0.25</sup>	M
UP 100 120 12	100	120	13.0	105
UP 100 125 12	100	125	13.0	105
UP 100 125 15	100	125	16.0	105
UP 105 120 8	105	120	9.0	109
UP 105 120 15	105	120	16.0	109
UP 105 125 12	105	125	13.0	110
UP 105 125 15	105	125	16.0	110
UP 110 125 9	110	125	10.0	114
UP 110 125 12	110	125	13.0	114
UP 110 125 15	110	125	16.0	114
UP 110 130 15	110	130	16.0	115
UP 115 135 15	115	135	16.0	118
UP 120 140 15	120	140	16.0	125
UP 125 140 9	125	140	10.0	129
UP 125 140 11	125	140	12.0	129
UP 125 140 15	125	140	16.0	129
UP 125 145 15	125	145	16.0	130
UP 130 145 12	130	145	13.0	134
UP 130 150 15	130	150	16.0	135
UP 140 155 9	140	155	10.0	144
UP 140 160 12	140	160	13.0	145
UP 140 160 15	140	160	16.0	145
UP 145 165 15	145	165	16.0	150
UP 150 170 15	150	170	16.0	155

UP

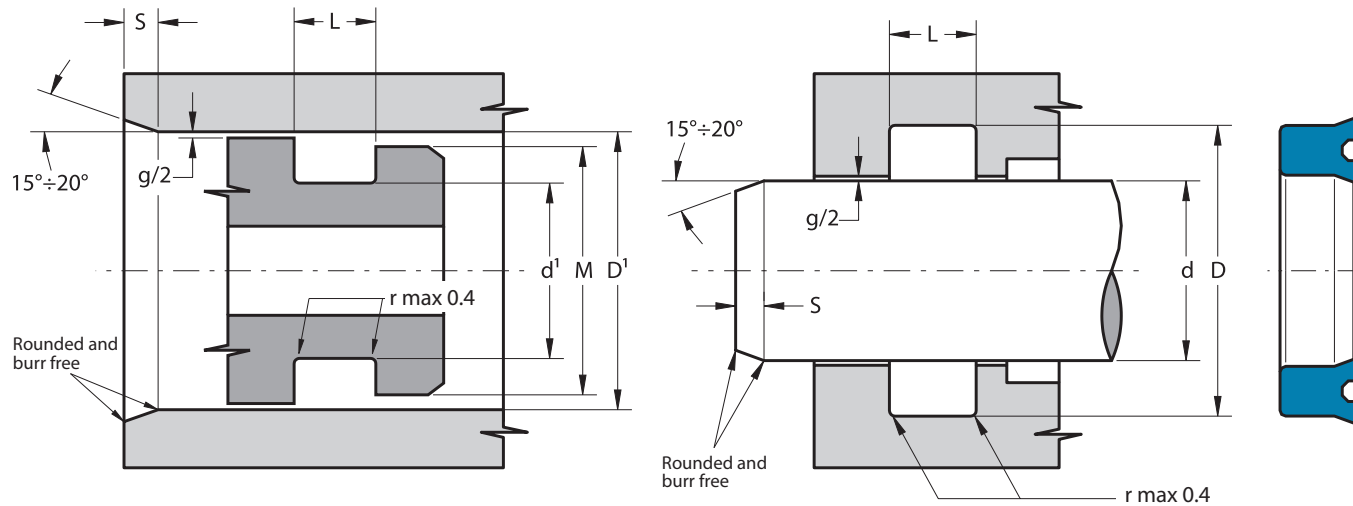

Part.	d <sup>1</sup> f <sub>7</sub> d <sup>1</sup> f <sub>7</sub>	D <sup>1</sup> H <sub>10</sub> D <sup>1</sup> H <sub>10</sub>	L <sup>+</sup> 0.25	M
UP 160 175 12	160	175	13.0	164
UP 160 180 15	160	180	16.0	165
UP 170 190 12	170	190	13.0	175
UP 170 190 15	170	190	16.0	175
UP 175 200 15	175	200	16.0	180
UP 180 200 15	180	200	16.0	185
UP 180 205 18	180	205	19.0	186
UP 190 210 15	190	210	16.0	195
UP 200 220 12	200	220	13.0	205
UP 200 220 15	200	220	16.0	205
UP 200 225 18	200	225	19.0	206
UP 220 250 18	220	250	19.0	225

Inch sizes

UP 1500 2000 0250	38.10	50.80	7.35	41.9
-------------------	-------	-------	------	------

Part.	d <sup>1</sup> f <sub>7</sub> d <sup>1</sup> f <sub>7</sub>	D <sup>1</sup> H <sub>10</sub> D <sup>1</sup> H <sub>10</sub>	L <sup>+</sup> 0.25	M
UP 2000 2500 0250	50.80	63.50	7.35	54.6
UP 2000 2625 0562	50.80	66.68	14.78	55.5
UP 2125 2625 0406	53.97	66.68	11.00	58.0
UP 2250 2625 0375	57.15	66.68	10.50	60.3
UP 2500 3250 0620	63.50	82.55	16.75	68.5
UP 2625 3000 0187	66.68	76.20	5.25	69.9
UP 3000 3625 0562	76.20	92.08	14.78	80.9
UP 3000 3750 0620	76.20	95.25	16.75	81.0
UP 3500 3875 0375	88.90	98.43	10.50	92.0
UP 3500 4000 0375	88.90	101.60	10.50	93.0
UP 3500 4250 0620	88.90	107.95	16.75	94.0
UP 3875 4250 0187	98.43	107.95	5.25	101.6
UP 5250 6000 0620	133.36	152.40	16.75	138.0
UP 6250 7000 0620	158.75	177.80	16.75	163.7
UP 6500 7500 0765	165.10	190.50	20.40	170.0
UP 7000 8000 0750	177.80	203.20	20.10	184.0

# UPN



UPN

The seal type Aston Seals UPN is the natural further development of the UP seal. It is a high performance all purpose lipseal suitable for both rod and piston which combines the advantage of a highly elastic rubber and the abrasion resistance of polyurethane.

The UPN profile assures a good reaction against shock pressure peaks and low friction in all conditions.

The energizing O-Ring guarantees a good sealing performance in the low pressure range. The material used to produce this seal is a polyurethane compound that ensures excellent properties on wear-resistance, extended service life and resistance against extrusion.

- Good sealing performance as well as at low pressure
- Suitable for both rod and piston
- Economical solution
- Excellent wear-resistance
- Extended service life
- High resistance against extrusion
- Good temperature resistance
- Easy installation without expensive auxiliaries

## MATERIAL

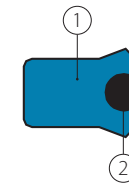

① **Type** Polyurethane  
**Designation** SEALPUR 93  
**Hardness** 93 °ShA

② **Type** Nitril Rubber NBR  
**Designation** RUBSEAL 70  
**Hardness** 70 °ShA

## FIELD OF APPLICATION

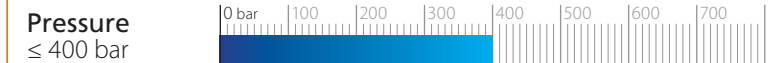

**Fluids** Hydraulic oils (mineral oil based)  
 For other fluids contact our technical department

## SURFACE ROUGHNESS

**Dynamic surface** Ra ≤ 0.3 µm Rt ≤ 2.5 µm  
**Static surface** Ra ≤ 1.6 µm Rt ≤ 6.3 µm

## GAP DIMENSION "g"

The largest gap dimension appearing in operation on the non-pressurised side:

50 bar	1.20 mm	300 bar	0.25 mm
100 bar	0.80 mm	400 bar	0.17 mm
200 bar	0.40 mm		

## LEAD-IN CHAMFERS

d	Smin
less 100	5 mm
100÷200	7 mm
over 200	10 mm

After mounting the seal in the housing, verify that the energizing element is positioned correctly.

To avoid damaging the sealing lips during installation, housing must have rounded chamfers. Sharp edges and burrs within the installation area of the seal must be removed.

The above data are maximum values, they may be maintained for short periods and can not be used at the same time simultaneously.

# UPN

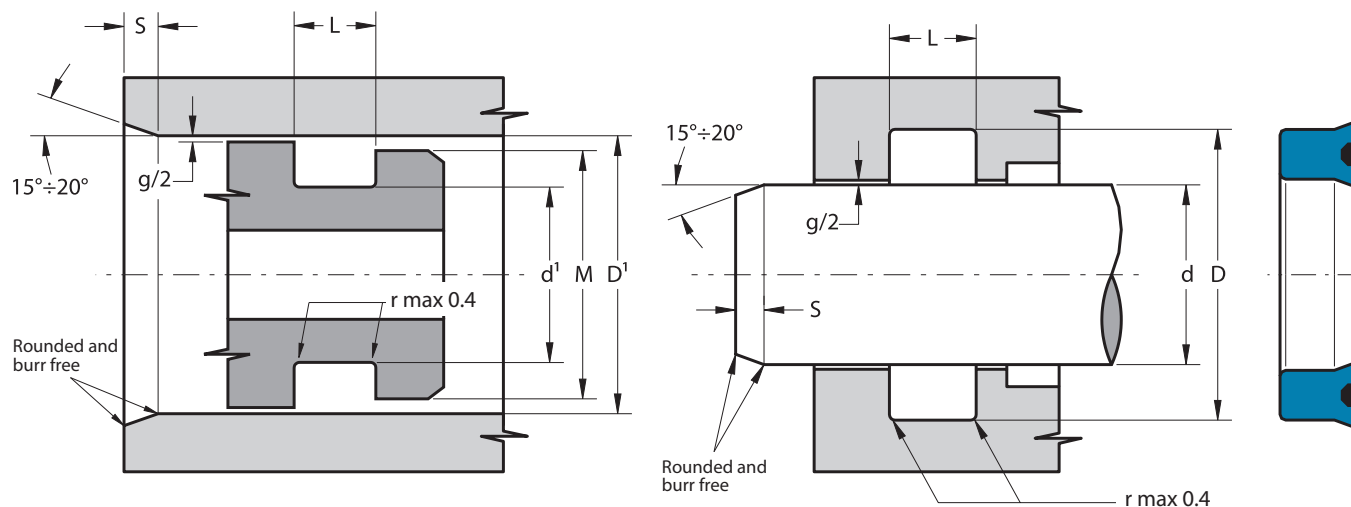

Part.	$d_{f7}^{1 f8}$	$D_{H10}^{1 H10}$	$L_{+0.25}$	M
UPN 5 17 9	5	17	10.0	14.0
UPN 8 18 9	8	18	10.0	15.5
UPN 10 18 5	10	18	6.0	16.0
UPN 10 20 8	10	20	9.0	17.5
UPN 10 22 8	10	22	9.0	19.0
UPN 12 22 5	12	22	6.0	19.5
UPN 12 22 7	12	22	8.0	19.5
UPN 12 22 8	12	22	9.0	19.5
UPN 12 24 8	12	24	9.0	21.0
UPN 14 24 8	14	24	9.0	21.5
UPN 14 27 7	14	27	8.0	24.0
UPN 15 21.5 4.5	15	21.5	5.0	20.0
UPN 15 25 8	15	25	9.0	22.5
UPN 15 25 10	15	25	11.0	22.5
UPN 16 24 8	16	24	9.0	22.0
UPN 16 26 5	16	26	6.0	23.5
UPN 16 26 8	16	26	9.0	23.5
UPN 16 28 6	16	28	7.0	25.0
UPN 16 28 9	16	28	10.0	25.0
UPN 16 32 8	16	32	9.0	28.0
UPN 17 25 4	17	25	4.5	23.0
UPN 17 25 6	17	25	7.0	23.0
UPN 17 27 6.5	17	27	7.5	24.5
UPN 18 28 8	18	28	9.0	25.5

Part.	$d_{f7}^{1 f8}$	$D_{H10}^{1 H10}$	$L_{+0.25}$	M
UPN 18 30 8	18	30	9.0	27.0
UPN 20 28 5.7	20	28	6.2	26.0
UPN 20 28 7	20	28	8.0	26.0
UPN 20 29 5	20	29	5.5	27.0
UPN 20 30 7	20	30	8.0	27.5
UPN 20 30 8	20	30	9.0	27.5
UPN 20 30 10	20	30	11.0	27.5
UPN 20 32 7.5	20	32	8.5	29.0
UPN 20 35 9	20	35	10.0	31.5
UPN 20 40 10	20	40	11.0	35.0
UPN 22 32 8	22	32	9.0	29.5
UPN 22 32 10	22	32	11.0	29.5
UPN 22 35 10	22	35	11.0	32.0
UPN 22 40 10	22	40	11.0	35.5
UPN 24 32 6	24	32	7.0	30.0
UPN 24 32 7	24	32	8.0	30.0
UPN 25 33 6	25	33	7.0	31.0
UPN 25 35 5	25	35	5.5	32.5
UPN 25 35 8	25	35	9.0	32.5
UPN 25 35 10	25	35	11.0	32.5
UPN 25 38 8	25	38	9.0	35.0
UPN 25 38 10	25	38	11.0	35.0
UPN 25 40 7	25	40	8.0	36.0
UPN 25 40 10	25	40	11.0	36.0

Part.	$d_{f7}^{1 f8}$	$D_{H10}^{1 H10}$	$L_{+0.25}$	M
UPN 27 36.5 6.8	27	36.5	7.8	34.0
UPN 28 38 7	28	38	8.0	35.5
UPN 28 38 8	28	38	9.0	35.5
UPN 28 38 10	28	38	11.0	35.5
UPN 28 40 10	28	40	11.0	37.0
UPN 30 40 5	30	40	5.5	37.5
UPN 30 40 6	30	40	7.0	37.5
UPN 30 40 10	30	40	11.0	37.5
UPN 30 42 9	30	42	10.0	39.0
UPN 30 42 10	30	42	11.0	39.0
UPN 30 45 10	30	45	11.0	41.5
UPN 30 50 10	30	50	11.0	45.0
UPN 30 50 12	30	50	13.0	45.0
UPN 32 40 5.5	32	40	6.0	38.0
UPN 32 40 8	32	40	9.0	38.0
UPN 32 42 10	32	42	11.0	39.5
UPN 32 45 10	32	45	11.0	42.0
UPN 34 45 7	34	45	8.0	42.5
UPN 34 45 9	34	45	10.0	42.5
UPN 35 43 6	35	43	7.0	41.0
UPN 35 45 5	35	45	5.5	42.5
UPN 35 45 6	35	45	7.0	42.5
UPN 35 45 7	35	45	8.0	42.5
UPN 35 45 8	35	45	9.0	42.5

# UPN

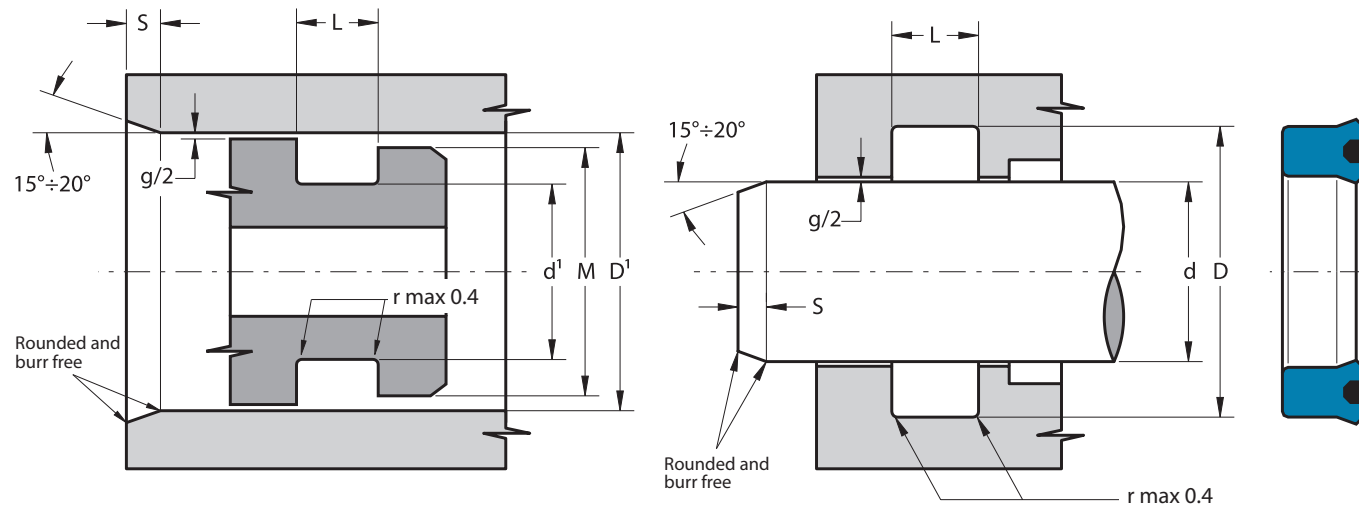

Part.	d <sup>1 f8</sup> d <sub>f7</sub>	D <sup>1 H10</sup> D <sub>H10</sub>	L <sup>+0.25</sup>	M
UPN 35 45 10	35	45	11.0	42.5
UPN 35 48 10	35	48	11.0	45.0
UPN 35 50 10	35	50	11.0	46.5
UPN 35 55 10	35	55	11.0	50.0
UPN 35 55 12	35	55	13.0	50.0
UPN 36 46 7	36	46	8.0	43.5
UPN 36 48 8	36	48	9.0	45.0
UPN 38 46 6.5	38	46	7.5	44.0
UPN 38 50 9	38	50	10.0	47.0
UPN 38 55 10	38	55	11.0	51.0
UPN 38 58 10	38	58	11.0	53.0
UPN 40 48 5.8	40	48	6.3	46.0
UPN 40 48 8	40	48	9.0	46.0
UPN 40 50 5	40	50	5.5	47.5
UPN 40 50 6	40	50	7.0	47.5
UPN 40 50 6.5	40	50	7.5	47.5
UPN 40 50 8	40	50	9.0	47.5
UPN 40 50 10	40	50	11.0	47.5
UPN 40 55 10	40	55	11.0	51.5
UPN 40 60 10	40	60	11.0	55.0
UPN 40 60 13	40	60	14.0	55.0
UPN 42 50 6	42	50	7.0	48.0
UPN 42 50 8	42	50	9.0	48.0
UPN 42 52 9	42	52	10.0	49.5

Part.	d <sup>1 f8</sup> d <sub>f7</sub>	D <sup>1 H10</sup> D <sub>H10</sub>	L <sup>+0.25</sup>	M
UPN 42 62 12	42	62	13.0	57.0
UPN 45 53 6.5	45	53	7.5	51.0
UPN 45 55 6	45	55	7.0	52.5
UPN 45 55 6.5	45	55	7.5	52.5
UPN 45 55 10	45	55	11.0	52.5
UPN 45 56 7	45	56	8.0	53.5
UPN 45 60 10	45	60	11.0	56.5
UPN 45 63 10	45	63	11.0	58.5
UPN 45 65 10	45	65	11.0	60.0
UPN 45 65 12	45	65	13.0	60.0
UPN 48 58 10	48	58	11.0	55.5
UPN 50 60 5	50	60	5.5	57.5
UPN 50 60 6	50	60	7.0	57.5
UPN 50 60 7	50	60	8.0	57.5
UPN 50 60 10	50	60	11.0	57.5
UPN 50 60 11	50	60	12.0	57.5
UPN 50 62 9	50	62	10.0	59.0
UPN 50 63 6	50	63	7.0	60.0
UPN 50 65 7	50	65	8.0	61.5
UPN 50 65 10	50	65	11.0	61.5
UPN 50 70 10	50	70	11.0	65.0
UPN 50 70 12	50	70	13.0	65.0
UPN 52 62 12	52	62	13.0	59.5
UPN 53 63 6.5	53	63	7.5	60.5

Part.	d <sup>1 f8</sup> d <sub>f7</sub>	D <sup>1 H10</sup> D <sub>H10</sub>	L <sup>+0.25</sup>	M
UPN 55 65 6	55	65	7.0	62.5
UPN 55 65 10	55	65	11.0	62.5
UPN 55 65 12	55	65	13.0	62.5
UPN 55 70 12	55	70	13.0	66.5
UPN 55 75 12	55	75	13.0	70.0
UPN 55 80 12	55	80	13.0	74.0
UPN 56 66 5	56	66	5.5	63.5
UPN 56 66 6	56	66	7.0	63.5
UPN 60 70 5	60	70	5.5	67.5
UPN 60 70 6	60	70	7.0	67.5
UPN 60 70 8	60	70	9.0	67.5
UPN 60 70 10	60	70	11.0	67.5
UPN 60 70 12	60	70	13.0	67.5
UPN 60 71 7	60	71	8.0	68.0
UPN 60 75 10	60	75	11.0	71.5
UPN 60 75 12	60	75	13.0	71.5
UPN 60 80 10	60	80	11.0	75.0
UPN 60 80 12	60	80	13.0	75.0
UPN 60 80 18	60	80	19.0	75.0
UPN 63 73 6	63	73	7.0	70.5
UPN 63 75 10	63	75	11.0	72.0
UPN 63 78 10	63	78	11.0	74.5
UPN 65 75 6	65	75	7.0	72.5
UPN 65 75 12	65	75	13.0	72.5

# UPN

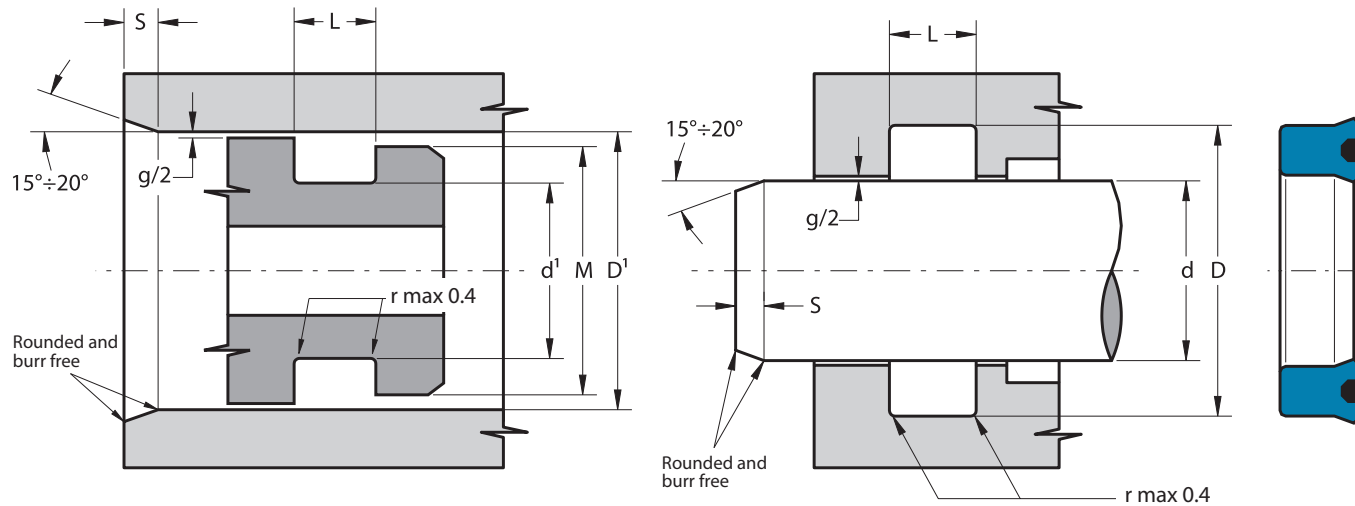

Part.	$d^{1\text{ f8}}$ $d^{1\text{ f7}}$	$D^{1\text{ H10}}$ $D^{1\text{ H10}}$	$L^{+0.25}$	M
UPN 65 80 10	65	80	11.0	76.5
UPN 65 80 11	65	80	12.0	76.5
UPN 65 80 12	65	80	13.0	76.5
UPN 65 85 12	65	85	13.0	80.0
UPN 67 77 10	67	77	11.0	74.5
UPN 68 92.4 14	68	92.4	15.0	86.5
UPN 70 75 3.5	70	75	4.1	73.5
UPN 70 80 5	70	80	6.0	77.5
UPN 70 80 6	70	80	7.0	77.5
UPN 70 80 8	70	80	9.0	77.5
UPN 70 80 10	70	80	11.0	77.5
UPN 70 80 12	70	80	13.0	77.5
UPN 70 85 11	70	85	12.0	81.5
UPN 70 85 12	70	85	13.0	81.5
UPN 70 90 12	70	90	13.0	85.0
UPN 75 85 6	75	85	7.0	82.5
UPN 75 85 12	75	85	13.0	82.5
UPN 75 90 7.5	75	90	8.5	86.5
UPN 75 90 10	75	90	11.0	86.5
UPN 75 90 12	75	90	13.0	86.5
UPN 75 95 10	75	95	11.0	90.0
UPN 75 95 12	75	95	13.0	90.0
UPN 75 95 13.5	75	95	14.5	90.0
UPN 75 95 14.5	75	95	15.5	90.0

Part.	$d^{1\text{ f8}}$ $d^{1\text{ f7}}$	$D^{1\text{ H10}}$ $D^{1\text{ H10}}$	$L^{+0.25}$	M
UPN 77.5 87.5 10	77.5	87.5	11.0	85.0
UPN 80 90 5	80	90	6.0	87.5
UPN 80 90 6	80	90	7.0	87.5
UPN 80 90 8	80	90	9.0	87.5
UPN 80 90 10	80	90	11.0	87.5
UPN 80 90 12	80	90	13.0	87.5
UPN 80 95 12	80	95	13.0	91.5
UPN 80 100 9.5	80	100	10.5	95.0
UPN 80 100 12	80	100	13.0	95.0
UPN 85 95 8.5	85	95	9.5	92.5
UPN 85 95 12	85	95	13.0	92.5
UPN 85 100 9	85	100	10.0	96.5
UPN 85 100 10	85	100	11.0	96.5
UPN 85 100 12	85	100	13.0	96.5
UPN 85 105 12	85	105	13.0	100.0
UPN 90 100 8	90	100	9.0	97.5
UPN 90 100 12	90	100	13.0	97.5
UPN 90 105 12	90	105	13.0	101.5
UPN 90 110 12	90	110	13.0	105.0
UPN 90 115 12	90	115	13.0	109.0
UPN 90 115 15	90	115	16.0	109.0
UPN 95 110 9	95	110	10.0	106.5
UPN 95 110 12	95	110	13.0	106.5
UPN 95 115 12	95	115	13.0	110.0

Part.	$d^{1\text{ f8}}$ $d^{1\text{ f7}}$	$D^{1\text{ H10}}$ $D^{1\text{ H10}}$	$L^{+0.25}$	M
UPN 100 115 9	100	115	10.0	111.5
UPN 100 115 12	100	115	13.0	111.5
UPN 100 120 12	100	120	13.0	115.0
UPN 100 125 12	100	125	13.0	119.0
UPN 100 125 15	100	125	16.0	119.0
UPN 105 120 8	105	120	9.0	116.5
UPN 105 120 15	105	120	16.0	116.5
UPN 105 125 12	105	125	13.0	120.0
UPN 105 125 15	105	125	16.0	120.0
UPN 110 125 9	110	125	10.0	121.5
UPN 110 125 12	110	125	13.0	121.5
UPN 110 125 15	110	125	16.0	121.5
UPN 110 130 15	110	130	16.0	125.0
UPN 115 135 15	115	135	16.0	130.0
UPN 120 140 15	120	140	16.0	135.0
UPN 125 140 9	125	140	10.0	136.5
UPN 125 140 11	125	140	12.0	136.5
UPN 125 140 15	125	140	16.0	136.5
UPN 125 145 15	125	145	16.0	140.0
UPN 130 145 12	130	145	13.0	141.5
UPN 130 150 15	130	150	16.0	145.0
UPN 140 155 9	140	155	10.0	151.5
UPN 140 160 12	140	160	13.0	155.0
UPN 140 160 15	140	160	16.0	155.0

# UPN

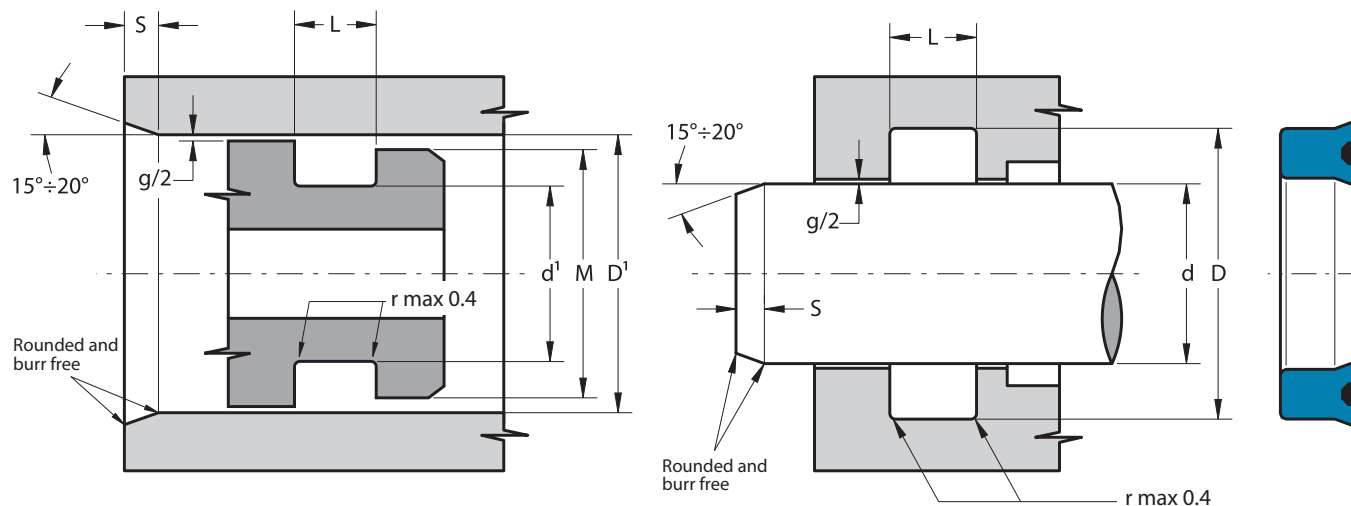

Part.	d <sup>1</sup> f <sub>8</sub> d f <sub>7</sub>	D <sup>1</sup> H <sub>10</sub> D H <sub>10</sub>	L +0.25	M
<b>UPN 145 165 15</b>	145	165	16.0	160.0
<b>UPN 150 170 15</b>	150	170	16.0	165.0
<b>UPN 160 175 12</b>	160	175	13.0	171.5
<b>UPN 160 180 15</b>	160	180	16.0	175.0
<b>UPN 170 190 12</b>	170	190	13.0	185.0
<b>UPN 170 190 15</b>	170	190	16.0	185.0
<b>UPN 175 200 15</b>	175	200	16.0	194.0
<b>UPN 180 200 15</b>	180	200	16.0	195.0
<b>UPN 180 205 18</b>	180	205	19.0	199.0
<b>UPN 190 210 15</b>	190	210	16.0	205.0
<b>UPN 200 220 12</b>	200	220	13.0	215.0
<b>UPN 200 220 15</b>	200	220	16.0	215.0
<b>UPN 200 225 18</b>	200	225	19.0	219.0
<b>UPN 220 250 18</b>	220	250	19.0	242.5

Part.	d <sup>1</sup> f <sub>8</sub> d f <sub>7</sub>	D <sup>1</sup> H <sub>10</sub> D H <sub>10</sub>	L +0.25	M
-------	---	---	---------	---

Inch sizes

<b>UPN 1500 2000 0250</b>	38.10	50.80	7.35	48.0
<b>UPN 2000 2500 0250</b>	50.80	63.50	7.35	60.5
<b>UPN 2000 2625 0562</b>	50.80	66.68	14.78	61.6
<b>UPN 2125 2625 0406</b>	53.97	66.68	11.00	63.5
<b>UPN 2250 2625 0375</b>	57.15	66.68	10.50	64.5
<b>UPN 2500 3250 0620</b>	63.50	82.55	16.75	78.0
<b>UPN 2625 3000 0187</b>	66.68	76.20	5.25	74.0
<b>UPN 3000 3625 0562</b>	76.20	92.08	14.78	87.1
<b>UPN 3000 3750 0620</b>	76.20	95.25	16.75	90.5
<b>UPN 3500 3875 0375</b>	88.90	98.43	10.50	96.0
<b>UPN 3500 4000 0375</b>	88.90	101.60	10.50	98.6
<b>UPN 3500 4250 0620</b>	88.90	107.95	16.75	103.0
<b>UPN 3875 4250 0187</b>	98.43	107.95	5.25	105.5
<b>UPN 5250 6000 0620</b>	133.36	152.40	16.75	147.5
<b>UPN 6250 7000 0620</b>	158.75	177.80	16.75	173.0
<b>UPN 6500 7500 0765</b>	165.10	190.50	20.40	184.0
<b>UPN 7000 8000 0750</b>	177.80	203.20	20.10	197.0





# OP



MATERIAL		
<b>Type</b>	<b>Designation</b>	<b>Hardness</b>
Polyurethane	SEALPUR 93	93 °ShA

### FIELD OF APPLICATION

<b>Pressure</b>	See table below		
<b>Speed</b>	Depending of working condition. It is preferable as static seal		
<b>Temperature</b>	<table border="1"> <tr> <td>-30°C ÷ +80°C</td> <td> </td> </tr> </table>	-30°C ÷ +80°C	
-30°C ÷ +80°C			
<b>Fluids</b>	Hydraulic oils (mineral oil based) For other fluids contact our technical department		

### GAP DIMENSION "g"

In order to avoid extrusion, the maximum pressure allowed depends on the fitting gap:

1.20 mm	50 bar	0.25 mm	300 bar
0.80 mm	100 bar	0.17 mm	400 bar
0.40 mm	200 bar	0.10 mm	500 bar

NB: for the Gap calculation, it is necessary to consider the elastic deformation of metal elements under pressure loads.

### SURFACE ROUGHNESS

<b>Housing surface</b>	Ra ≤ 0.8 µm	Rt ≤ 4.8 µm
------------------------	-------------	-------------

To avoid damaging the sealing lips during installation, housing must have rounded chamfers. Sharp edges and burrs within the installation area of the seal must be removed.

The above data are maximum values, they may be maintained for short periods and can not be used at the same time simultaneously.

The Aston Seals OP seal has been developed to be used as a valid alternative of the O-Ring for heavy duty applications to avoid the extrusion and damage of it that normally occurs in the presence of large gaps or high pressure.

It is a static (preferable) seal energized by pressure and can work as a single or double acting sealing element. The radial sealing forces, which guarantee good sealing performance, increase when the pressure rises.

Thanks to its elasticity, it can be installed very easily in a short time and without any auxiliaries.

The material used to produce this seal is

a polyurethane compound that ensures excellent properties on wear-resistance, extended service life and resistance against extrusion

- High resistance against extrusion
- Resistance to twisting
- Single and double acting
- Simple groove design
- Stability at pulsating pressure
- Extended service life
- Easy installation without expensive auxiliaries

# OP

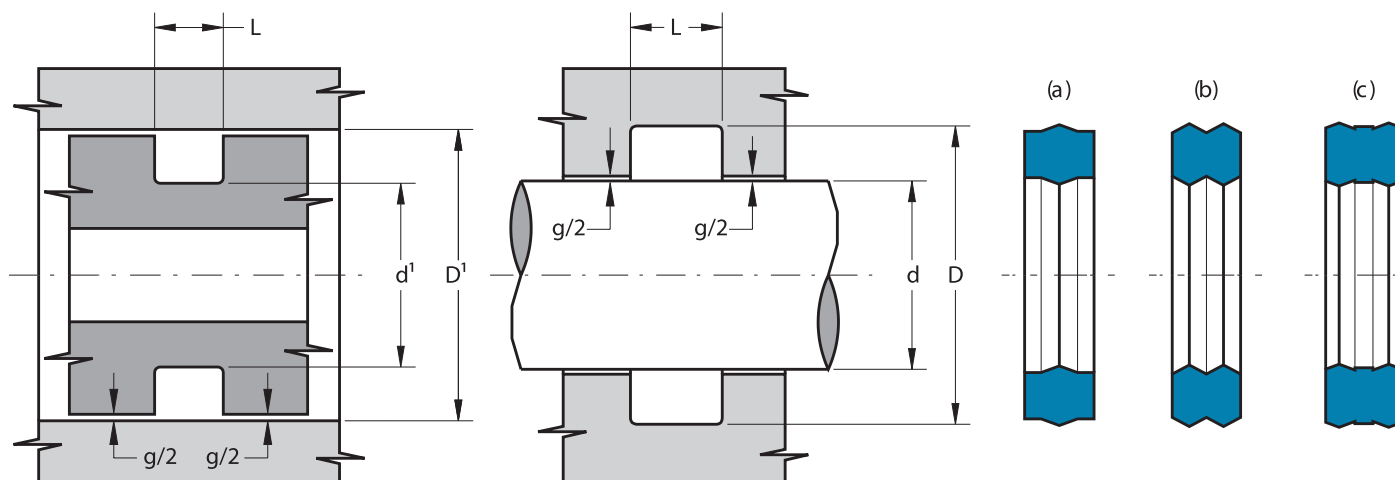

Part.	d <sup>f7</sup>	D <sup>H9</sup>	d <sup>1h9</sup>	D <sup>1H8</sup>	L <sup>+0.2</sup>	Tp.
OP 008	4.5	7.6	4.9	8	2.5	(a)
OP 009	5	8.1	5.9	9	2.5	(a)
OP 012	9	12.1	9.9	13	2.5	(a)
OP 013	11	14.1	10.9	14	2.5	(a)
OP 014	13	16.1	12.9	16	2.5	(a)
OP 014/A	-	-	13.07	15.93	3.5	(b)
OP 015	14	17.1	14.9	18	2.5	(a)
OP 015/A	-	-	14.67	17.53	3.5	(b)
OP 016	16	19.1	15.9	19	2.5	(a)
OP 016/A	-	-	16.25	19.12	3.5	(b)
OP 020/A	-	-	23.1	26	3.5	(b)
OP 023	27	30.1	26.9	30	2.5	(a)
OP 031	44	47.1	44.9	48	2.5	(a)
OP 034	54	57.1	54.9	58	2.5	(a)
OP 109	8	12.5	8.5	13	3.5	(b)
OP 113	14	18.5	14.5	19	3.5	(b)
OP 115	17	21.5	17.5	22	3.5	(b)
OP 116/A	19	23.6	-	-	5.5	(b)
OP 117	20	24.5	20.5	25	3.5	(b)
OP 118/813	22	26.5	22.5	27	3.5	(b)
OP 119	24	28.5	24.5	29	3.5	(b)
OP 120	25	29.5	25.5	30	3.5	(b)
OP 121	28	32.5	27.5	32	3.5	(b)
OP 123	30	34.5	30.5	35	3.5	(b)

Part.	d <sup>f7</sup>	D <sup>H9</sup>	d <sup>1h9</sup>	D <sup>1H8</sup>	L <sup>+0.2</sup>	Tp.
OP 126	35	39.5	35.5	40	3.5	(b)
OP 132	44	48.5	44.5	49	3.5	(b)
OP 133	46	50.5	46.5	51	3.5	(b)
OP 138	54	58.5	54.5	59	3.5	(b)
OP 138/A	54	58.5	54.5	59	5.0	(b)
OP 140/A	57	61.5	57.5	62	5.0	(b)
OP 142/A	60	64.5	60.5	65	5.0	(b)
OP 147	68	72.5	68.5	73	3.5	(b)
OP 153	89	93.5	89.5	94	3.5	(b)
OP 156	108	112.5	108.5	113	3.5	(b)
OP 209	17	23.2	17.8	24	4.5	(b)
OP 210	19	25.2	19.8	26	4.5	(b)
OP 211	20	26.2	21.8	28	4.5	(b)
OP 216	28	34.2	28.8	35	4.5	(b)
OP 216/A	28	34.3	-	-	6.5	(b)
OP 217	30	36.2	30.8	37	4.5	(b)
OP 217/A	30	36.3	-	-	6.5	(b)
OP 218	31	37.2	31.8	38	4.5	(b)
OP 219	33	39.2	33.8	40	4.5	(b)
OP 220	35	41.2	35.8	42	4.5	(b)
OP 225/829	48	54.2	47.8	54	4.5	(b)
OP 227/833	54	60.2	54.8	61	4.5	(b)
OP 230	64	70.2	63.8	70	4.5	(b)
OP 233	73	79.2	73.8	80	4.5	(b)

Part.	d <sup>f7</sup>	D <sup>H9</sup>	d <sup>1h9</sup>	D <sup>1H8</sup>	L <sup>+0.2</sup>	Tp.
OP 233/845/A	73	79.2	73.8	80	6.5	(c)
OP 234	76	82.2	76.8	83	4.5	(b)
OP 235	79	85.2	79.8	86	4.5	(b)
OP 236	82	88.2	82.8	89	4.5	(b)
OP 238	89	95.2	88.8	95	4.5	(b)
OP 239	92	98.2	92.8	99	4.5	(b)
OP 240/A	95	101.2	95.8	102	6.5	(b)
OP 242/A	-	-	101.5	107.8	6.1	(c)
OP 247	117	123.2	117.8	124	4.5	(b)
OP 256	146	152.2	145.8	152	4.5	(b)
OP 326/A	41	50.4	42.6	52	9.5	(c)
OP 335/A	69	78.4	70.6	80	9.5	(c)
OP 337/A	76	85.4	76.6	86	9.5	(c)
OP 340/A	85	94.4	85.6	95	9.5	(c)
OP 342/A	92	101.4	92.6	102	9.5	(c)
OP 346/A	104	113.4	105.6	115	9.5	(c)
OP 349/A	114	123.4	115.6	125	9.5	(c)
OP 350/A	117	126.4	118.6	128	9.5	(c)
OP 430	130	142.2	130.8	143	9.5	(c)
OP 614	12	16.8	-	-	3.5	(b)
OP 616	15	19.5	15.5	20	3.5	(b)
OP 617	18	22.8	-	-	3.5	(b)
OP 620	80	89.4	80.6	90	7.0	(c)
OP 621	90	99.4	90.6	100	7.0	(c)

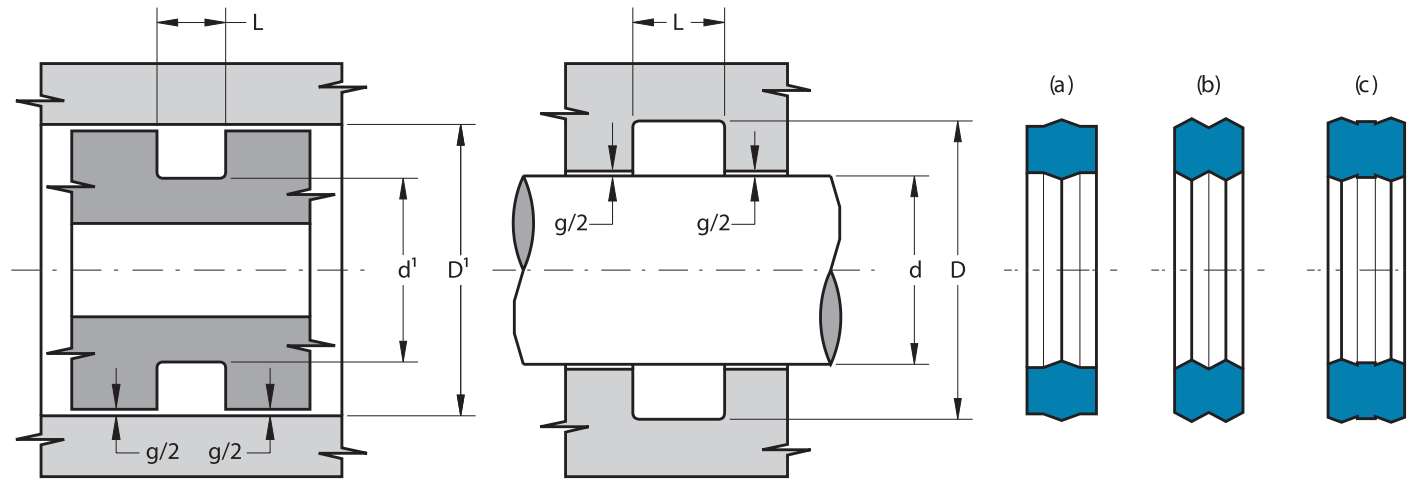

Part.	d <sup>f7</sup>	D <sup>H9</sup>	d <sup>1 h9</sup>	D <sup>1 H8</sup>	L <sup>+0.2</sup>	Tp.
<b>OP 621/A</b>	90	99.4	90.6	100	9.5	(c)
<b>OP 623/A</b>	110	119.4	110.6	120	9.5	(c)
<b>OP 674</b>	210	222.2	209.8	222	9.5	(c)
<b>OP 806</b>	11	14.1	11.9	15	2.5	(a)
<b>OP 806/A</b>	-	-	12.1	15	3.5	(b)
<b>OP 812</b>	21	25.5	21.5	26	3.5	(b)
<b>OP 824</b>	40	46.2	39.8	46	4.5	(b)
<b>OP 826</b>	43	49.2	43.8	50	4.5	(b)
<b>OP 832</b>	52	58.2	53.8	60	4.5	(b)
<b>OP 834</b>	56	62.2	55.8	62	4.5	(b)
<b>OP 835</b>	57	63.2	57.8	64	4.5	(b)
<b>OP 836</b>	59	65.2	58.8	65	4.5	(b)
<b>OP 836/A</b>	59	65.2	58.8	65	6.5	(c)
<b>OP 839</b>	64	70.2	63.8	70	4.5	(b)
<b>OP 842</b>	68	74.2	68.8	75	4.5	(b)
<b>OP 845</b>	73	79.2	73.8	80	4.5	(b)

Part.	d <sup>f7</sup>	D <sup>H8</sup>	L <sup>+0.2</sup>	Tp.
-------	-----------------	-----------------	-------------------	-----

- Metric range -

<b>OP 9 11.5 2.1</b>	9	11.5	2.5	(a)
<b>OP 9.25 12 2.5</b>	9.25	12	3.0	(a)
<b>OP 10 14.4 3</b>	10	14.4	3.5	(b)
<b>OP 12 16.6 2.6</b>	12	16.6	3.1	(b)
<b>OP 12 18 6</b>	12	18	7.0	(b)
<b>OP 12.8 17.15 2.64</b>	12.8	17.15	3.14	(b)
<b>OP 14 30 12</b>	14	30	13.0	(b)
<b>OP 16 20 3</b>	16	20	3.5	(b)
<b>OP 16 30 7.5</b>	16	30	8.5	(b)
<b>OP 16 30 10</b>	16	30	11.0	(b)
<b>OP 17 22 4</b>	17	22	4.5	(b)
<b>OP 18.7 21.5 3</b>	18.7	21.5	3.5	(b)
<b>OP 19.9 22.5 3</b>	19.9	22.5	3.5	(b)
<b>OP 23 28 4.5</b>	23	28	5.0	(b)
<b>OP 25.4 30 4.9</b>	25.4	30	5.4	(b)
<b>OP 26.6 35 5.5</b>	26.6	35	6.5	(b)
<b>OP 27.5 33.6 4</b>	27.5	33.6	4.5	(b)
<b>OP 28.4 32.6 3</b>	28.4	32.6	3.6	(b)
<b>OP 29 34 4</b>	29	34	4.5	(b)
<b>OP 33.2 36 3.2</b>	33.2	36	3.6	(b)
<b>OP 33.2 36 4.25</b>	33.2	36	4.75	(b)

Part.	d <sup>f7</sup>	D <sup>H8</sup>	L <sup>+0.2</sup>	Tp.
<b>OP 34.6 40.55 5</b>	34.6	40.55	5.5	(b)
<b>OP 34.6 40.7 4</b>	34.6	40.7	4.5	(b)
<b>OP 35.1 40.6 4</b>	35.1	40.6	4.6	(b)
<b>OP 35.1 41 5.5</b>	35.1	41	6.5	(b)
<b>OP 35.2 38 4.25</b>	35.2	38	4.75	(b)
<b>OP 35.2 40 4.9</b>	35.2	40	5.4	(b)
<b>OP 39 45.2 4</b>	39	45.2	4.5	(b)
<b>OP 40 45 4.9</b>	40	45	5.4	(b)
<b>OP 42.6 48 5.7</b>	42.6	48	6.7	(b)
<b>OP 44.6 50 5.2</b>	44.6	50	6.2	(b)
<b>OP 45.4 50 4.9</b>	45.4	50	5.4	(b)
<b>OP 45.5 50.5 3.5</b>	45.5	50.5	4.0	(b)
<b>OP 47.5 52 3</b>	47.5	52	3.5	(b)
<b>OP 50.5 55 3</b>	50.5	55	3.5	(b)
<b>OP 52.2 57 3.5</b>	52.2	57	4.0	(b)
<b>OP 53.8 63 8.7</b>	53.8	63	9.7	(c)
<b>OP 56 61 4</b>	56	61	4.5	(b)
<b>OP 57.6 63 5.2</b>	57.6	63	6.2	(b)
<b>OP 58.4 63 4.9</b>	58.4	63	5.4	(b)
<b>OP 60.5 65 3</b>	60.5	65	3.5	(b)
<b>OP 61.4 66 3.5</b>	61.4	66	4.0	(b)
<b>OP 61.5 66 3</b>	61.5	66	3.5	(b)
<b>OP 64.3 70 5.7</b>	64.3	70	6.7	(b)
<b>OP 69.4 75 4.8</b>	69.4	75	5.3	(b)

# OP

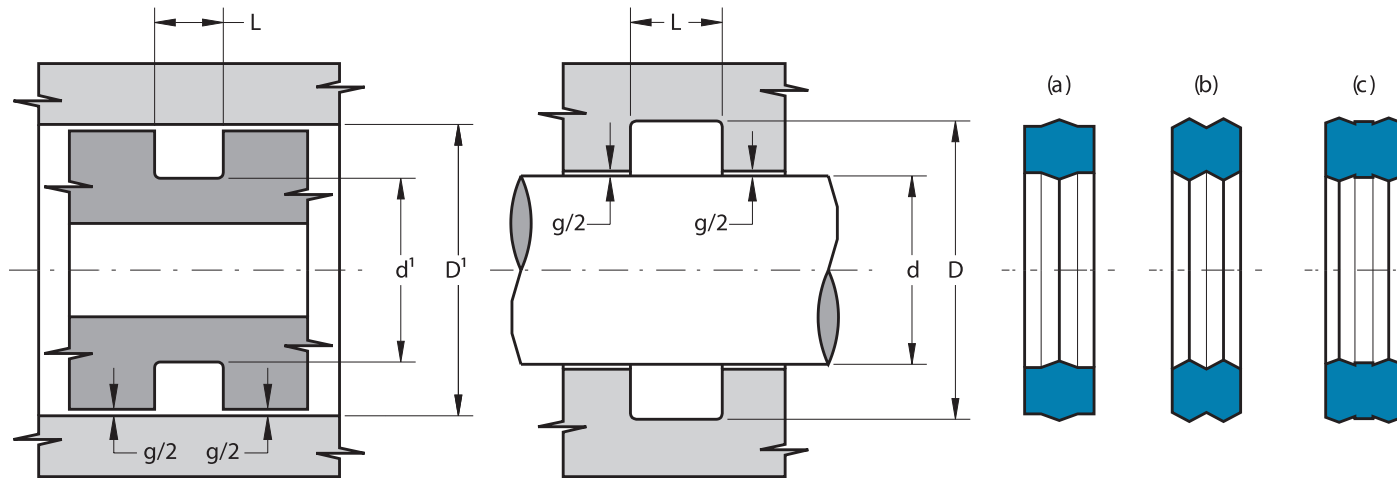

Part.	d <sup>f7</sup>	D <sup>H8</sup>	L <sup>+0.2</sup>	Tp.
<b>OP 70 75.6 5.2</b>	70	75.6	6.2	(b)
<b>OP 73 78 4</b>	73	78	4.5	(b)
<b>OP 73 81 5.6</b>	73	81	6.6	(b)
<b>OP 73.6 80 5.4</b>	73.6	80	6.4	(b)
<b>OP 73.8 80 5.9</b>	73.8	80	6.9	(c)
<b>OP 74.4 80 4.8</b>	74.4	80	5.3	(b)
<b>OP 74.5 80 4</b>	74.5	80	4.5	(b)
<b>OP 78.5 83 3</b>	78.5	83	3.5	(b)
<b>OP 78.9 85.2 5.5</b>	78.9	85.2	6.0	(b)
<b>OP 79.3 85 5.7</b>	79.3	85	6.7	(b)
<b>OP 84.3 90 5.7</b>	84.3	90	6.7	(b)
<b>OP 85.5 90.5 4.5</b>	85.5	90.5	5.0	(b)
<b>OP 88 96 5.6</b>	88	96	6.6	(b)
<b>OP 90.8 100 8.7</b>	90.8	100	9.7	(c)
<b>OP 91.4 100 8</b>	91.4	100	9.0	(c)
<b>OP 93.8 100 5.9</b>	93.8	100	6.9	(c)
<b>OP 96 101 4.5</b>	96	101	5.0	(b)
<b>OP 101 106 4.5</b>	101	106	5.0	(b)
<b>OP 101.4 110 8</b>	101.4	110	9.0	(c)

Part.	d <sup>f7</sup>	D <sup>H8</sup>	L <sup>+0.2</sup>	Tp.
<b>OP 101.7 111 7.5</b>	101.7	111	8.5	(c)
<b>OP 103 111 5.6</b>	103	111	6.6	(b)
<b>OP 105 111 5.5</b>	105	111	6.5	(b)
<b>OP 106.2 112 5.1</b>	106.2	112	6.0	(c)
<b>OP 106.7 116 7.5</b>	106.7	116	8.5	(c)
<b>OP 107.2 113 5.1</b>	107.2	113	6.0	(c)
<b>OP 110 116 5.5</b>	110	116	6.5	(b)
<b>OP 115.5 120.25 3.7</b>	115.5	120.25	4.2	(b)
<b>OP 118 126 5.6</b>	118	126	6.6	(b)
<b>OP 125.2 131 5.1</b>	125.2	131	6.0	(c)
<b>OP 129.2 135 5.1</b>	129.2	135	6.0	(c)
<b>OP 131.6 140 7.6</b>	131.6	140	8.6	(c)
<b>OP 132.8 145 8.5</b>	132.8	145	9.5	(c)
<b>OP 134 140.3 5</b>	134	140.3	6.0	(b)
<b>OP 140.2 146 4</b>	140.2	146	4.5	(b)
<b>OP 143 152 8.1</b>	143	152	9.1	(c)
<b>OP 144 155.5 9.5</b>	144	155.5	10.5	(c)
<b>OP 145 151 5</b>	145	151	6.0	(c)
<b>OP 148.4 160 11.3</b>	148.4	160	12.3	(c)

Part.	d <sup>f7</sup>	D <sup>H8</sup>	L <sup>+0.2</sup>	Tp.
<b>OP 155.1 163.5 7.5</b>	155.1	163.5	8.5	(b)
<b>OP 160.2 166 4</b>	160.2	166	4.5	(b)
<b>OP 165 171 5</b>	165	171	6.0	(c)
<b>OP 165.8 175 8.8</b>	165.8	175	9.8	(b)
<b>OP 166.4 175 8.1</b>	166.4	175	9.1	(c)
<b>OP 168 179.5 9.5</b>	168	179.5	10.5	(c)
<b>OP 185 191 5</b>	185	191	6.0	(c)
<b>OP 185.8 195 8.9</b>	185.8	195	9.9	(b)
<b>OP 188.4 200 11.3</b>	188.4	200	12.3	(c)
<b>OP 192 198 5</b>	192	198	6.0	(c)
<b>OP 196.4 205 8</b>	196.4	205	9.0	(b)
<b>OP 207 213 5</b>	207	213	6.0	(c)
<b>OP 217.4 229 11</b>	217.4	229	12.0	(c)
<b>OP 231 244 7.5</b>	231	244	8.5	(c)
<b>OP 233.5 240.5 8</b>	233.5	240.5	9.0	(c)
<b>OP 262 272 8.5</b>	262	272	9.5	(c)
<b>OP 293 303 8.5</b>	293	303	9.5	(c)

# HP

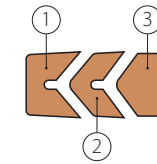

- ① Reinforced cotton fabric impregnated with nitrile rubber
- ② Reinforced cotton fabric impregnated with nitrile rubber and/or nitrile elastomer
- ③ Reinforced cotton fabric impregnated with nitrile rubber

### FIELD OF APPLICATION

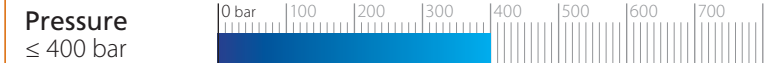

**Fluids** Hydraulic oils (mineral oil based)  
For other fluids contact our technical department

### SURFACE ROUGHNESS

<b>Dynamic surface</b>	Ra ≤ 0.2 μm	Rt ≤ 2.5 μm
<b>Static surface</b>	Ra ≤ 0.8 μm	Rt ≤ 6.3 μm

### GAP DIMENSION "g"

The largest gap dimension appearing in operation on the non-pressurised side:

0.30 mm

### LEAD-IN CHAMFERS

d	Smin
less 100	5 mm
100÷200	7 mm
over 200	10 mm

To avoid damaging the sealing lips during installation, housing must have rounded chamfers. Sharp edges and burrs within the installation area of the seal must be removed.

The above data are maximum values, they may be maintained for short periods and can not be used at the same time simultaneously.

The seal type Aston Seals HP is designed for sealing rods, pistons and plungers in hydraulic cylinders and hydraulic presses. Extremely suitable for medium to heavy duty applications, it is composed of:

- a "U" Base Ring which supports the center rings from getting extruded. Sometimes an anti-extrusion ring can be incorporated to increase the maximum working pressure
- The center "V" rings are the main sealing elements being sensitive to fluid pressure variations assuring good sealing performances in all conditions
- The pressure ring helps in retaining the center ring profile and distributing pressure equally

(\*) In low pressure conditions, it is recommended that at least one unreinforced nitrile elastomer "V" ring is incorporated in the packing seal.

- Extended service life
- Simple groove design
- Good sealing performance as well as at low pressure (\*)
- Can be optimally adjusted to the application
- Good mechanical stability at high temperature
- Excellent wear-resistance

# HP

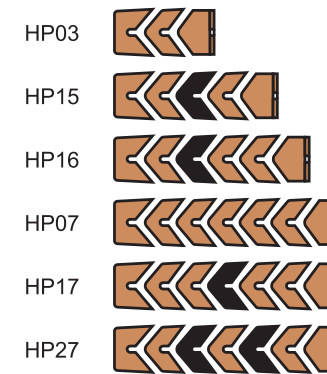
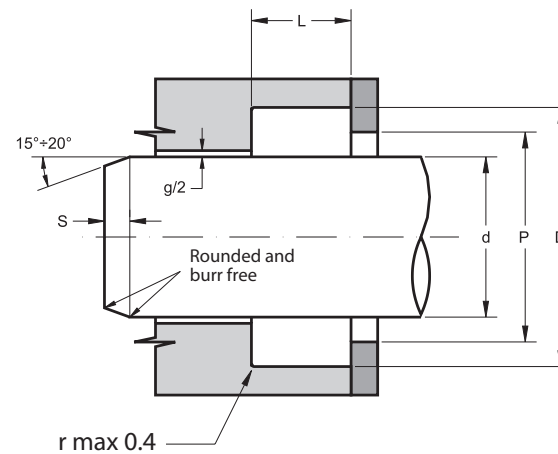
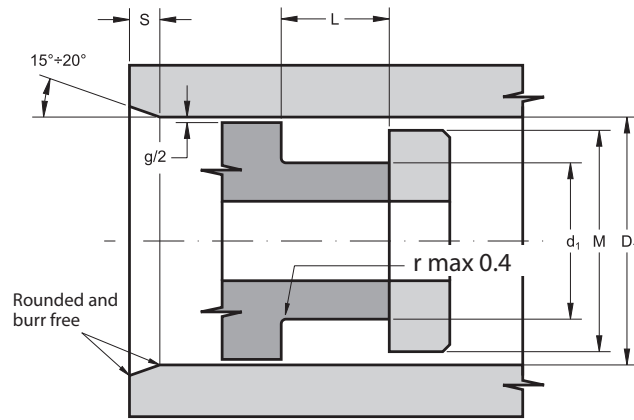

Part.	$d^{1 f8}$ $d^{f7}$	$D^{1 H10}$ $D^{H10}$	$L^{+0.25}$	M	P
HP15 8 18 13.5	8	18	14	17	9
HP27 8 18 18.5	8	18	19.5	17	9
HP15 10 18 14.7	10	18	15.2	17	11
HP27 10 18 19.7	10	18	20.7	17	11
HP03 10 20 8.9	10	20	9.3	19	11
HP15 10 20 13.5	10	20	14	19	11
HP27 10 20 18.5	10	20	19.5	19	11
HP15 10 22 18.4	10	22	18.9	21	11
HP27 10 22 22	10	22	23	21	11
HP03 12 22 8.9	12	22	9.3	21	13
HP15 12 22 13.5	12	22	14	21	13
HP27 12 22 18.5	12	22	19.5	21	13
HP05 12 24 21	12	24	21.5	23	13
HP07 12 24 27	12	24	28	23	13
HP15 12 25 14	12	25	14.5	24	13
HP27 12 25 19	12	25	20	24	13
HP05 12.7 25.4 18	12.7	25.4	18.5	24.4	13.7
HP07 12.7 25.4 24	12.7	25.4	25	24.4	13.7
HP15 14 24 13.5	14	24	14	23	15
HP27 14 24 18.5	14	24	19.5	23	15
HP05 14 26 15.2	14	26	15.7	25	15
HP07 14 26 20.2	14	26	21.2	25	15
HP03 15 25 8.9	15	25	9.3	24	16
HP15 15 25 13.5	15	25	14	24	16

Part.	$d^{1 f8}$ $d^{f7}$	$D^{1 H10}$ $D^{H10}$	$L^{+0.25}$	M	P
HP27 15 25 18.5	15	25	19.5	24	16
HP05 15 27 16	15	27	16.5	26	16
HP07 15 27 22	15	27	23	26	16
HP15 16 26 13.5	16	26	14	25	17
HP27 16 26 18.5	16	26	19.5	25	17
HP05 16 28 17	16	28	17.8	27	17
HP07 16 28 23.7	16	28	24.7	27	17
HP05 16 32 28.5	16	32	29.2	31	17
HP07 16 32 37.5	16	32	38.5	31	17
HP03 18 28 8.9	18	28	9.3	27	19
HP15 18 28 13.5	18	28	14	27	19
HP27 18 28 18.5	18	28	19.5	27	19
HP05 18 30 18.5	18	30	19	29	19
HP07 18 30 25.5	18	30	26.5	29	19
HP05 18 32 21	18	32	21.5	31	19
HP07 18 32 29	18	32	30	31	19
HP05 18.2 28.5 15.5	18.2	28.5	16	27.5	19.2
HP07 18.2 28.5 20.5	18.2	28.5	21.5	27.5	19.2
HP03 20 30 8.9	20	30	9.3	29	21
HP27 20 30 18.5	20	30	19.5	29	21
HP15 20 30 21	20	30	21.5	29	21
HP03 20 32 10.4	20	32	10.9	31	21
HP15 20 32 16.5	20	32	17	31	21
HP27 20 32 22.5	20	32	23.5	31	21

Part.	$d^{1 f8}$ $d^{f7}$	$D^{1 H10}$ $D^{H10}$	$L^{+0.25}$	M	P
HP05 20 35 19.5	20	35	20.2	34	21
HP07 20 35 26.5	20	35	27.5	34	21
HP05 20 36 23	20	36	23.7	35	21
HP07 20 36 30	20	36	31	35	21
HP05 20 40 30	20	40	31.7	39	21
HP07 20 40 40	20	40	41	39	21
HP15 22 32 18	22	32	18.5	31	23
HP27 22 32 18.5	22	32	19.5	31	23
HP15 22 34 16.5	22	34	17	33	23
HP27 22 34 22.5	22	34	23.5	33	23
HP05 22 36 21.5	22	36	22	35	23
HP07 22 36 28.5	22	36	29.5	35	23
HP05 22 42 26	22	42	26.7	41	23
HP07 22 42 36	22	42	37	41	23
HP05 22.1 38.1 24	22.1	38.1	24.7	37.1	23.1
HP07 22.1 38.1 32	22.1	38.1	33	37.1	23.1
HP03 24 36 10.4	24	36	10.9	35	25
HP05 24 36 16.5	24	36	17	35	25
HP07 24 36 22.5	24	36	23.5	35	25
HP05 24 40 29	24	40	29.7	39	25
HP07 24 40 38	24	40	39	39	25
HP05 25 35 17	25	35	18	34	26
HP07 25 35 23	25	35	24	34	26
HP05 25 37 16.5	25	37	17	36	26

# HP

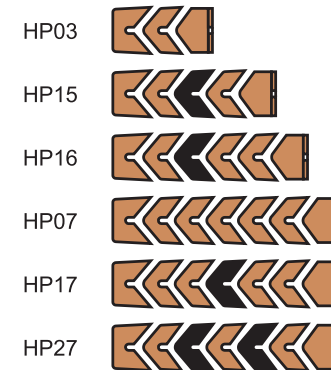
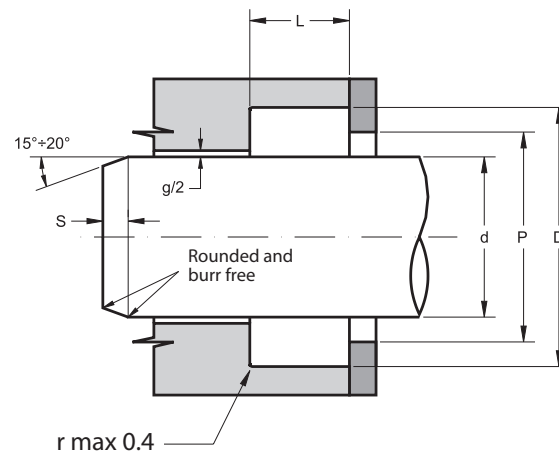
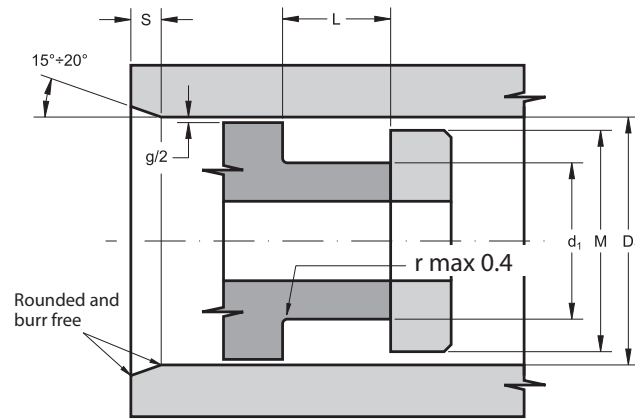

Part.	d <sup>1 f8</sup> d <sup>1 f7</sup>	D <sup>1 H10</sup> D <sup>H10</sup>	L <sup>+0.25</sup>	M	P
HP15 25 37 16.5	25	37	17	36	26
HP27 25 37 22.5	25	37	23.5	36	26
HP05 25 38 20.5	25	38	21	37	26
HP07 25 38 27.5	25	38	28.5	37	26
HP03 25 40 11	25	40	11.5	39	26
HP15 25 40 19	25	40	19.7	39	26
HP27 25 40 22.5	25	40	23.5	39	26
HP15 25 42 24	25	42	25.2	41	26
HP27 25 42 32	25	42	33	41	26
HP05 25 45 25	25	45	26	44	26
HP07 25 45 35	25	45	36.2	44	26
HP15 28 40 16.5	28	40	17.5	39	29
HP27 28 40 22.5	28	40	23.5	39	29
HP15 28 43 16.5	28	43	17.5	42	29
HP27 28 43 22.5	28	43	23.5	42	29
HP05 28 44 17	28	44	17.7	43	29
HP07 28 44 23	28	44	24	43	29
HP05 30 40 20.8	30	40	21.8	39	31
HP07 30 40 28	30	40	29	39	31
HP15 30 42 16.5	30	42	17	41	31
HP27 30 42 22.5	30	42	23.5	41	31
HP03 30 45 11	30	45	11.5	44	31
HP15 30 45 16.5	30	45	17.5	44	31
HP27 30 45 22.5	30	45	23.7	44	31

Part.	d <sup>1 f8</sup> d <sup>1 f7</sup>	D <sup>1 H10</sup> D <sup>H10</sup>	L <sup>+0.25</sup>	M	P
HP05 30 46 29	30	46	29.7	45	31
HP07 30 46 37	30	46	38	45	31
HP05 30 50 28	30	50	29	49	31
HP07 30 50 38	30	50	39.2	49	31
HP05 32 42 17	32	42	17.5	41	33
HP07 32 42 23	32	42	24	41	33
HP15 32 44 16.5	32	44	17	43	33
HP27 32 44 22.5	32	44	23.5	43	33
HP05 32 45 20.5	32	45	21	44	33
HP07 32 45 27.5	32	45	28.5	44	33
HP15 32 47 16.5	32	47	17.5	46	33
HP27 32 47 22.5	32	47	23.7	46	33
HP05 32 48 17	32	48	18	47	33
HP07 32 48 23	32	48	24.2	47	33
HP05 32 52 31	32	52	31.7	51	33
HP07 32 52 41	32	52	42	51	33
HP05 35 45 21	35	45	22	44	36
HP07 35 45 28	35	45	29	44	36
HP15 35 47 16.5	35	47	17.5	46	36
HP27 35 47 22.5	35	47	23.7	46	36
HP05 35 48 19.5	35	48	20.2	47	36
HP07 35 48 26.5	35	48	27.5	47	36
HP03 35 50 11	35	50	11.5	49	36
HP05 35 50 22	35	50	23	49	36

Part.	d <sup>1 f8</sup> d <sup>1 f7</sup>	D <sup>1 H10</sup> D <sup>H10</sup>	L <sup>+0.25</sup>	M	P
HP27 35 50 22.5	35	50	23.7	49	36
HP05 35 55 35.5	35	55	36.5	54	36
HP07 35 55 46.5	35	55	47.7	54	36
HP15 36 48 16.5	36	48	17.5	47	37
HP27 36 48 22.5	36	48	23.7	47	37
HP15 36 51 16.5	36	51	17.2	50	37
HP27 36 51 22.5	36	51	23.7	50	37
HP05 36 52 17	36	52	17.7	51	37
HP07 36 52 23	36	52	24.2	51	37
HP05 38 55 27	38	55	28	54	39
HP07 38 55 37	38	55	38.2	54	39
HP15 40 50 17	40	50	17.5	49	41
HP07 40 50 33	40	50	34	49	41
HP15 40 52 16.5	40	52	17.5	51	41
HP27 40 52 22.5	40	52	23.5	51	41
HP03 40 55 11	40	55	11.5	54	41
HP05 40 55 22	40	55	22.7	54	41
HP27 40 55 22.5	40	55	23.7	54	41
HP15 40 60 30	40	60	30.7	59	41
HP27 40 60 40	40	60	41.2	59	41
HP05 40 65 34	40	65	35.2	64	41
HP07 40 65 46	40	65	47.4	64	41
HP15 42 54 16.5	42	54	17.5	53	43
HP27 42 54 22.5	42	54	23.5	53	43



# HP

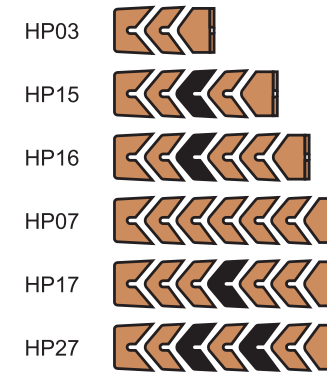
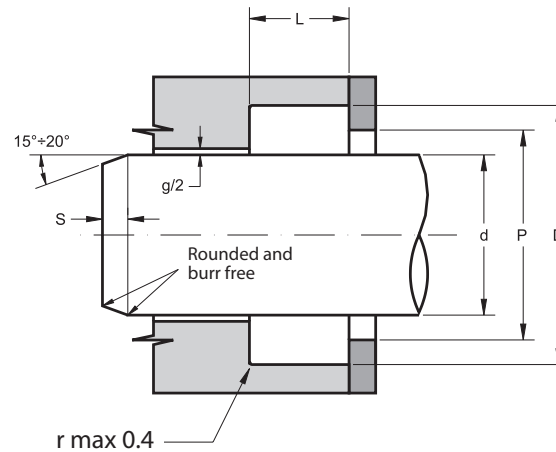
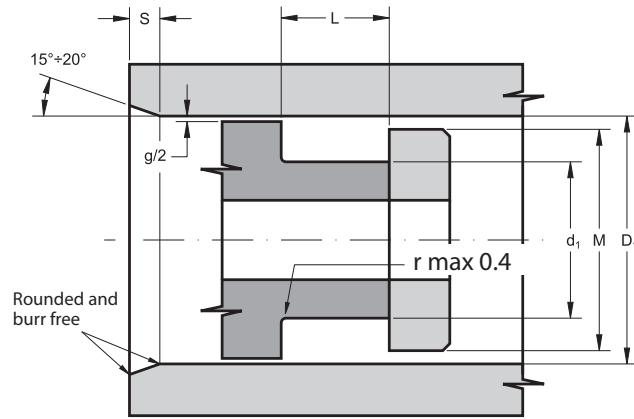

Part.	$d^{1/18}$ $d_{f7}$	$D^{1/10}$ $D_{H10}$	$L^{+0.25}$	M	P
HP15 42 57 16.5	42	57	17.5	56	43
HP27 42 57 22.5	42	57	23.7	56	43
HP05 42 58 29	42	58	30	57	43
HP07 42 58 38	42	58	39.2	57	43
HP05 45 55 17	45	55	18	54	46
HP07 45 55 22.6	45	55	23.6	54	46
HP03 45 60 11	45	60	11.5	59	46
HP15 45 60 22	45	60	22.7	59	46
HP27 45 60 22.5	45	60	23.7	59	46
HP05 45 61 29	45	61	30	60	46
HP07 45 61 37	45	61	38.2	60	46
HP15 45 65 27	45	65	28	64	46
HP27 45 65 27.5	45	65	28.7	64	46
HP05 48 60 24	48	60	25	59	49
HP07 48 60 32	48	60	33.2	59	49
HP05 48 62 21	48	62	22	61	49
HP07 48 62 29	48	62	30.2	61	49
HP03 48 63 12.5	48	63	13	62	49
HP05 48 63 22.5	48	63	23.2	62	49
HP07 48 63 30.5	48	63	31.5	62	49
HP27 50 65 22.5	50	65	23.7	64	51
HP15 50 65 23.6	50	65	24.6	64	51
HP05 50 66 29	50	66	30	65	51
HP07 50 66 37	50	66	38.2	65	51

Part.	$d^{1/18}$ $d_{f7}$	$D^{1/10}$ $D_{H10}$	$L^{+0.25}$	M	P
HP03 50 70 14.6	50	70	15.2	69	51
HP05 50 70 29	50	70	30	69	51
HP27 50 70 30	50	70	31.2	69	51
HP05 50 75 32	50	75	33	74	51
HP07 50 75 44	50	75	45.2	74	51
HP15 50.8 63.5 19	50.8	63.5	19.7	62.5	51.8
HP27 50.8 63.5 25	50.8	63.5	26	62.5	51.8
HP05 50.8 66.7 23	50.8	66.7	23.7	65.7	51.8
HP07 50.8 66.7 31	50.8	66.7	32	65.7	51.8
HP05 52 72 36	52	72	37	71	53
HP07 52 72 40	52	72	41.2	71	53
HP05 55 67 25	55	67	25.5	66	56
HP07 55 67 34	55	67	35	66	56
HP27 55 70 22.5	55	70	23.7	69	56
HP05 55 70 26	55	70	26.7	69	56
HP15 55 75 29	55	75	30	74	56
HP27 55 75 30	55	75	31.2	74	56
HP15 56 71 16.5	56	71	17.2	70	57
HP27 56 71 22.5	56	71	23.7	70	57
HP05 56 76 21.5	56	76	22.2	75	57
HP05 56 76 32.5	56	76	33.5	75	57
HP05 56 76 35	56	76	36	75	57
HP07 56 76 37	56	76	38.2	75	57
HP05 57.2 76.2 31	57.2	76.2	32	75.2	58.2

Part.	$d^{1/18}$ $d_{f7}$	$D^{1/10}$ $D_{H10}$	$L^{+0.25}$	M	P
HP07 57.2 76.2 41	57.2	76.2	42.2	75.2	58.2
HP15 60 75 18.5	60	75	19.2	74	61
HP27 60 75 22.5	60	75	23.7	74	61
HP05 60 76 28	60	76	29	75	61
HP07 60 76 37	60	76	38.2	75	61
HP03 60 80 14.6	60	80	15.2	79	61
HP15 60 80 31	60	80	32	79	61
HP27 60 80 37	60	80	38.2	79	61
HP15 63 78 16.5	63	78	17.5	77	64
HP27 63 78 22.5	63	78	23.7	77	64
HP15 63 80 26.5	63	80	27.2	79	64
HP05 63 83 21.5	63	83	22.5	82	64
HP27 63 83 37	63	83	38.2	82	64
HP05 63 85 31	63	85	32	84	64
HP07 63 85 41	63	85	42.2	84	64
HP05 63.5 79.3 24	63.5	79.3	25	78.3	64.5
HP07 63.5 79.3 32	63.5	79.3	33.2	78.3	64.5
HP15 63.5 82.6 25.5	63.5	82.6	26.5	81.6	64.5
HP27 63.5 82.6 34.5	63.5	82.6	35.7	81.6	64.5
HP15 65 80 16.5	65	80	17.5	79	66
HP27 65 80 22.5	65	80	23.7	79	66
HP15 65 85 28	65	85	29	84	66
HP27 65 85 40	65	85	41.2	84	66
HP27 70 85 22.5	70	85	23.7	84	71

# HP

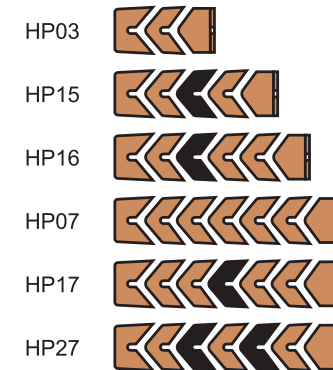
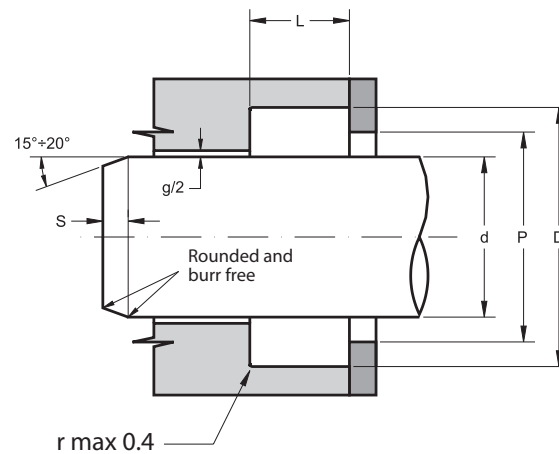
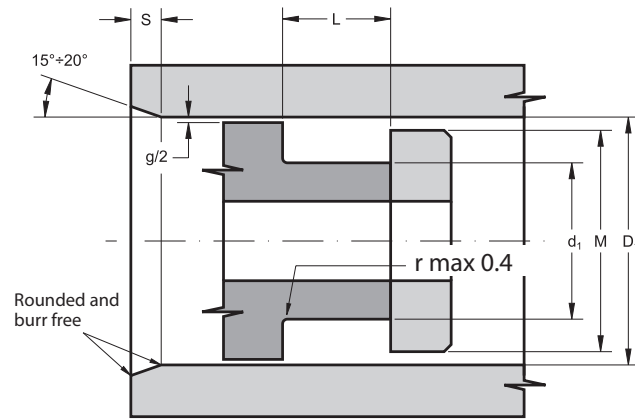

Part.	d <sup>1 f8</sup> d <sup>1 f7</sup>	D <sup>1 H10</sup> D <sup>H10</sup>	L <sup>+0.25</sup>	M	P
HP05 70 85 27	70	85	28	84	71
HP15 70 89 23	70	89	23.7	88	71
HP27 70 89 31	70	89	32	88	71
HP03 70 90 20.6	70	90	21.2	89	71
HP15 70 90 21.5	70	90	22.5	89	71
HP15 70 90 29	70	90	30	89	71
HP27 70 90 40	70	90	41.2	89	71
HP05 75 90 22	75	90	23	89	76
HP27 75 90 22.5	75	90	23.7	89	76
HP15 75 95 30	75	95	31	94	76
HP27 75 95 40	75	95	41.2	94	76
HP05 75 100 29	75	100	30	99	76
HP07 75 100 50	75	100	51.4	99	76
HP05 75 105 40	75	105	41	104	76
HP07 75 105 54	75	105	55.4	104	76
HP15 76.2 95.2 29	76.2	95.2	30	94.2	77.2
HP27 76.2 95.2 39	76.2	95.2	40.2	94.2	77.2
HP05 76.2 101.6 38	76.2	101.6	39	100.6	77.2
HP07 76.2 101.6 50	76.2	101.6	51.4	100.6	77.2
HP15 80 95 16.5	80	95	17.5	94	81
HP27 80 95 22.5	80	95	23.7	94	81
HP03 80 100 20.6	80	100	21.2	99	81
HP15 80 100 29	80	100	30	99	81
HP27 80 100 40	80	100	41.2	99	81

Part.	d <sup>1 f8</sup> d <sup>1 f7</sup>	D <sup>1 H10</sup> D <sup>H10</sup>	L <sup>+0.25</sup>	M	P
HP05 80 105 26.5	80	105	27.5	104	81
HP07 80 105 50.5	80	105	51.9	104	81
HP05 82.5 101.6 28	82.5	101.6	29	100.6	83.5
HP07 82.5 101.6 38	82.5	101.6	39.2	100.6	83.5
HP15 85 100 16.5	85	100	17.3	99	86
HP27 85 100 22.5	85	100	23.7	99	86
HP15 85 105 30	85	105	31	104	86
HP27 85 105 40	85	105	41.2	104	86
HP05 85 110 33	85	110	34	109	86
HP07 85 110 45	85	110	46.2	109	86
HP05 88.9 114.3 39.1	88.9	114.3	40	113.3	89.9
HP07 88.9 114.3 50.5	88.9	114.3	52	113.3	89.9
HP05 89 105 25	89	105	26	104	90
HP07 89 105 33	89	105	34.2	104	90
HP27 90 105 22.5	90	105	23.7	104	91
HP05 90 105 31	90	105	32	104	91
HP03 90 110 20.6	90	110	21.2	109	91
HP05 90 110 26	90	110	27	109	91
HP17 90 110 40	90	110	41.2	109	91
HP15 90 115 27	90	115	28	114	91
HP27 90 115 45.5	90	115	46.9	114	91
HP05 90 120 40.5	90	120	41.5	119	91
HP07 90 120 55.5	90	120	56.9	119	91
HP15 95 110 23	95	110	24	109	96

Part.	d <sup>1 f8</sup> d <sup>1 f7</sup>	D <sup>1 H10</sup> D <sup>H10</sup>	L <sup>+0.25</sup>	M	P
HP07 95 110 36.5	95	110	37.9	109	96
HP03 95 115 20.6	95	115	21.2	114	96
HP05 95 115 30	95	115	31	114	96
HP07 95 115 40	95	115	41.2	114	96
HP05 95 120 38	95	120	39	119	96
HP07 95 120 50	95	120	51	119	96
HP05 95.3 114.3 25	95.3	114.3	26	113.3	96.3
HP07 95.3 114.3 33	95.3	114.3	34.2	113.3	96.3
HP15 100 115 24	100	115	25	114	101
HP27 100 115 30	100	115	31.2	114	101
HP15 100 120 27	100	120	28	119	101
HP17 100 120 40	100	120	41.2	119	101
HP03 100 125 25	100	125	25.8	124	101
HP05 100 125 27	100	125	28	124	101
HP17 100 125 49	100	125	50.4	124	101
HP05 100 130 43.5	100	130	44.5	129	101
HP07 100 130 58.5	100	130	60	129	101
HP05 101.6 120.7 26	101.6	120.7	26.7	119.7	102.6
HP05 101.6 120.7 35	101.6	120.7	36	119.7	102.6
HP15 105 120 24	105	120	25	119	106
HP27 105 120 32	105	120	33.2	119	106
HP15 105 125 29	105	125	30	124	106
HP27 105 125 39.5	105	125	40.9	124	106
HP05 105 130 33	105	130	34	129	106

# HP

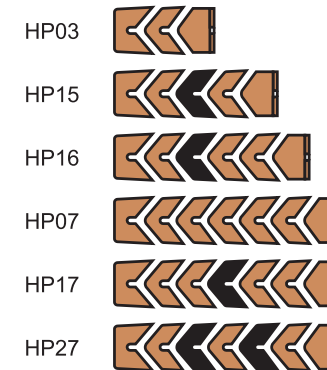
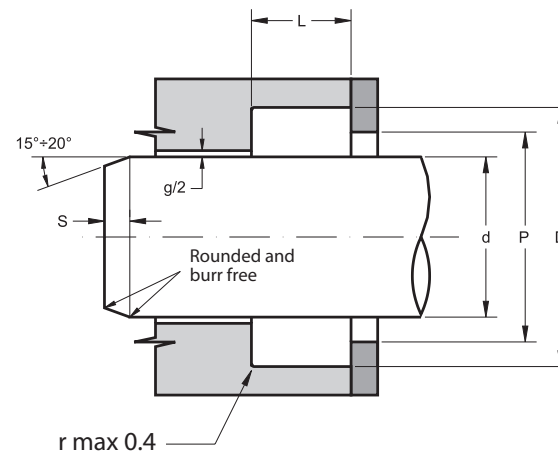
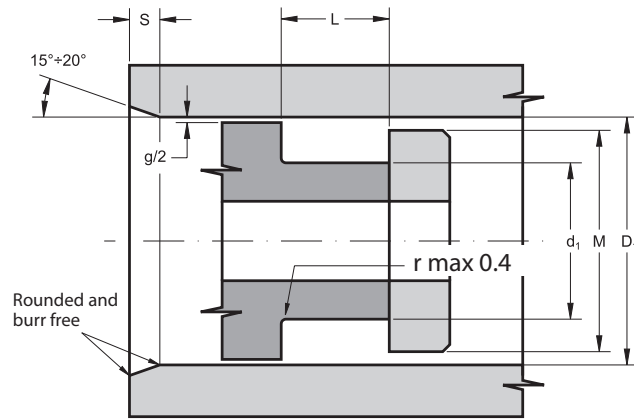

Part.	$d^{1 f8}$ $d^{f7}$	$D^{1 H10}$ $D^{H10}$	$L^{+0.25}$	M	P
HP07 105 130 45	105	130	46.4	129	106
HP05 105 135 34	105	135	35	134	106
HP07 105 135 54	105	135	55.4	134	106
HP15 110 125 22	110	125	23	124	111
HP27 110 125 30	110	125	31.2	124	111
HP15 110 130 30	110	130	31	129	111
HP17 110 130 40	110	130	41.2	129	111
HP15 110 132 36	110	132	37	131	111
HP27 110 132 48	110	132	49.2	131	111
HP05 110 135 42.5	110	135	43.5	134	111
HP07 110 135 45	110	135	46.4	134	111
HP05 114 130 25	114	130	26	129	115
HP07 114 130 33	114	130	34	129	115
HP15 115 130 22	115	130	23	129	116
HP27 115 130 30	115	130	31.2	129	116
HP03 115 140 25	115	140	25.8	139	116
HP15 115 140 37	115	140	38	139	116
HP17 115 140 46	115	140	47.4	139	116
HP05 115 145 43	115	145	44	144	116
HP07 115 145 57	115	145	58.4	144	116
HP15 120 140 30	120	140	31	139	121
HP27 120 140 40	120	140	41.2	139	121
HP05 120 145 33.5	120	145	34.5	144	121
HP07 120 145 45.5	120	145	46.9	144	121

Part.	$d^{1 f8}$ $d^{f7}$	$D^{1 H10}$ $D^{H10}$	$L^{+0.25}$	M	P
HP03 120 150 28	120	150	29	149	121
HP05 120 150 40	120	150	41	149	121
HP07 120 150 52.5	120	150	54	149	121
HP15 125 140 26	125	140	27	139	126
HP27 125 140 34	125	140	35.2	139	126
HP05 125 145 30	125	145	31	144	126
HP07 125 145 40	125	145	41.2	144	126
HP15 125 150 27	125	150	28	149	126
HP17 125 150 46	125	150	47.4	149	126
HP05 125 155 40	125	155	41	154	126
HP07 125 155 54	125	155	55.4	154	126
HP05 130 145 25.5	130	145	26.2	144	131
HP07 130 145 33.5	130	145	34.5	144	131
HP15 130 150 29.5	130	150	30.5	149	131
HP27 130 150 39.5	130	150	40.9	149	131
HP05 130 155 36	130	155	37	154	131
HP07 130 155 48	130	155	49.4	154	131
HP03 130 160 28	130	160	29	159	131
HP05 130 160 40	130	160	41	159	131
HP07 130 160 60	130	160	61.4	159	131
HP05 135 155 30	135	155	31	154	136
HP07 135 155 40	135	155	41.2	154	136
HP05 135 160 37.5	135	160	38.5	159	136
HP07 135 160 49.5	135	160	50.9	159	136

Part.	$d^{1 f8}$ $d^{f7}$	$D^{1 H10}$ $D^{H10}$	$L^{+0.25}$	M	P
HP15 140 155 26	140	155	27	154	141
HP27 140 155 34	140	155	35.2	154	141
HP15 140 160 28	140	160	29	159	141
HP27 140 160 38	140	160	39.2	159	141
HP05 140 165 41	140	165	42	164	141
HP17 140 165 46	140	165	47.4	164	141
HP05 140 170 38	140	170	39	169	141
HP07 140 170 60	140	170	61.4	169	141
HP15 145 165 30	145	165	31	164	146
HP27 145 165 40	145	165	41.4	164	146
HP05 145 170 35.5	145	170	36.5	169	146
HP07 145 170 48.5	145	170	49.9	169	146
HP15 150 170 30	150	170	31	169	151
HP27 150 170 40	150	170	41.2	169	151
HP05 150 175 38.5	150	175	39.5	174	151
HP07 150 175 51.5	150	175	52.9	174	151
HP03 150 180 30.5	150	180	31.5	179	151
HP05 150 180 39	150	180	40	179	151
HP07 150 180 60	150	180	61.4	179	151
HP15 160 180 30	160	180	31	179	161
HP27 160 180 40	160	180	41.2	179	161
HP05 160 190 32	160	190	33	189	161
HP07 160 190 60	160	190	61.4	189	161
HP15 170 190 30	170	190	31	189	171

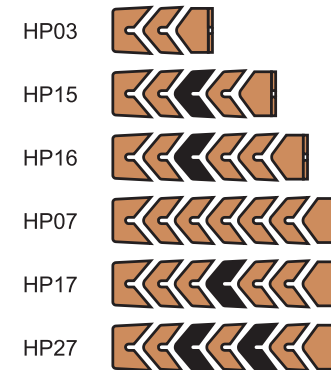
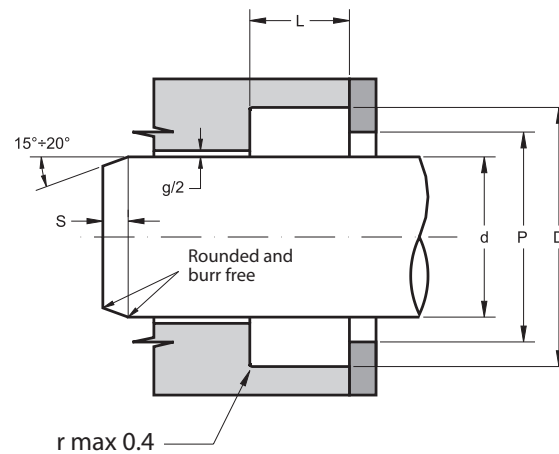
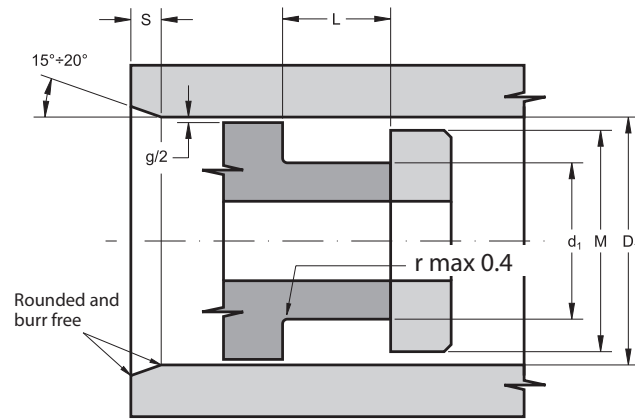

Part.	d <sup>1 f8</sup> d <sup>1 f7</sup>	D <sup>1 H10</sup> D <sup>H10</sup>	L <sup>+0.25</sup>	M	P
HP27 170 190 40	170	190	41.2	189	171
HP05 170 195 35	170	195	36	194	171
HP07 170 195 46	170	195	47.4	194	171
HP03 170 200 32.5	170	200	33.5	199	171
HP05 170 200 40	170	200	41	199	171
HP07 170 200 60	170	200	61.4	199	171
HP05 175 200 42	175	200	43	199	176
HP07 175 200 55	175	200	56.4	199	176
HP15 180 200 30	180	200	31	199	181
HP27 180 200 40	180	200	41.2	199	181
HP05 180 210 40	180	210	41	209	181
HP07 180 210 60	180	210	61.4	209	181
HP05 180 220 60	180	220	61	219	181
HP07 180 220 80	180	220	81.5	219	181
HP05 185 215 41.5	185	215	42.5	214	186
HP07 185 215 56.5	185	215	57.9	214	186
HP05 187.3 200 21	187.3	200	22	199	188.3
HP07 187.3 200 28	187.3	200	29.2	199	188.3
HP05 190 220 41.5	190	220	42.5	219	191
HP07 190 220 56.5	190	220	58	219	191
HP15 195 215 35	195	215	36	214	196
HP27 195 215 45	195	215	46.2	214	196
HP03 195 225 32.5	195	225	33.5	224	196
HP05 195 225 40	195	225	41	224	196

Part.	d <sup>1 f8</sup> d <sup>1 f7</sup>	D <sup>1 H10</sup> D <sup>H10</sup>	L <sup>+0.25</sup>	M	P
HP07 195 225 54	195	225	55.4	224	196
HP15 200 220 30	200	220	31	219	201
HP27 200 220 40	200	220	41.2	219	201
HP15 200 225 35	200	225	36	224	201
HP27 200 225 47	200	225	48.4	224	201
HP05 200 230 45	200	230	46	229	201
HP07 200 230 60	200	230	61.4	229	201
HP05 210 240 41.5	210	240	42.5	239	211
HP07 210 240 56.5	210	240	58	239	211
HP05 215 245 50.5	215	245	51.5	244	216
HP07 215 245 65.5	215	245	67	244	216
HP05 220 240 30	220	240	31	239	221
HP07 220 240 40	220	240	41.2	239	221
HP03 220 250 32.5	220	250	33.5	249	221
HP05 220 250 51	220	250	52	249	221
HP07 220 250 62.5	220	250	64	249	221
HP05 220 260 50	220	260	51	259	221
HP07 220 260 66	220	260	67.5	259	221
HP05 228.6 254 38	228.6	254	39	253	229.6
HP07 228.6 254 50	228.6	254	51.4	253	229.6
HP05 230 260 43.5	230	260	44.5	259	231
HP07 230 260 58.5	230	260	60	259	231
HP05 230 270 51	230	270	52	269	231
HP07 230 270 69	230	270	70.5	269	231

Part.	d <sup>1 f8</sup> d <sup>1 f7</sup>	D <sup>1 H10</sup> D <sup>H10</sup>	L <sup>+0.25</sup>	M	P
HP05 240 260 30	240	260	31	259	241
HP07 240 260 40	240	260	41.2	259	241
HP05 240 270 40	240	270	41	269	241
HP07 240 270 54	240	270	55.5	269	241
HP05 240 280 51	240	280	52	279	241
HP07 240 280 69	240	280	70.5	279	241
HP15 250 270 30	250	270	31	269	251
HP27 250 270 40	250	270	41.2	269	251
HP05 250 280 32.5	250	280	33.5	279	251
HP07 250 280 59.5	250	280	61	279	251
HP05 250 290 51.5	250	290	52.5	289	251
HP07 250 290 68.5	250	290	70	289	251
HP05 260 280 30	260	280	31	279	261
HP07 260 280 40	260	280	41.2	279	261
HP05 260 290 45	260	290	46	289	261
HP07 260 290 60	260	290	61.5	289	261
HP05 260 300 48	260	300	49	299	261
HP07 260 300 64	260	300	65.5	299	261
HP05 270 300 45	270	300	46	299	271
HP07 270 300 60	270	300	61.5	299	271
HP05 270 310 49	270	310	50	309	271
HP07 270 310 67	270	310	68.5	309	271
HP05 275 305 49.5	275	305	50.5	304	276
HP07 275 305 65.5	275	305	67	304	276

# HP

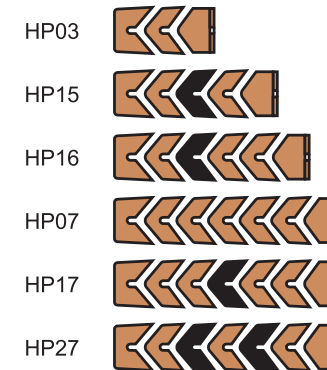
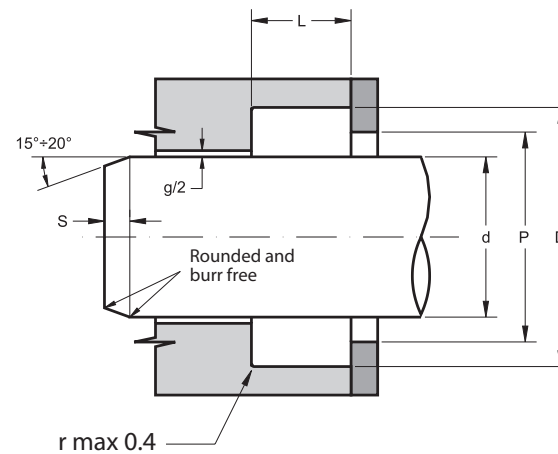
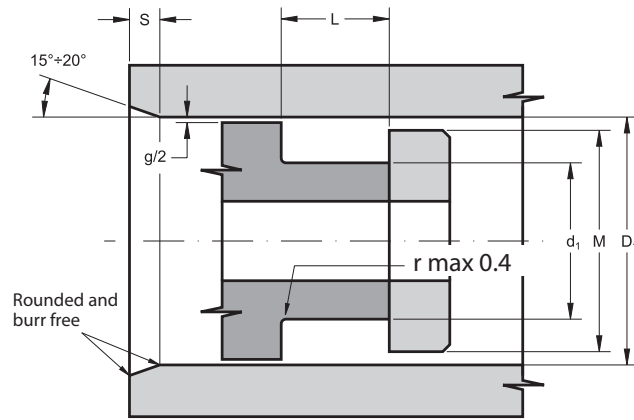

Part.	$d_{f7}^{+18}$ $d_{f7}$	$D_{H10}^{+18}$ $D_{H10}$	$L^{+0.25}$	M	P
HP05 280 310 42	280	310	43	309	281
HP07 280 310 56	280	310	57.5	309	281
HP05 280 320 49.5	280	320	50.5	319	281
HP07 280 320 66.5	280	320	68	319	281
HP05 290 320 50.5	290	320	51.5	319	291
HP07 290 320 55.5	290	320	57	319	291
HP05 300 320 32	300	320	33	319	301
HP07 300 320 42	300	320	43.2	319	301
HP05 300 330 45	300	330	46	329	301
HP07 300 330 60	300	330	61.5	329	301
HP05 300 340 53	300	340	54	339	301
HP07 300 340 72	300	340	73.5	339	301
HP15 310 330 32	310	330	33	329	311
HP27 310 330 43	310	330	44.2	329	311
HP05 310 340 43.5	310	340	44.5	339	311
HP07 310 340 58.5	310	340	60	339	311
HP05 310 350 50	310	350	51	349	311
HP07 310 350 68	310	350	69.5	349	311
HP05 315 345 45	315	345	46	344	316
HP07 315 345 60	315	345	61.5	344	316
HP05 320 350 41	320	350	42	349	321
HP07 320 350 55	320	350	56.5	349	321
HP05 320 360 53.5	320	360	54.5	359	321
HP07 320 360 71.5	320	360	73	359	321

Part.	$d_{f7}^{+18}$ $d_{f7}$	$D_{H10}^{+18}$ $D_{H10}$	$L^{+0.25}$	M	P
HP05 320 370 68	320	370	69.5	369	321
HP07 320 370 92	320	370	94	369	321
HP05 330 360 50.5	330	360	51.5	359	331
HP07 330 360 65.5	330	360	67	359	331
HP05 330 370 57	330	370	58.5	369	331
HP07 330 370 75	330	370	77	369	331
HP05 340 370 46	340	370	47	369	341
HP07 340 370 61	340	370	62.5	369	341
HP05 340 375 52	340	375	53	374	341
HP07 340 375 70	340	375	71.5	374	341
HP05 340 380 49.5	340	380	50.5	379	341
HP07 340 380 66.5	340	380	68	379	341
HP05 350 380 40	350	380	41	379	351
HP07 350 380 52.5	350	380	53.5	379	351
HP05 350 390 54	350	390	55	389	351
HP07 350 390 74	350	390	75.5	389	351
HP05 360 390 40.5	360	390	41.5	389	361
HP07 360 390 55.5	360	390	57	389	361
HP05 360 400 52	360	400	53	399	361
HP07 360 400 70	360	400	71.5	399	361
HP05 370 390 33	370	390	34	389	371
HP07 370 390 45	370	390	46.2	389	371
HP05 370 400 41	370	400	42	399	371
HP07 370 400 55	370	400	56.5	399	371

Part.	$d_{f7}^{+18}$ $d_{f7}$	$D_{H10}^{+18}$ $D_{H10}$	$L^{+0.25}$	M	P
HP05 380 410 42	380	410	43	409	381
HP07 380 410 58	380	410	59.5	409	381
HP05 380 420 60	380	420	61	419	381
HP07 380 420 80	380	420	81.5	419	381
HP05 390 420 50.5	390	420	51.5	419	391
HP07 390 420 65.5	390	420	67	419	391
HP05 390 430 55	390	430	56	429	391
HP07 390 430 73	390	430	74.5	429	391
HP05 400 440 50.5	400	440	51.5	439	401
HP07 400 440 67.5	400	440	69	439	401
HP05 410 450 59	410	450	60	449	411
HP07 410 450 79	410	450	80.5	449	411
HP05 415 460 65	415	460	66.5	459	416
HP07 415 460 87	415	460	89	459	416
HP05 420 450 44	420	450	45	449	421
HP07 420 450 58	420	450	59.5	449	421
HP05 420 460 53	420	460	54	459	421
HP07 420 460 71	420	460	72.5	459	421
HP05 430 470 56	430	470	57	469	431
HP07 430 470 76	430	470	77.5	469	431
HP15 440 470 50.5	440	470	51.5	469	441
HP27 440 470 65.5	440	470	67	469	441
HP05 440 480 52	440	480	53	479	441
HP07 440 480 70	440	480	71.5	479	441

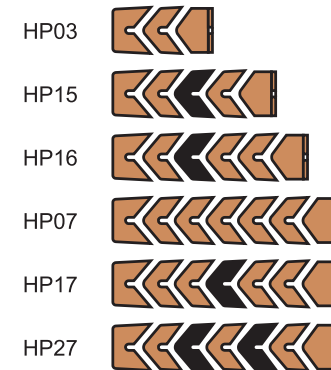
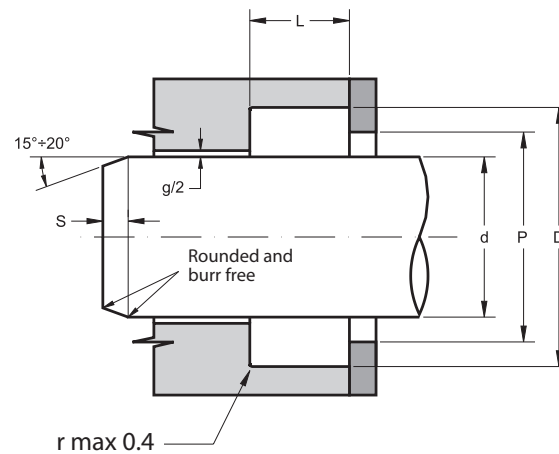
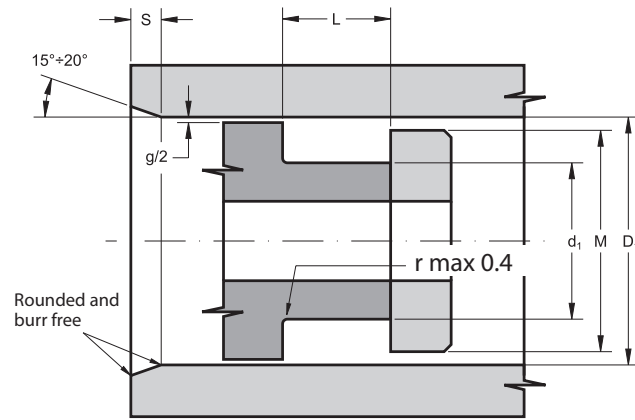

Part.	d <sup>1 f8</sup> d <sup>1 f7</sup>	D <sup>1 H10</sup> D <sup>H10</sup>	L <sup>+0.25</sup>	M	P
HP05 450 490 52	450	490	53	489	451
HP07 450 490 70	450	490	71.5	489	451
HP05 450 500 75	450	500	76.5	499	451
HP07 450 500 101	450	500	103	499	451
HP05 460 500 55	460	500	56	499	461
HP07 460 500 73	460	500	74.5	499	461
HP05 470 500 45	470	500	46	499	471
HP07 470 500 60	470	500	61.5	499	471
HP05 470 510 49	470	510	50	509	471
HP07 470 510 65	470	510	66.5	509	471
HP05 480 520 61.5	480	520	62.5	519	481
HP07 480 520 80.5	480	520	82	519	481
HP05 490 530 56	490	530	57	529	491
HP07 490 530 74	490	530	75.5	529	491
HP05 500 530 50.5	500	530	51.5	529	501
HP07 500 530 65.5	500	530	67	529	501
HP05 500 540 57	500	540	58	539	501
HP07 500 540 77	500	540	78.5	539	501
HP05 500 550 72.5	500	550	74	549	501
HP07 500 550 98	500	550	100	549	501
HP05 505 545 49	505	545	50	544	506
HP07 505 545 67	505	545	68.5	544	506
HP05 510 560 71	510	560	72.5	559	511
HP07 510 560 95	510	560	97	559	511

Part.	d <sup>1 f8</sup> d <sup>1 f7</sup>	D <sup>1 H10</sup> D <sup>H10</sup>	L <sup>+0.25</sup>	M	P
HP05 520 550 45	520	550	46	549	521
HP07 520 550 60	520	550	61.5	549	521
HP05 520 570 75	520	570	76.5	569	521
HP07 520 570 100	520	570	102	569	521
HP05 530 560 42.5	530	560	43.5	559	531
HP07 530 560 57.5	530	560	59	559	531
HP05 540 575 50.5	540	575	51.5	574	541
HP07 540 575 67.5	540	575	69	574	541
HP05 540 580 55	540	580	56	579	541
HP07 540 580 73	540	580	74.5	579	541
HP05 550 590 51.5	550	590	52.5	589	551
HP07 550 590 68.5	550	590	70	589	551
HP05 550 600 75	550	600	76.5	599	551
HP07 550 600 100	550	600	102	599	551
HP05 560 600 50	560	600	51	599	561
HP07 560 600 68	560	600	69.5	599	561
HP05 560 610 64	560	610	65.5	609	561
HP07 560 610 88	560	610	90	609	561
HP05 580 620 48	580	620	49	619	581
HP07 580 620 66	580	620	67.5	619	581
HP05 580 630 68	580	630	69.5	629	581
HP07 580 630 92	580	630	94	629	581
HP05 590 630 51	590	630	52	629	591
HP07 590 630 69	590	630	70.5	629	591

Part.	d <sup>1 f8</sup> d <sup>1 f7</sup>	D <sup>1 H10</sup> D <sup>H10</sup>	L <sup>+0.25</sup>	M	P
HP05 600 630 40	600	630	41	629	601
HP07 600 630 54	600	630	55.5	629	601
HP05 600 640 60	600	640	61	639	601
HP07 600 640 80	600	640	81.5	639	601
HP05 600 650 75	600	650	76.5	649	601
HP07 600 650 100	600	650	102	649	601
HP05 610 650 53	610	650	54	649	611
HP07 610 650 71	610	650	72.5	649	611
HP05 630 680 76	630	680	77.5	679	631
HP07 630 680 102	630	680	104	679	631
HP05 640 670 47	640	670	48	669	641
HP07 640 670 63	640	670	64.5	669	641
HP05 650 690 60	650	690	61	689	651
HP07 650 690 80	650	690	81.5	689	651
HP05 660 700 54	660	700	55	699	661
HP07 660 700 72	660	700	73.5	699	661
HP05 670 710 57.5	670	710	58.5	709	671
HP07 670 710 76.5	670	710	78	709	671
HP05 700 740 60	700	740	61	739	701
HP07 700 740 80	700	740	81.5	739	701
HP05 720 760 61	720	760	62	759	721
HP07 720 760 81	720	760	82.5	759	721
HP05 750 790 48.5	750	790	49.5	789	751
HP07 750 790 65.5	750	790	67	789	751

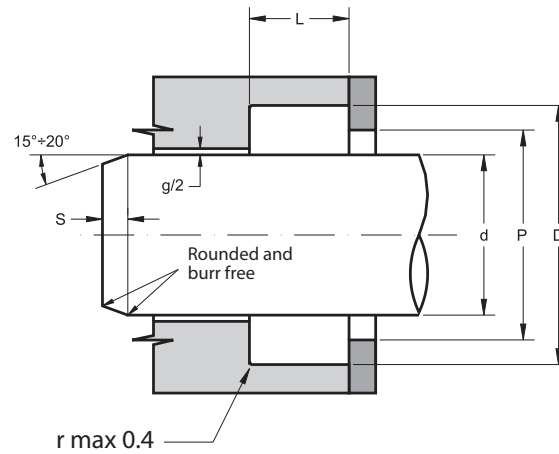
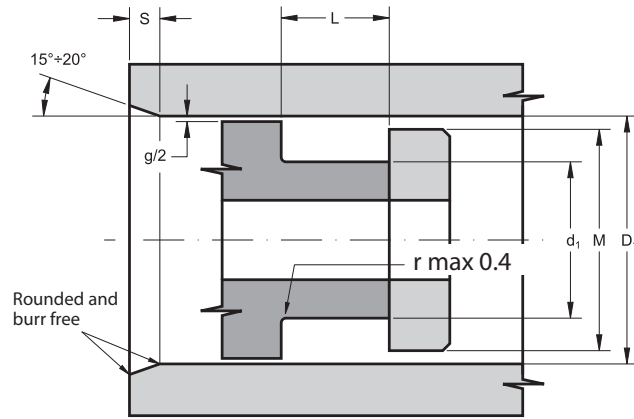

HP03



HP15



HP16



HP07



HP17



HP27



HP

Part.	d <sup>1 f8</sup> d <sup>f7</sup>	D <sup>1 H10</sup> D <sup>H10</sup>	L <sup>+0.25</sup>	M	P
<b>HP05 750 800 75</b>	750	800	76.5	799	751
<b>HP07 750 800 100</b>	750	800	102	799	751
<b>HP05 790 820 44</b>	790	820	45	819	791
<b>HP07 790 820 60</b>	790	820	61.5	819	791
<b>HP05 800 840 56</b>	800	840	57	839	801
<b>HP07 800 840 74</b>	800	840	75.5	839	801
<b>HP05 810 850 59</b>	810	850	60	849	811
<b>HP07 810 850 79</b>	810	850	80.5	849	811
<b>HP05 820 870 75</b>	820	870	76.5	869	821
<b>HP07 820 870 100</b>	820	870	102	869	821
<b>HP05 915 965 66.5</b>	915	965	68	964	916
<b>HP07 915 965 89.5</b>	915	965	91.5	964	916
<b>HP05 1025 1065 56</b>	1025	1065	57	1064	1026
<b>HP07 1025 1065 76</b>	1025	1065	77.5	1064	1026
<b>HP05 1100 1150 80</b>	1100	1150	81.5	1149	1101
<b>HP07 1100 1150 105</b>	1100	1150	107	1149	1101



# FI



The Aston Seals FI type guide rings have been developed to substitute traditional bronze guides in hydraulic cylinders. They guide the rod and prevent metallic contact with the cylinder head when radial forces act perpendicular to the direction of movement.

Chamfered edges prevent splintering of the material during assembly and make the installation into the groove easier.

The compound used for these guides is a medium viscosity glass fibre reinforced acetal resin characterized by high strength, rigidity, hardness, impact resistance, resilience and excellent stability to high and low temperature.

- Extended service life
- Excellent wear-resistance
- Simple design of groove and assembly
- Reduce vibrations
- Low friction
- Good resistance to loads
- Good mechanical stability at high temperature
- Easy installation without expensive auxiliaries

### MATERIAL

	Type	Acetal resin with glass fibre
	Designation	BEARITE

### FIELD OF APPLICATION



Fluids Hydraulic oils (mineral oil based)  
For other fluids contact our technical department

### SURFACE ROUGHNESS

Dynamic surface	$R_a \leq 0.3 \mu\text{m}$	$R_t \leq 2.5 \mu\text{m}$
Static surface	$R_a \leq 2 \mu\text{m}$	$R_t \leq 10 \mu\text{m}$

### CHOICE OF GUIDE RING WIDTH

A rough estimate of guide width can be calculated with the following formula:

$$h_{mm} \geq \frac{F_N \times k}{p_{N/mm^2} \times d_{mm}}$$

where

- $h_{mm}$  • Guide ring width in mm
- $F_N$  • Radial load in N
- $k$  • Safety factor (generally 2)
- $d_{mm}$  • Rod diameter in mm
- $p_{N/mm^2}$  • Surface pressure N/mm<sup>2</sup>  
40 a 20 °C  
30 a 70 °C

Before assembly good cleanliness and lubrication are recommended.

The above data are maximum values, they may be maintained for short periods and can not be used at the same time simultaneously.



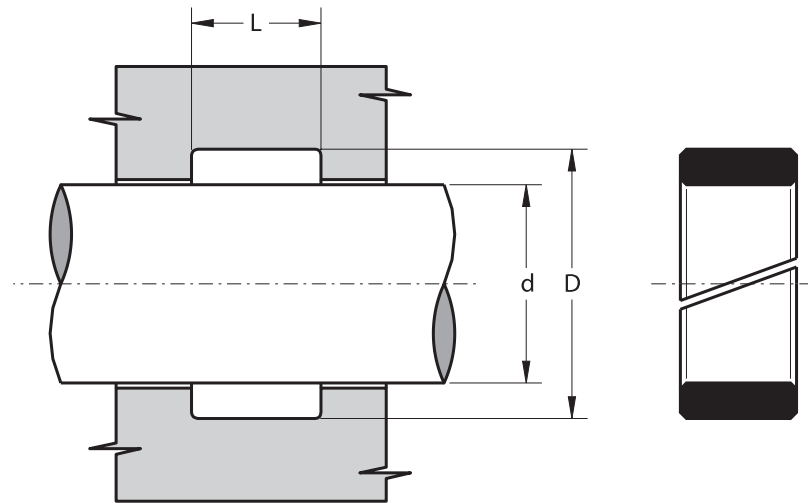

Part.	d <sup>f7</sup>	D <sup>+0.05</sup>	L <sup>+0.25</sup>
FI 12	12	16	9.6
FI 14	14	18	9.6
FI 15	15	19	9.6
FI 16	16	20	9.6
FI 16 20 5.6	16	20	5.6
FI 16 20 8	16	20	8.0
FI 18	18	22	9.6
FI 19 22 3.2	19	22	3.2
FI 20	20	24	9.6
FI 20 26 9.6	20	26	9.6
FI 22	22	26	9.6
FI 25	25	29	9.6
FI 25 31 9.6	25	31	9.6
FI 25.4 28.58 9.78	25.4	28.58	9.78
FI 26	26	30	9.6
FI 28	28	32	9.6
FI 28 31 5.6	28	31	5.6
FI 28 32 8.2	28	32	8.2
FI 30	30	34	9.6
FI 30 33 5.6	30	33	5.6
FI 30 36 9.6	30	36	9.6
FI 31.75 34.93 12.95	31.75	34.93	12.95
FI 31.75 38.1 12.95	31.75	38.1	12.95
FI 32	32	36	9.6

Part.	d <sup>f7</sup>	D <sup>+0.05</sup>	L <sup>+0.25</sup>
FI 32 35.1 4	32	35.1	4.0
FI 32 38 10	32	38	10.0
FI 34	34	38	9.6
FI 34.93 38.1 9.52	34.93	38.1	9.52
FI 35	35	39	9.6
FI 35 39 12.8	35	39	12.8
FI 35 41 9.6	35	41	9.6
FI 36	36	40	9.6
FI 36 40 12.2	36	40	12.2
FI 36 42 9.6	36	42	9.6
FI 38	38	42	9.6
FI 38.1 41.28 20.89	38.1	41.28	20.89
FI 40	40	44	9.6
FI 40 44 6.3	40	44	6.3
FI 40 46 9.6	40	46	9.6
FI 40 46 12.8	40	46	12.8
FI 41.27 47.62 12.7	41.27	47.62	12.7
FI 42	42	46	9.6
FI 44.45 47.5 20.89	44.45	47.5	20.89
FI 44.45 50.8 12.95	44.45	50.8	12.95
FI 45	45	51	9.6
FI 45 51 12.8	45	51	12.8
FI 46	46	52	9.6
FI 47.62 53.97 19.05	47.62	53.97	19.05

Part.	d <sup>f7</sup>	D <sup>+0.05</sup>	L <sup>+0.25</sup>
FI 47.63 50.8 9.52	47.63	50.8	9.52
FI 48	48	54	9.6
FI 50	50	56	9.6
FI 50.8 57.15 25.65	50.8	57.15	25.65
FI 50 56 12.8	50	56	12.8
FI 52	52	58	9.6
FI 52 60 20.5	52	60	20.5
FI 53	53	59	9.6
FI 55	55	61	9.6
FI 55 61 12.8	55	61	12.8
FI 56	56	62	12.8
FI 57.15 63.5 9.52	57.15	63.5	9.52
FI 57.15 63.5 12.95	57.15	63.5	12.95
FI 60	60	66	12.8
FI 60.33 63.5 9.52	60.33	63.5	9.52
FI 63	63	69	12.8
FI 63.5 69.85 12.7	63.5	69.85	12.7
FI 63.5 69.85 19.05	63.5	69.85	19.05
FI 63.5 69.85 25.65	63.5	69.85	25.65
FI 65	65	71	12.8
FI 66	66	72	12.8
FI 69.85 76.2 9.65	69.85	76.2	9.65
FI 69.85 76.2 12.95	69.85	76.2	12.95
FI 70	70	76	12.8

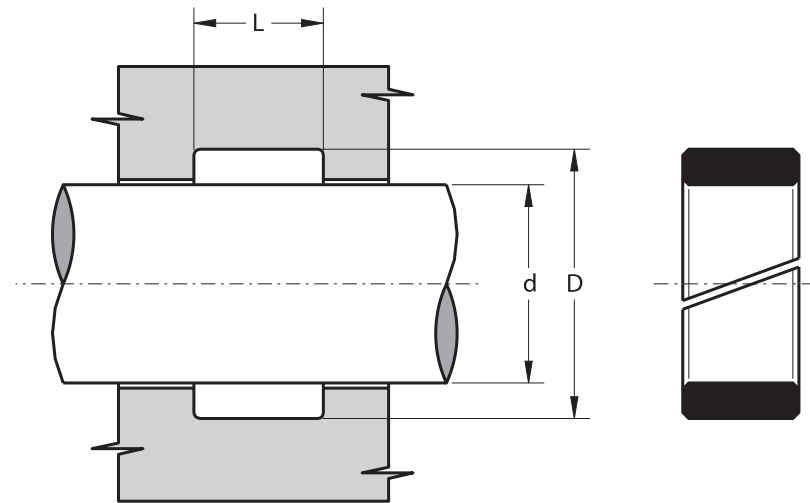

Part.	d <sup>f7</sup>	D <sup>+0.05</sup>	L <sup>+0.25</sup>
FI 72	72	78	12.8
FI 72 80 20.5	72	80	20.5
FI 73	73	79	12.8
FI 75	75	81	12.8
FI 76	76	82	12.8
FI 76.2 82.55 12.8	76.2	82.55	12.8
FI 78	78	84	12.8
FI 79.38 82.55 9.52	79.38	82.55	9.52
FI 80	80	86	12.8
FI 80 86 19.2	80	86	19.2
FI 82.55 88.9 19.3	82.55	88.9	19.3
FI 85	85	91	12.8
FI 86	86	92	12.8
FI 90	90	96	12.8
FI 90 96 19.2	90	96	19.2
FI 92 100 20.5	92	100	20.5
FI 95	95	101	12.8
FI 95.25 101.6 25.65	95.25	101.6	25.65
FI 98.43 101.6 9.52	98.43	101.6	9.52
FI 100	100	106	12.8
FI 105	105	111	12.8
FI 110	110	116	12.8
FI 112 120 20.5	112	120	20.5
FI 115	115	121	12.8

Part.	d <sup>f7</sup>	D <sup>+0.05</sup>	L <sup>+0.25</sup>
FI 120	120	126	12.8
FI 120 126 19.2	120	126	19.2
FI 120 126 25.4	120	126	25.4
FI 120.65 127 25.65	120.65	127	25.65
FI 123	123	129	12.8
FI 123.83 127 9.52	123.83	127	9.52
FI 125	125	131	12.8
FI 130	130	136	12.8
FI 130 136 25.4	130	136	25.4
FI 132 140 10.5	132	140	10.5
FI 132 140 20.5	132	140	20.5
FI 135	135	141	12.8
FI 140	140	146	12.8
FI 143	143	149	12.8
FI 145	145	151	12.8
FI 149.23 152.4 9.52	149.23	152.4	9.52
FI 150	150	156	12.8
FI 150 156 19.2	150	156	19.2
FI 152 160 20.5	152	160	20.5
FI 154	154	160	19.2
FI 155	155	161	19.2
FI 160	160	166	19.2
FI 160 164 10.2	160	164	10.2
FI 165	165	171	19.2

Part.	d <sup>f7</sup>	D <sup>+0.05</sup>	L <sup>+0.25</sup>
FI 170	170	176	19.2
FI 172 180 20.5	172	180	20.5
FI 175	175	181	19.2
FI 180	180	186	19.2
FI 180 184 10.2	180	184	10.2
FI 185	185	191	19.2
FI 190	190	196	19.2
FI 195	195	201	19.2
FI 200	200	206	19.2
FI 205	205	211	19.2
FI 210	210	216	19.2
FI 215	215	221	19.2
FI 216 220 10.2	216	220	10.2
FI 220	220	226	19.2
FI 225	225	231	19.2
FI 230	230	236	19.2
FI 235	235	241	19.2
FI 240	240	246	19.2
FI 245	245	251	19.2
FI 246 250 20.2	246	250	20.2
FI 250	250	256	19.2
FI 255	255	261	19.2
FI 260	260	266	19.2
FI 265	265	271	19.2

FI

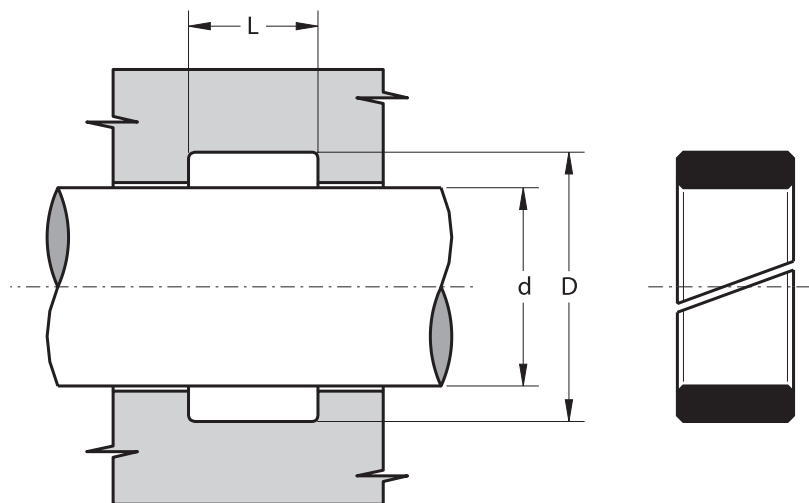

Part.	d <sup>f7</sup>	D <sup>+0.05</sup>	L <sup>+0.25</sup>
FI 270	270	276	19.2
FI 275	275	281	19.2
FI 280	280	286	19.2
FI 285	285	291	19.2
FI 290	290	296	19.2
FI 295	295	301	19.2

# FIL

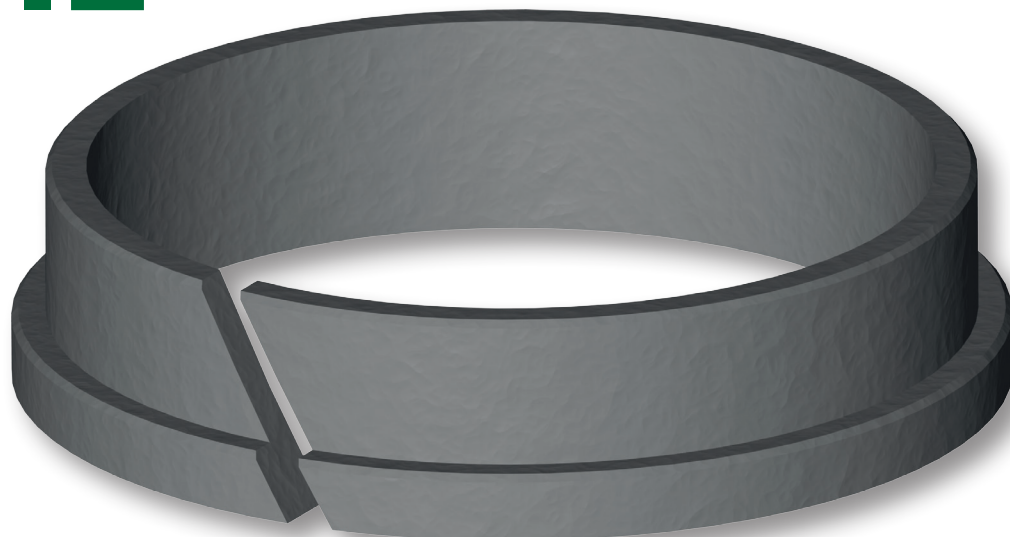

## MATERIAL



Type Acetal resin with glass fibre  
 Designation BEARITE

## FIELD OF APPLICATION

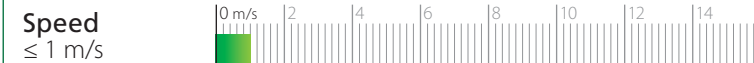

Fluids Hydraulic oils (mineral oil based)  
 For other fluids contact our technical department

## SURFACE ROUGHNESS

Dynamic surface	$R_a \leq 0.3 \mu\text{m}$	$R_t \leq 2.5 \mu\text{m}$
Static surface	$R_a \leq 2 \mu\text{m}$	$R_t \leq 10 \mu\text{m}$

## CHOICE OF GUIDE RING WIDTH

A rough estimate of guide width can be calculated with the following formula:

$$h_{mm} \geq \frac{F_N \times k}{p_{N/mm^2} \times d_{mm}}$$

- where
- $h_{mm}$  • Guide ring width in mm
  - $F_N$  • Radial load in N
  - $k$  • Safety factor (generally 2)
  - $d_{mm}$  • Rod diameter in mm
  - $p_{N/mm^2}$  • Surface pressure  $\text{N/mm}^2$   
 40 a  $20^\circ\text{C}$   
 30 a  $70^\circ\text{C}$

Before assembly good cleanliness and lubrication are recommended.

The above data are maximum values, they may be maintained for short periods and can not be used at the same time simultaneously.

The Aston Seals FIL type guide rings have been developed to substitute traditional bronze guides in hydraulic cylinders. They guide the rod and prevent metallic contact with the cylinder head when radial forces act perpendicular to the direction of movement.

Chamfered edges prevent splintering of the material during assembly and make the installation into the groove easier.

The compound used for these guides is a medium viscosity glass fibre reinforced acetal resin characterized by high strength, rigidity, hardness, impact resistance, resilience and excellent stability to high and low temperature.

- Extended service life
- Excellent wear-resistance
- Simple design of groove and assembly
- Reduce vibrations
- Low friction
- Good resistance to loads
- Good mechanical stability at high temperature
- Easy installation without expensive auxiliaries

**FIL**

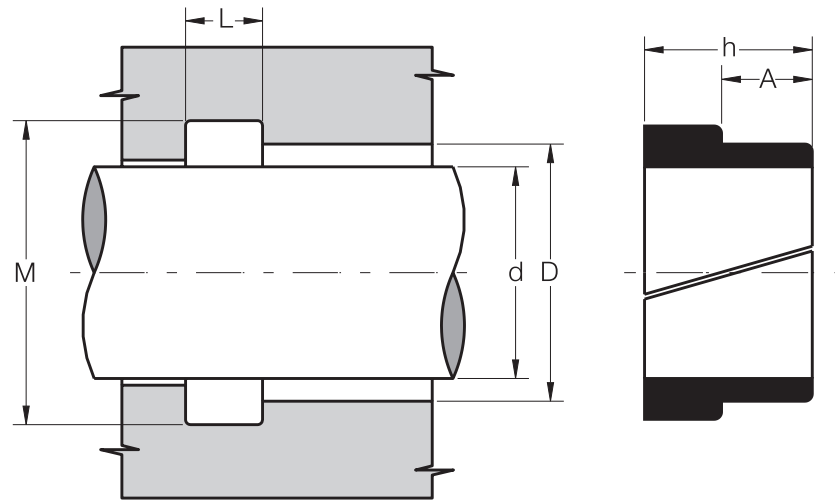

Part.	d <sup>f7</sup>	D <sup>+0.05</sup>	M <sup>+0.2</sup>	L <sup>+0.1</sup>	h	A
FIL 45 51 13	45	51	56	5.0	13	8
FIL 60 66 13	60	66	71	5.0	13	8
FIL 60 66 16	60	66	71	5.0	16	11
FIL 65 70 16	65	70	73	5.0	16	11
FIL 72 77 16	72	77	82.4	5.0	16	11
FIL 75 81 13	75	81	86	5.0	13	8
FIL 78 84 16	78	84	89	5.0	16	11
FIL 85 90 16	85	90	93	5.0	16	11
FIL 91 96 16	91	96	101.4	5.0	16	11
FIL 95 101 13	95	101	106	5.0	13	8
FIL 99 105 16	99	105	110	5.0	16	11
FIL 110 115 16	110	115	120.4	5.0	16	11
FIL 115 121 13	115	121	126	5.0	13	8
FIL 120 126 16	120	126	131	5.0	16	11
FIL 129 136 16	129	136	139.4	5.0	16	11
FIL 132 138 13	132	138	143	5.0	13	8
FIL 141 147 16	141	147	152	5.0	16	11
FIL 162 168 16	162	168	173	5.0	16	11
FIL 183 189 16	183	189	194	5.0	16	11
FIL 207 213 16	207	213	218	5.0	16	11

# FIT

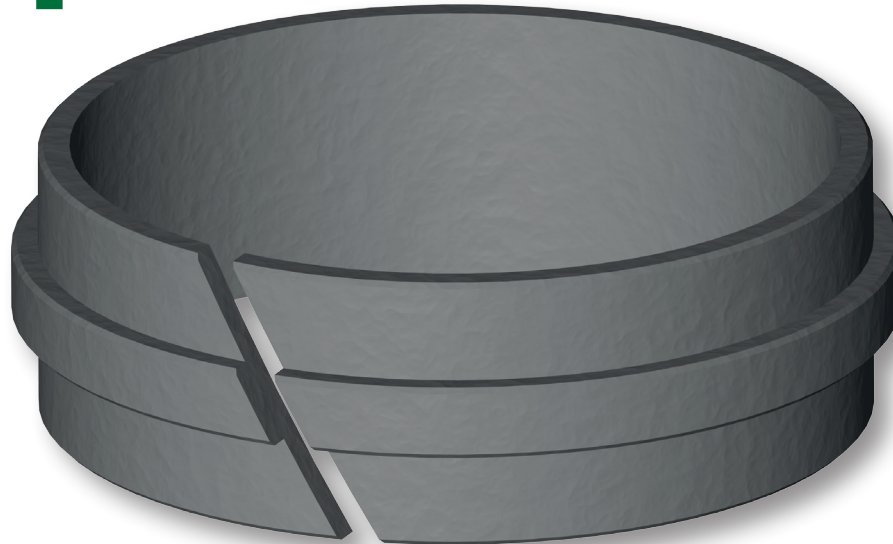

## MATERIAL



Type Acetal resin with glass fibre  
 Designation BEARITE

## FIELD OF APPLICATION

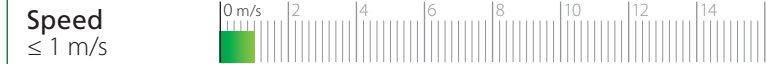

Fluids Hydraulic oils (mineral oil based)  
 For other fluids contact our technical department

## SURFACE ROUGHNESS

Dynamic surface	$R_a \leq 0.3 \mu\text{m}$	$R_t \leq 2.5 \mu\text{m}$
Static surface	$R_a \leq 2 \mu\text{m}$	$R_t \leq 10 \mu\text{m}$

## CHOICE OF GUIDE RING WIDTH

A rough estimate of guide width can be calculated with the following formula:

$$h_{mm} \geq \frac{F_N \times k}{p_{N/mm^2} \times d_{mm}}$$

where

- $h_{mm}$  • Guide ring width in mm
- $F_N$  • Radial load in N
- $k$  • Safety factor (generally 2)
- $d_{mm}$  • Rod diameter in mm
- $p_{N/mm^2}$  • Surface pressure N/mm<sup>2</sup>  
 40 a 20 °C  
 30 a 70 °C

Before assembly good cleanliness and lubrication are recommended.

The above data are maximum values, they may be maintained for short periods and can not be used at the same time simultaneously.

The Aston Seals FIT type guide rings have been developed to substitute traditional bronze guides in hydraulic cylinders. They guide the rod and prevent metallic contact with the cylinder head when radial forces act perpendicular to the direction of movement.

Chamfered edges prevent splintering of the material during assembly and make the installation into the groove easier.

The compound used for these guides is a medium viscosity glass fibre reinforced acetal resin characterized by high strength, rigidity, hardness, impact resistance, resilience and excellent stability to high and low temperature.

- Extended service life
- Excellent wear-resistance
- Simple design of groove and assembly
- Reduce vibrations
- Low friction
- Good resistance to loads
- Good mechanical stability at high temperature
- Easy installation without expensive auxiliaries

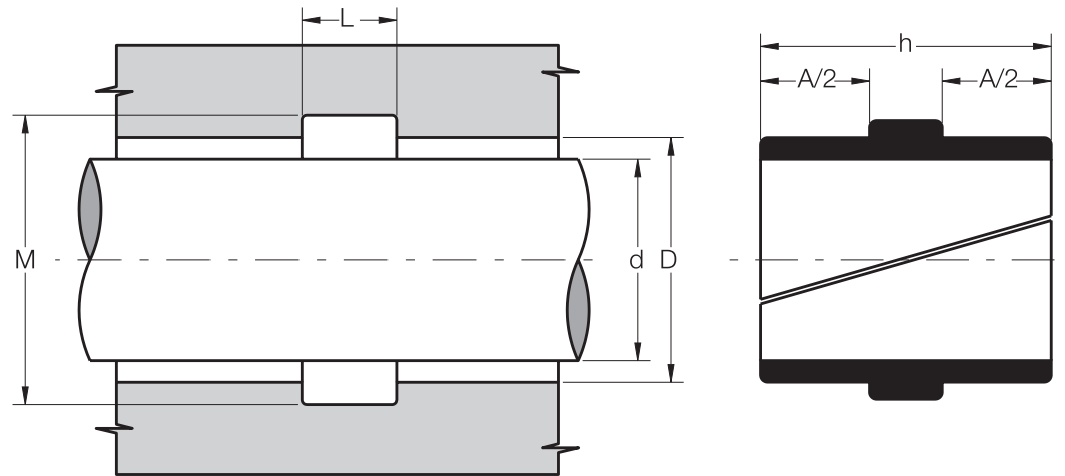

**FIT**

Part.	d <sup>f7</sup>	D <sup>+0.05</sup>	M <sup>+0.2</sup>	L <sup>+0.2</sup>	h	A
<b>FIT 30 34 10</b>	30	34	37	4.0	10	6
<b>FIT 38 42 12.5</b>	38	42	44	4.5	12.5	8
<b>FIT 45 46.8 8.8</b>	45	46.8	49.8	2.5	8.8	6.3
<b>FIT 45 49 10</b>	45	49	53	4.0	10	6
<b>FIT 45 50 20</b>	45	50	54	7.0	20	13
<b>FIT 50 51.8 8.8</b>	50	51.8	54.8	2.5	8.8	6.3
<b>FIT 50 54 20</b>	50	54	58	7.0	20	13
<b>FIT 50 55 20</b>	50	55	59	7.0	20	13
<b>FIT 55 60 16</b>	55	60	64.5	8.0	16	8
<b>FIT 55 61 27</b>	55	61	65	6.0	27	21
<b>FIT 60 61.8 8.8</b>	60	61.8	64.8	3.0	8.8	5.8
<b>FIT 60 65 20</b>	60	65	69	7.0	20	13
<b>FIT 61 65 10</b>	61	65	69	4.0	10	6
<b>FIT 65 66.8 8.8</b>	65	66.8	69.8	3.0	8.8	5.8
<b>FIT 70 74 20</b>	70	74	78	7.0	20	13
<b>FIT 72 79 31</b>	72	79	82	8.0	31	23
<b>FIT 75 76.8 13.2</b>	75	76.8	79.8	3.5	13.2	9.7

Part.	d <sup>f7</sup>	D <sup>+0.05</sup>	M <sup>+0.2</sup>	L <sup>+0.2</sup>	h	A
<b>FIT 75 80 16</b>	75	80	84.5	8.0	16	8
<b>FIT 75.3 80.5 30</b>	75.3	80.5	85	8.1	30	21.9
<b>FIT 76 80 12</b>	76	80	84	5.0	12	7
<b>FIT 80 83 13.2</b>	80	83	86	4.5	13.2	8.7
<b>FIT 85 90 27</b>	85	90	95	8.0	27	19
<b>FIT 85 91 27</b>	85	91	95	6.0	27	21
<b>FIT 88 92 15</b>	88	92	97	6.0	15	9
<b>FIT 88.5 92.5 20</b>	88.5	92.5	96.5	7.0	20	13
<b>FIT 90 96 26</b>	90	96	100	7.0	26	19
<b>FIT 90.3 95.5 30</b>	90.3	95.5	100	8.0	30	22
<b>FIT 91 95 15</b>	91	95	100	6.0	15	9
<b>FIT 95 100 16</b>	95	100	104.5	8.0	16	8
<b>FIT 97 103 30</b>	97	103	107.5	10.0	30	20
<b>FIT 105 111 31</b>	105	111	115	8.0	31	23
<b>FIT 105.3 110.5 30</b>	105.3	110.5	115	8.0	30	22
<b>FIT 107 112 16</b>	107	112	117	6.0	16	10
<b>FIT 108.5 112.5 20</b>	108.5	112.5	116.5	7.0	20	13

Part.	d <sup>f7</sup>	D <sup>+0.05</sup>	M <sup>+0.2</sup>	L <sup>+0.2</sup>	h	A
<b>FIT 110 116 26</b>	110	116	120	7.0	26	19
<b>FIT 115 120 16</b>	115	120	124.5	8.0	16	8
<b>FIT 118 124 30</b>	118	124	128.5	10.0	30	20
<b>FIT 125 130 29</b>	125	130	134	8.0	29	21
<b>FIT 126 131 18</b>	126	131	136	7.0	18	11
<b>FIT 128.5 132.5 20</b>	128.5	132.5	136.5	7.0	20	13
<b>FIT 132 138 26</b>	132	138	142	7.0	26	19
<b>FIT 135 140 16</b>	135	140	144.5	8.0	16	8
<b>FIT 140 146 30</b>	140	146	150.5	10.0	30	20
<b>FIT 148.5 152.5 20</b>	148.5	152.5	156.5	7.0	20	13
<b>FIT 152 158 26</b>	152	158	162	7.0	26	19
<b>FIT 171.5 175.5 20</b>	171.5	175.5	179.5	7.0	20	13
<b>FIT 172 178 26</b>	172	178	182	7.0	26	19
<b>FIT 194 200 26</b>	194	200	204	7.0	26	19
<b>FIT 194.5 198.5 20</b>	194.5	198.5	202.5	7.0	20	13

FE



**MATERIAL**



Type Acetal resin with glass fibre  
Designation BEARITE

**FIELD OF APPLICATION**

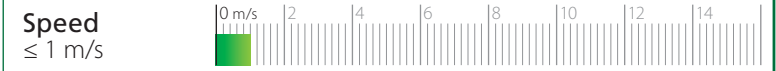

Fluids Hydraulic oils (mineral oil based)  
For other fluids contact our technical department

**SURFACE ROUGHNESS**

Dynamic surface	Ra ≤ 0.3 µm	Rt ≤ 2.5 µm
Static surface	Ra ≤ 2 µm	Rt ≤ 10 µm

**CHOICE OF GUIDE RING WIDTH**

A rough estimate of guide width can be calculated with the following formula:

$$h_{mm} \geq \frac{F_N \times k}{p_{N/mm^2} \times d_{mm}}$$

- where
- $h_{mm}$  • Guide ring width in mm
  - $F_N$  • Radial load in N
  - $k$  • Safety factor (generally 2)
  - $d_{mm}$  • Rod diameter in mm
  - $p_{N/mm^2}$  • Surface pressure N/mm<sup>2</sup>  
40 a 20 °C  
30 a 70 °C

Before assembly good cleanliness and lubrication are recommended.

The above data are maximum values, they may be maintained for short periods and can not be used at the same time simultaneously.

The Aston Seals FE type guide rings have been developed to substitute traditional bronze guides in hydraulic cylinders. They guide the piston and prevent metallic contact with the cylinder when radial forces act perpendicular to the direction of movement.

Chamfered edges prevent the splintering of the material during assembly and make the installation into the groove easier.

The compound used for these guides is a medium viscosity glass fibre reinforced acetal resin characterized by high strength, rigidity, hardness, impact resistance, resilience and excellent stability to high and low temperature.

- Extended service life
- Excellent wear-resistance
- Simple design of groove and assembly
- Reduce vibrations
- Low friction
- Good resistance to loads
- Good mechanical stability at high temperature
- Easy installation without expensive auxiliaries



FE

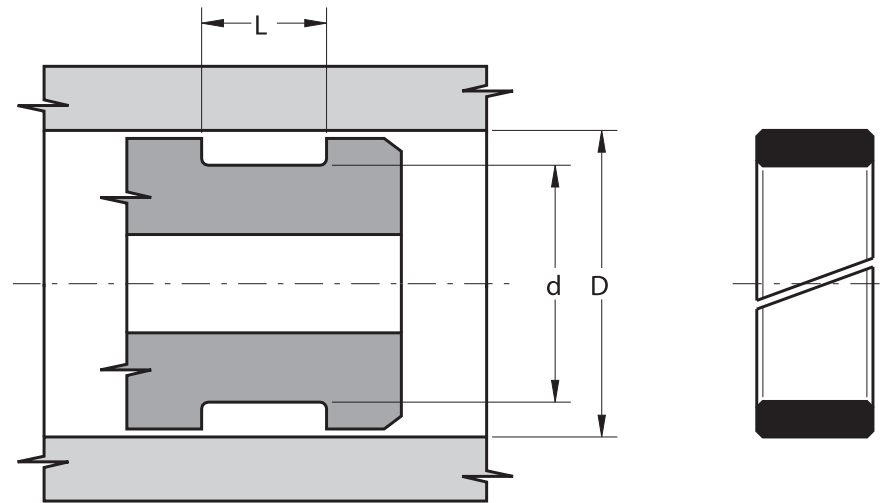

Part.	D <sup>H8</sup>	d <sup>-0.05</sup>	L <sup>+0.25</sup>
FE 16	16	12	9.6
FE 18	18	14	9.6
FE 20	20	16	9.6
FE 20 16 5.6	20	16	5.6
FE 22	22	18	9.6
FE 22 19 3.2	22	19	3.2
FE 24	24	20	9.6
FE 25 19 9.6	25	19	9.6
FE 25 21 8.2	25	21	8.2
FE 25	25	21	9.6
FE 26	26	22	9.6
FE 28	28	24	9.6
FE 28.58 25.4 9.78	28.58	25.4	9.78
FE 30	30	26	9.6
FE 32	32	28	9.6
FE 32 28 8.2	32	28	8.2
FE 34	34	30	9.6
FE 34.93 31.75 12.95	34.93	31.75	12.95
FE 35	35	31	9.6
FE 36	36	32	9.6
FE 38.1 31.75 12.95	38.1	31.75	12.95
FE 38.1 34.93 9.52	38.1	34.93	9.52
FE 40	40	36	9.6
FE 40 34 9.6	40	34	9.6

Part.	D <sup>H8</sup>	d <sup>-0.05</sup>	L <sup>+0.25</sup>
FE 40 36 12.2	40	36	12.2
FE 41.28 38.1 20.89	41.28	38.1	20.89
FE 42	42	38	9.6
FE 44 40 6.3	44	40	6.3
FE 45	45	41	9.6
FE 46	46	42	9.6
FE 47.5 44.45 20.89	47.5	44.45	20.89
FE 47.62 41.27 12.7	47.62	41.27	12.7
FE 48	48	42	9.6
FE 49	49	43	9.6
FE 50	50	44	9.6
FE 50.8 44.45 12.7	50.8	44.45	12.7
FE 50.8 44.45 12.95	50.8	44.45	12.95
FE 50.8 47.63 9.52	50.8	47.63	9.52
FE 53.97 47.62 19.05	53.97	47.62	19.05
FE 55	55	49	12.8
FE 55 49 9.6	55	49	9.6
FE 56	56	50	12.8
FE 57.15 50.8 25.65	57.15	50.8	25.65
FE 57.16 50.25 6.1	57.16	50.25	6.1
FE 60	60	54	12.8
FE 60 52 20.5	60	52	20.5
FE 60 54 9.6	60	54	9.6
FE 63	63	57	12.8

Part.	D <sup>H8</sup>	d <sup>-0.05</sup>	L <sup>+0.25</sup>
FE 63 57 10	63	57	10.0
FE 63.5 57.15 9.52	63.5	57.15	9.52
FE 63.5 57.15 12.7	63.5	57.15	12.7
FE 63.5 57.15 12.95	63.5	57.15	12.95
FE 63.5 60.33 9.52	63.5	60.33	9.52
FE 65	65	59	12.8
FE 69.85 63.5 12.7	69.85	63.5	12.7
FE 69.85 63.5 19.05	69.85	63.5	19.05
FE 69.85 63.5 25.65	69.85	63.5	25.65
FE 70	70	64	12.8
FE 74	74	68	12.8
FE 75	75	69	12.8
FE 75 69 9.6	75	69	9.6
FE 75 71 15.1	75	71	15.1
FE 76.2 69.85 9.65	76.2	69.85	9.65
FE 76.2 69.85 12.95	76.2	69.85	12.95
FE 80	80	74	12.8
FE 80 72 20.5	80	72	20.5
FE 82.55 79.38 9.52	82.55	79.38	9.52
FE 85	85	79	12.8
FE 88.9 82.55 19.3	88.9	82.55	19.3
FE 90 84 10	90	84	10.0
FE 90	90	84	12.8
FE 94	94	88	12.8

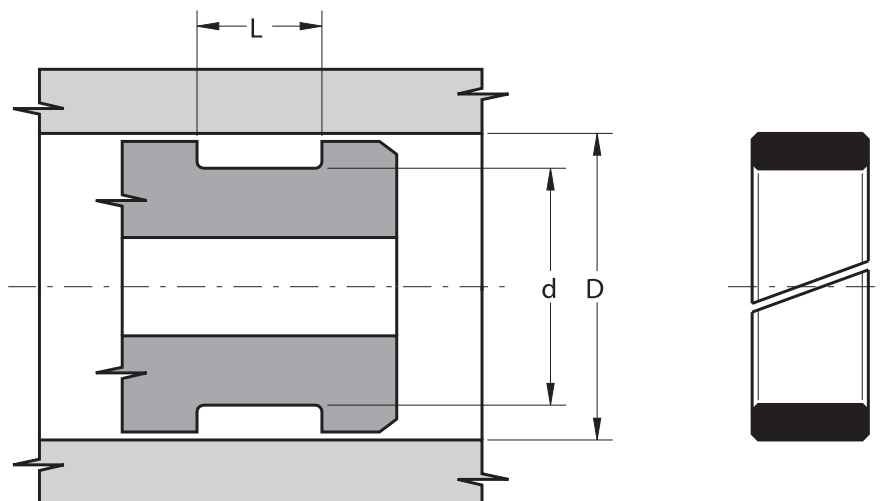

Part.	D <sup>H8</sup>	d <sup>-0.05</sup>	L <sup>+0.25</sup>
FE 95	95	89	12.8
FE 96	96	90	12.8
FE 100	100	94	12.8
FE 100 92 20.5	100	92	20.5
FE 101.6 95.25 25.65	101.6	95.25	25.65
FE 101.6 98.43 9.52	101.6	98.43	9.52
FE 105	105	99	12.8
FE 110	110	104	12.8
FE 115	115	109	12.8
FE 120	120	114	12.8
FE 120 112 20.5	120	112	20.5
FE 125	125	119	12.8
FE 126	126	120	12.8
FE 127 120.65 25.65	127	120.65	25.65
FE 127 123.83 9.52	127	123.83	9.52
FE 130	130	124	12.8
FE 135	135	129	12.8
FE 135 129 19.2	135	129	19.2
FE 140	140	134	12.8
FE 140 132 10.5	140	132	10.5
FE 140 132 20.5	140	132	20.5
FE 145	145	139	12.8

Part.	D <sup>H8</sup>	d <sup>-0.05</sup>	L <sup>+0.25</sup>
FE 147	147	141	12.8
FE 150	150	144	12.8
FE 152.4 146.05 12.7	152.4	146.05	12.7
FE 152.4 149.23 9.52	152.4	149.23	9.52
FE 155	155	149	19.2
FE 160	160	154	19.2
FE 160 152 20.5	160	152	20.5
FE 164 160 10.2	164	160	10.2
FE 165	165	159	19.2
FE 170	170	164	19.2
FE 175	175	169	19.2
FE 177.8 171.45 12.7	177.8	171.45	12.7
FE 180	180	174	19.2
FE 180 172 20.5	180	172	20.5
FE 184 180 10.2	184	180	10.2
FE 185	185	179	19.2
FE 190	190	184	19.2
FE 195	195	189	19.2
FE 198	198	192	19.2
FE 200	200	194	19.2
FE 205	205	199	19.2
FE 210	210	204	19.2

Part.	D <sup>H8</sup>	d <sup>-0.05</sup>	L <sup>+0.25</sup>
FE 215	215	209	19.2
FE 220	220	214	19.2
FE 220 216 10.2	220	216	10.2
FE 225	225	219	19.2
FE 230	230	224	19.2
FE 235	235	229	19.2
FE 240	240	234	19.2
FE 245	245	239	19.2
FE 250	250	244	19.2
FE 250 246 20.2	250	246	20.2
FE 255	255	249	19.2
FE 260	260	254	19.2
FE 265	265	259	19.2
FE 270	270	264	19.2
FE 275	275	269	19.2
FE 280	280	274	19.2
FE 285	285	279	19.2
FE 290	290	284	19.2
FE 295	295	289	19.2
FE 300	300	294	19.2



# FR



## MATERIAL

	<b>Type</b>	Acetal resin with glass fibre
	<b>Designation</b>	BEARITE

## FIELD OF APPLICATION

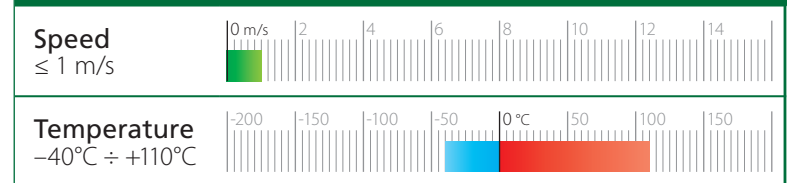

<b>Fluids</b>	Hydraulic oils (mineral oil based) For other fluids contact our technical department
---------------	---

## SURFACE ROUGHNESS

<b>Dynamic surface</b>	Ra ≤ 0.3 µm	Rt ≤ 2.5 µm
<b>Static surface</b>	Ra ≤ 2 µm	Rt ≤ 10 µm

## CHOICE OF GUIDE RING WIDTH

A rough estimate of guide width can be calculated with the following formula:

$$h_{mm} \geq \frac{F_N \times k}{p_{N/mm^2} \times d_{mm}}$$

- where
- $h_{mm}$  • Guide ring width in mm
  - $F_N$  • Radial load in N
  - $k$  • Safety factor (generally 2)
  - $d_{mm}$  • Rod diameter in mm
  - $p_{N/mm^2}$  • Surface pressure N/mm<sup>2</sup>  
40 a 20 °C  
30 a 70 °C

Before assembly good cleanliness and lubrication are recommended.

The above data are maximum values, they may be maintained for short periods and can not be used at the same time simultaneously.

The Aston Seals FR type guide rings have been developed to substitute traditional bronze guides in hydraulic cylinders. They guide the rod or the piston and prevent metallic contact with the cylinder when radial forces act perpendicular to the direction of movement.

Chamfered edges prevent splintering of the material during assembly and make the installation into the groove easier.

The compound used for these guides is a medium viscosity glass fibre reinforced acetal resin characterized by high strength, rigidity, hardness, impact resistance, resilience and excellent stability to high and low temperature.

- Extended service life
- Dimension suitable for both rod and piston
- Excellent wear-resistance
- Simple design of groove and assembly
- Reduce vibrations
- Low friction
- Good resistance to loads
- Good mechanical stability at high temperature
- Easy installation without expensive auxiliaries

# FR

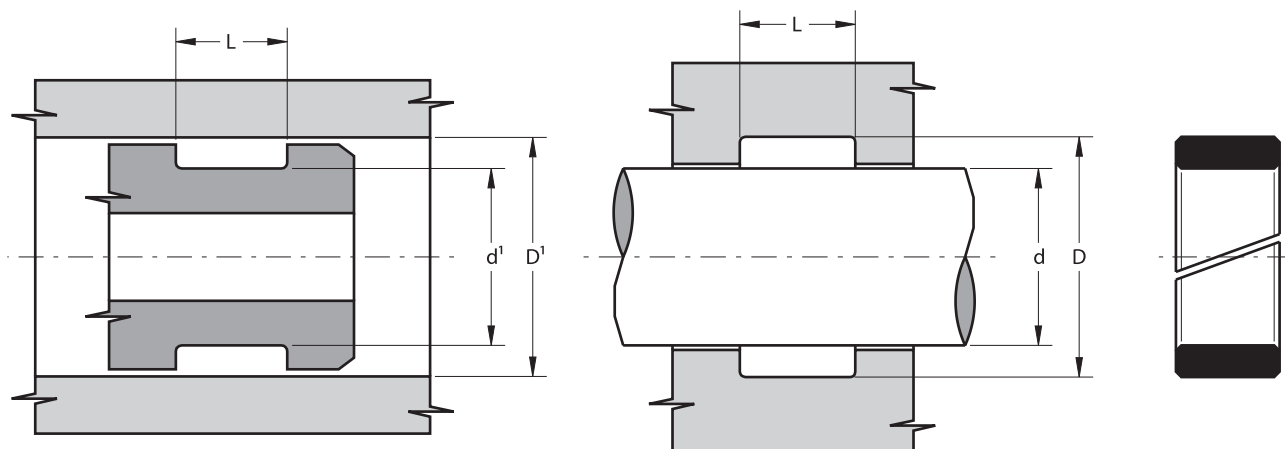

Part.	$d^{1-0.05}$ $d_{f7}$	$D^{1H8}$ $D_{+0.05}$	$L_{+0.25}$
FR 16 19 5.5	16	19	5.5
FR 16 19 6.3	16	19	6.3
FR 16 19.1 4	16	19.1	4.0
FR 18 21.1 3.9	18	21.1	3.9
FR 20 25 5.6	20	25	5.6
FR 21.9 25 4	21.9	25	4.0
FR 25 30 5.6	25	30	5.6
FR 25 30 9.7	25	30	9.7
FR 27 32 4.2	27	32	4.2
FR 27 32 5.6	27	32	5.6
FR 27.3 32 9.82	27.3	32	9.82
FR 30 35 5.6	30	35	5.6
FR 30 35 9.7	30	35	9.7
FR 30 35 19.4	30	35	19.4
FR 32 37 5.6	32	37	5.6
FR 32 37 9.7	32	37	9.7
FR 32 37 15	32	37	15.0
FR 33 38 5.6	33	38	5.6
FR 35 40 4.5	35	40	4.5
FR 35 40 5.6	35	40	5.6
FR 35 40 6.3	35	40	6.3
FR 35 40 9.7	35	40	9.7
FR 36 41 5.6	36	41	5.6
FR 38 43 9.7	38	43	9.7

Part.	$d^{1-0.05}$ $d_{f7}$	$D^{1H8}$ $D_{+0.05}$	$L_{+0.25}$
FR 40 45 5.6	40	45	5.6
FR 40 45 9.7	40	45	9.7
FR 43.7 50 7.2	43.7	50	7.2
FR 45 50 5.6	45	50	5.6
FR 45 50 6.3	45	50	6.3
FR 45 50 8.1	45	50	8.1
FR 45 50 9.7	45	50	9.7
FR 45 50 15	45	50	15.0
FR 45 50 19.4	45	50	19.4
FR 45.4 50 6.7	45.4	50	6.7
FR 46 50 9.7	46	50	9.7
FR 46 50 10.2	46	50	10.2
FR 50 55 5.6	50	55	5.6
FR 50 55 9.7	50	55	9.7
FR 50 55 15	50	55	15.0
FR 50 55 20	50	55	20.0
FR 55 60 5.6	55	60	5.6
FR 55 60 9.7	55	60	9.7
FR 55 60 15	55	60	15.0
FR 56 60 10.2	56	60	10.2
FR 57.18 62.18 19.8	57.18	62.18	19.8
FR 58 63 5.6	58	63	5.6
FR 58 63 9.7	58	63	9.7
FR 58 63 15	58	63	15.0

Part.	$d^{1-0.05}$ $d_{f7}$	$D^{1H8}$ $D_{+0.05}$	$L_{+0.25}$
FR 59 63 10	59	63	10.0
FR 60 65 5.6	60	65	5.6
FR 60 65 9.7	60	65	9.7
FR 60 65 15	60	65	15.0
FR 60 65 19.4	60	65	19.4
FR 60 65 20	60	65	20.0
FR 65 70 5.6	65	70	5.6
FR 65 70 9.7	65	70	9.7
FR 66 70 10.2	66	70	10.2
FR 67 72 5.6	67	72	5.6
FR 70 75 5.6	70	75	5.6
FR 70 75 9.7	70	75	9.7
FR 71.2 76.2 20	71.2	76.2	20.0
FR 75 80 5.6	75	80	5.6
FR 75 80 9.7	75	80	9.7
FR 75 80 19.4	75	80	19.4
FR 76 80 10	76	80	10.0
FR 80 85 5.6	80	85	5.6
FR 80 85 9.7	80	85	9.7
FR 80 85 15	80	85	15.0
FR 85 90 5.6	85	90	5.6
FR 85 90 9.7	85	90	9.7
FR 88.9 93.9 19.8	88.9	93.9	19.8
FR 90 95 5.6	90	95	5.6

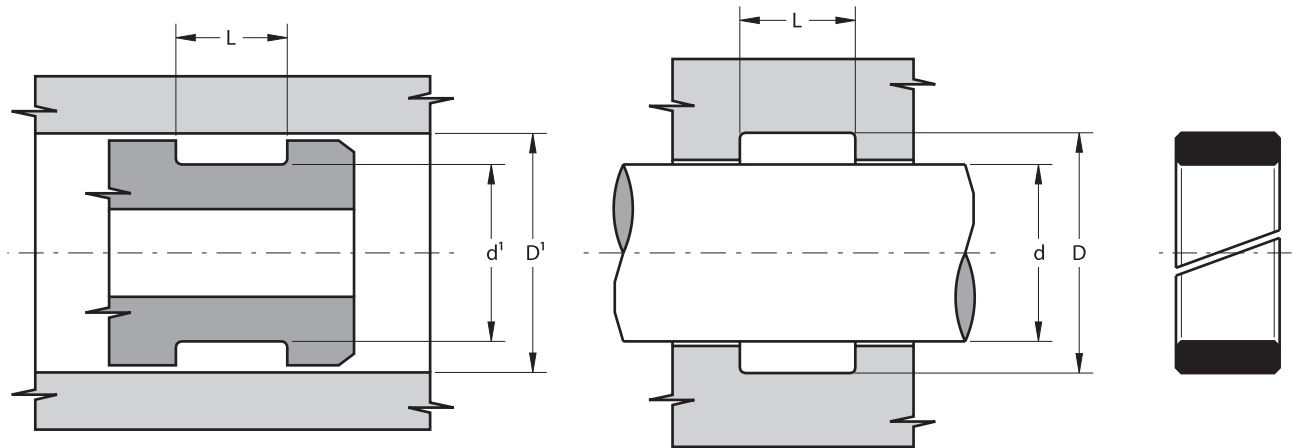

Part.	$d^{1-0.05}$ d f7	$D^{1\text{ HB}}$ D +0.05	$L^{+0.25}$
FR 90 95 9.7	90	95	9.7
FR 90 95 19.4	90	95	19.4
FR 92 97 9.7	92	97	9.7
FR 95 100 5.6	95	100	5.6
FR 95 100 9.7	95	100	9.7
FR 96 100 10	96	100	10.0
FR 100 105 5.6	100	105	5.6
FR 100 105 9.7	100	105	9.7
FR 103 108 20	103	108	20.0
FR 105 110 9.7	105	110	9.7
FR 105 110 15	105	110	15.0
FR 105 110 19.4	105	110	19.4
FR 110 115 9.7	110	115	9.7
FR 115 120 9.7	115	120	9.7
FR 115 120 15	115	120	15.0
FR 120 125 5.6	120	125	5.6
FR 120 125 9.7	120	125	9.7
FR 122 127 9.7	122	127	9.7
FR 122 127 19.4	122	127	19.4
FR 130 135 9.7	130	135	9.7
FR 135 140 15	135	140	15.0
FR 145 150 19.4	145	150	19.4

Part.	$d^{1-0.05}$ d f7	$D^{1\text{ HB}}$ D +0.05	$L^{+0.25}$
FR 145 150 20	145	150	20.0
FR 155 160 15	155	160	15.0
FR 175 180 9.7	175	180	9.7
FR 175 180 15	175	180	15.0
FR 175 180 25	175	180	25.0
FR 176 180 25	176	180	25.0
FR 195 200 15	195	200	15.0
FR 200 205 15	200	205	15.0
FR 215 220 20	215	220	20.0
FR 225 230 15	225	230	15.0
FR 225 230 25	225	230	25.0
FR 230 235 15	230	235	15.0
FR 230 235 25	230	235	25.0
FR 235 240 15	235	240	15.0
FR 235 240 25	235	240	25.0
FR 240 245 15	240	245	15.0
FR 240 245 25	240	245	25.0
FR 245 250 15	245	250	15.0
FR 245 250 25	245	250	25.0
FR 250 255 15	250	255	15.0
FR 260 265 15	260	265	15.0



# GRF

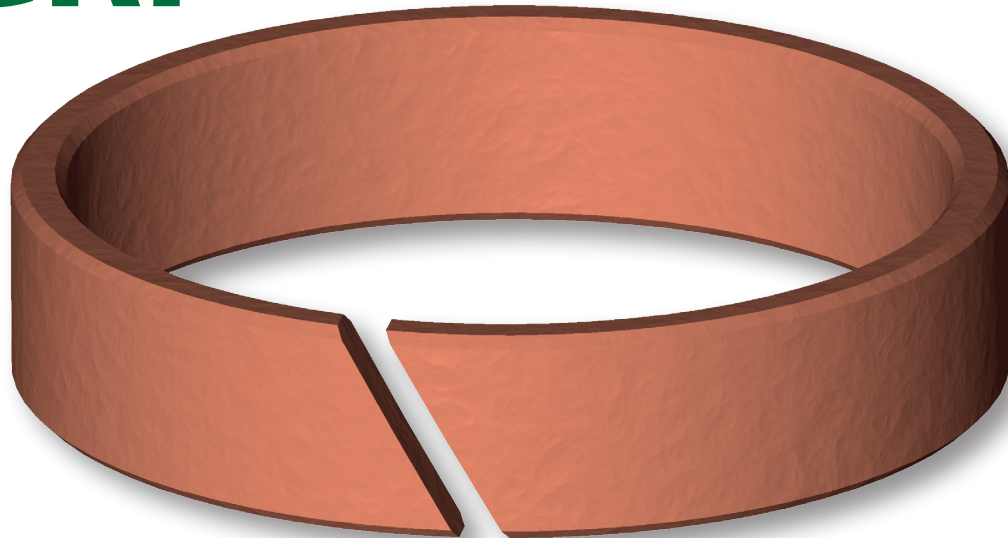

## MATERIAL



**Type**  
Phenolic resin in cotton fabric

**Designation**  
PHENOLITE

## FIELD OF APPLICATION



**Fluids**  
Hydraulic oils (mineral oil based)  
For other fluids contact our technical department

## SURFACE ROUGHNESS

<b>Dynamic surface</b>	Ra ≤ 0.3 μm	Rt ≤ 2.5 μm
<b>Static surface</b>	Ra ≤ 2 μm	Rt ≤ 10 μm

## CHOICE OF GUIDE RING WIDTH

A rough estimate of guide width can be calculated with the following formula:

$$h_{mm} \geq \frac{F_N \times k}{p_{N/mm^2} \times d_{mm}}$$

- where
- $h_{mm}$  • Guide ring width in mm
  - $F_N$  • Radial load in N
  - $k$  • Safety factor (generally 2)
  - $d_{mm}$  • Rod diameter in mm
  - $p_{N/mm^2}$  • Surface pressure N/mm<sup>2</sup>  
100 a 20 °C  
75 a 70 °C  
50 a 120 °C

Before assembly good cleanliness and lubrication are recommended.

The above data are maximum values, they may be maintained for short periods and can not be used at the same time simultaneously.

The Aston Seals GRF type guide rings have been developed to substitute traditional bronze guides in hydraulic cylinders. They guide the rod or the piston and prevent metallic contact with the cylinder when radial forces act perpendicular to the direction of movement.

Since GRF guide rings are machined from tube, the thickness can be very precise for high guiding performance.

The compound used for these guides is a cotton fabric bound with thermosetting phenolic resin characterized by excellent heavy loads resistance, rigidity, hardness and high service temperature.

- Excellent resistance to heavy loads
- High precision of guiding
- Good resistance to “diesel effect”
- Extended service life
- Dimension suitable for both rod and piston
- Simple design of groove and assembly
- Low friction
- Good mechanical stability at high temperature
- Easy installation without expensive auxiliaries



# GRF

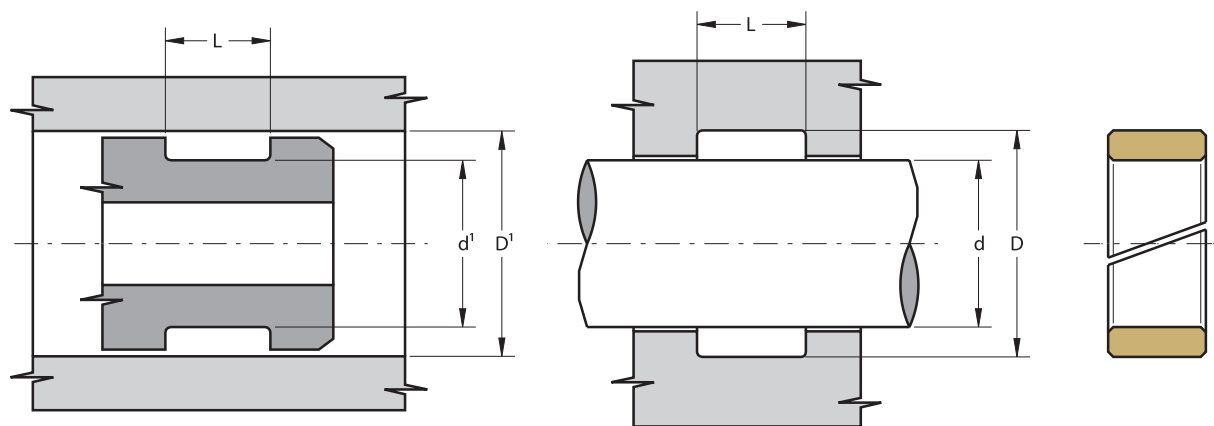

Part.	$d^{1\ h8}$ $d_{f8}$	$D^{1\ H9}$ $D_{H8}$	$L_{+0.2}$
GRF 20 25 9.7	20	25	9.7
GRF 25 30 9.7	25	30	9.7
GRF 27 32 9.7	27	32	9.7
GRF 30 35 9.7	30	35	9.7
GRF 35 40 9.7	35	40	9.7
GRF 36 41 9.7	36	41	9.7
GRF 36 41 15	36	41	15.0
GRF 37 42 9.7	37	42	9.7
GRF 40 45 9.7	40	45	9.7
GRF 45 50 9.7	45	50	9.7
GRF 50 55 9.7	50	55	9.7
GRF 50 55 15	50	55	15.0
GRF 55 60 9.7	55	60	9.7
GRF 55 60 15	55	60	15.0
GRF 56 61 9.7	56	61	9.7
GRF 58 63 9.7	58	63	9.7
GRF 58 63 15	58	63	15.0
GRF 60 65 9.7	60	65	9.7
GRF 60 65 15	60	65	15.0
GRF 63 68 9.7	63	68	9.7
GRF 65 70 9.7	65	70	9.7
GRF 65 70 15	65	70	15.0
GRF 70 75 9.7	70	75	9.7
GRF 70 75 15	70	75	15.0

Part.	$d^{1\ h8}$ $d_{f8}$	$D^{1\ H9}$ $D_{H8}$	$L_{+0.2}$
GRF 75 80 9.7	75	80	9.7
GRF 75 80 15	75	80	15.0
GRF 80 85 9.7	80	85	9.7
GRF 80 85 15	80	85	15.0
GRF 85 90 9.7	85	90	9.7
GRF 85 90 15	85	90	15.0
GRF 90 95 9.7	90	95	9.7
GRF 90 95 15	90	95	15.0
GRF 94 99 9.7	94	99	9.7
GRF 95 100 9.7	95	100	9.7
GRF 95 100 15	95	100	15.0
GRF 100 105 9.7	100	105	9.7
GRF 100 105 15	100	105	15.0
GRF 105 110 9.7	105	110	9.7
GRF 105 110 15	105	110	15.0
GRF 110 115 9.7	110	115	9.7
GRF 110 115 15	110	115	15.0
GRF 115 120 9.7	115	120	9.7
GRF 115 120 15	115	120	15.0
GRF 120 125 9.7	120	125	9.7
GRF 120 125 15	120	125	15.0
GRF 125 130 9.7	125	130	9.7
GRF 125 130 15	125	130	15.0
GRF 130 135 9.7	130	135	9.7

Part.	$d^{1\ h8}$ $d_{f8}$	$D^{1\ H9}$ $D_{H8}$	$L_{+0.2}$
GRF 130 135 15	130	135	15.0
GRF 135 140 9.7	135	140	9.7
GRF 135 140 15	135	140	15.0
GRF 140 145 9.7	140	145	9.7
GRF 140 145 15	140	145	15.0
GRF 145 150 9.7	145	150	9.7
GRF 145 150 15	145	150	15.0
GRF 150 155 9.7	150	155	9.7
GRF 150 155 15	150	155	15.0
GRF 155 160 9.7	155	160	9.7
GRF 155 160 15	155	160	15.0
GRF 160 165 9.7	160	165	9.7
GRF 160 165 15	160	165	15.0
GRF 165 170 15	165	170	15.0
GRF 170 175 9.7	170	175	9.7
GRF 170 175 15	170	175	15.0
GRF 175 180 9.7	175	180	9.7
GRF 175 180 15	175	180	15.0
GRF 180 185 9.7	180	185	9.7
GRF 180 185 15	180	185	15.0
GRF 185 190 9.7	185	190	9.7
GRF 185 190 15	185	190	15.0
GRF 190 195 15	190	195	15.0
GRF 195 200 9.7	195	200	9.7

GRF

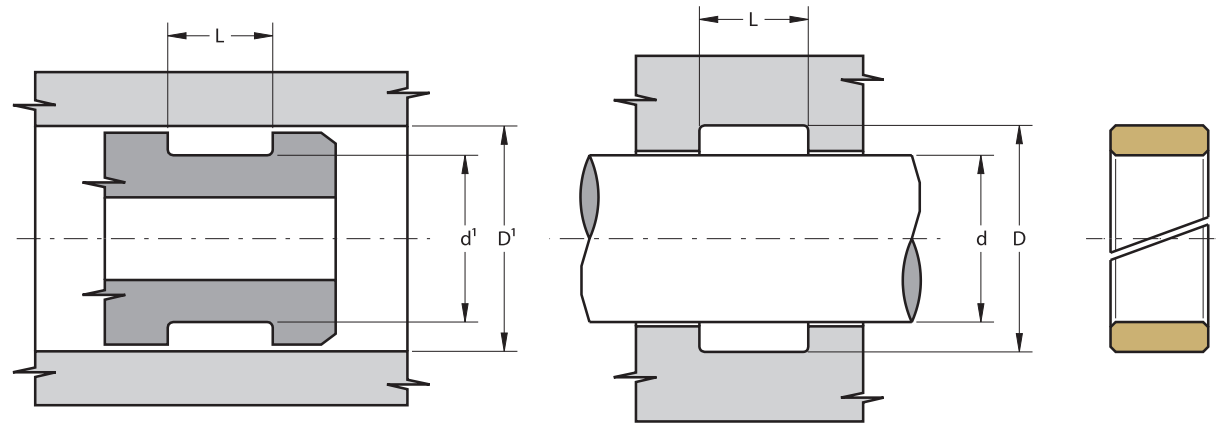

Part.	$d_1^{h8}$ $d_{f8}$	$D_1^{H9}$ $D_{H8}$	$L^{+0.2}$
<b>GRF 195 200 15</b>	195	200	15.0
<b>GRF 200 205 15</b>	200	205	15.0
<b>GRF 240 245 15</b>	240	245	15.0
<b>GRF 255 260 15</b>	255	260	15.0



# GRB

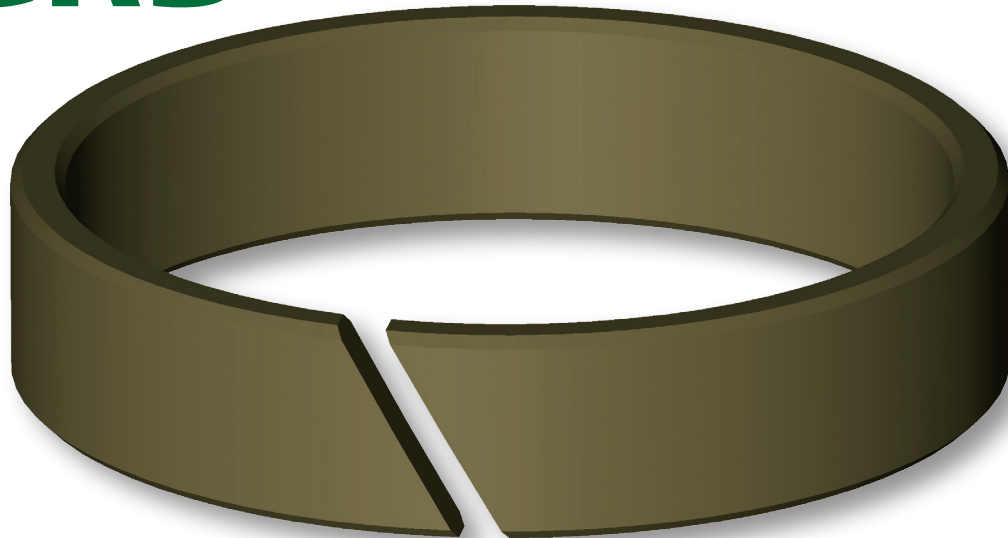

## MATERIAL

	<b>Type</b>	Polytetrafluoroethylene PTFE + Bronze
	<b>Designation</b>	SEALFLON + Bronze

## FIELD OF APPLICATION

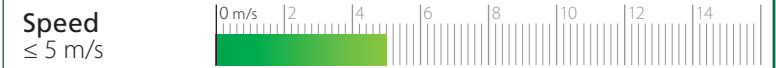

**Fluids** High compatibility with nearly all media due to the chemical resistance of the material

## SURFACE ROUGHNESS

<b>Dynamic surface</b>	Ra ≤ 0.3 μm	Rt ≤ 2.5 μm
<b>Static surface</b>	Ra ≤ 1.6 μm	Rt ≤ 6.3 μm

## CHOICE OF GUIDE RING WIDTH

A rough estimate of guide width can be calculated with the following formula:

$$h_{mm} \geq \frac{F_N \times k}{p_{N/mm^2} \times d_{mm}}$$

- where
- $h_{mm}$  • Guide ring width in mm
  - $F_N$  • Radial load in N
  - $k$  • Safety factor (generally 2)
  - $d_{mm}$  • Rod diameter in mm
  - $p_{N/mm^2}$  • Surface pressure N/mm<sup>2</sup>  
14 a 20 °C  
7 a 80 °C  
5 a 120 °C

Before assembly good cleanliness and lubrication are recommended.

The above data are maximum values, they may be maintained for short periods and can not be used at the same time simultaneously.

The Aston Seals GRB type guide rings have been developed to substitute traditional bronze guides in hydraulic cylinders. They guide the rod or the piston and prevent metallic contact with the cylinder when radial forces act perpendicular to the direction of movement.

Since GRB guide rings are machined, the thickness can be very accurate for high precision guiding.

The compound used for these guides assures an exceptional low friction and high speed performance, a high compatibility with nearly all media due to the chemical resistance which exceeds that of all other thermoplastics and elastomers.

- Low static and dynamic friction (also without lubrication)
- High speed allowed
- No tendency of stick-slip
- High precision of guiding
- Good damping on radial vibration
- High compatibility with nearly all fluids
- Simple design of groove and assembly
- Good mechanical stability at high temperature
- Easy installation without expensive auxiliaries
- Low resistance to heavy loads

# GRB

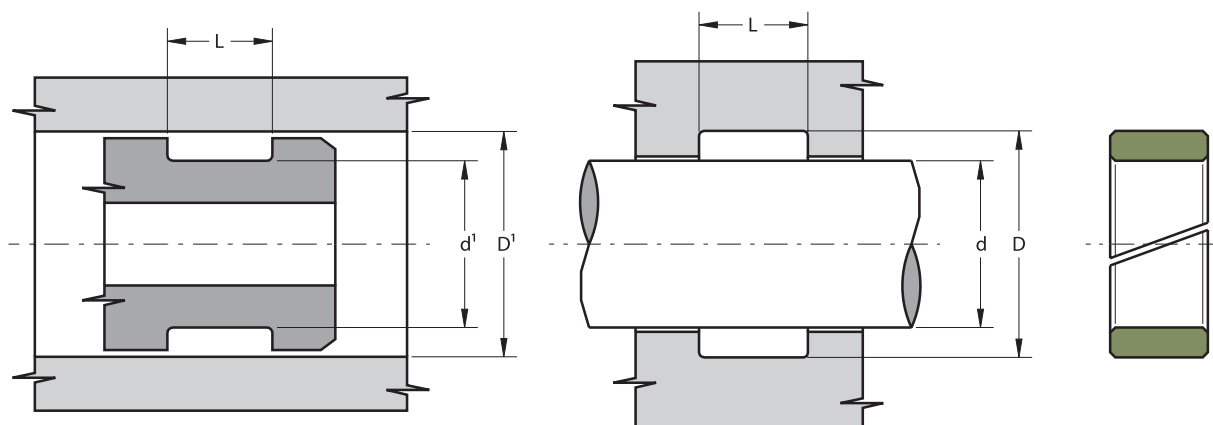

Part.	$d_1^{h8}$ $d_{f8}$	$D_1^{H9}$ $D_{H8}$	$L_{+0.2}$
GRB 15 20 6.3	15	20	6.3
GRB 20 25 6.3	20	25	6.3
GRB 25 30 6.3	25	30	6.3
GRB 30 35 6.3	30	35	6.3
GRB 30 35 8.1	30	35	8.1
GRB 30 35 9.7	30	35	9.7
GRB 35 40 6.3	35	40	6.3
GRB 35 40 8.1	35	40	8.1
GRB 35 40 9.7	35	40	9.7
GRB 40 45 6.3	40	45	6.3
GRB 40 45 8.1	40	45	8.1
GRB 40 45 9.7	40	45	9.7
GRB 40 45 15	40	45	15.0
GRB 45 50 6.3	45	50	6.3
GRB 45 50 8.1	45	50	8.1
GRB 45 50 9.7	45	50	9.7
GRB 45 50 15	45	50	15.0
GRB 50 55 6.3	50	55	6.3
GRB 50 55 8.1	50	55	8.1
GRB 50 55 9.7	50	55	9.7
GRB 50 55 15	50	55	15.0
GRB 55 60 6.3	55	60	6.3
GRB 55 60 8.1	55	60	8.1
GRB 55 60 9.7	55	60	9.7

Part.	$d_1^{h8}$ $d_{f8}$	$D_1^{H9}$ $D_{H8}$	$L_{+0.2}$
GRB 55 60 15	55	60	15.0
GRB 60 65 6.3	60	65	6.3
GRB 60 65 8.1	60	65	8.1
GRB 60 65 9.7	60	65	9.7
GRB 60 65 15	60	65	15.0
GRB 65 70 6.3	65	70	6.3
GRB 65 70 8.1	65	70	8.1
GRB 65 70 9.7	65	70	9.7
GRB 65 70 15	65	70	15.0
GRB 70 75 6.3	70	75	6.3
GRB 70 75 8.1	70	75	8.1
GRB 70 75 9.7	70	75	9.7
GRB 70 75 15	70	75	15.0
GRB 75 80 6.3	75	80	6.3
GRB 75 80 8.1	75	80	8.1
GRB 75 80 9.7	75	80	9.7
GRB 75 80 15	75	80	15.0
GRB 80 85 8.1	80	85	8.1
GRB 80 85 9.7	80	85	9.7
GRB 80 85 15	80	85	15.0
GRB 85 90 8.1	85	90	8.1
GRB 85 90 9.7	85	90	9.7
GRB 85 90 15	85	90	15.0
GRB 90 95 8.1	90	95	8.1

Part.	$d_1^{h8}$ $d_{f8}$	$D_1^{H9}$ $D_{H8}$	$L_{+0.2}$
GRB 90 95 9.7	90	95	9.7
GRB 90 95 15	90	95	15.0
GRB 95 100 8.1	95	100	8.1
GRB 95 100 9.7	95	100	9.7
GRB 95 100 15	95	100	15.0
GRB 100 105 8.1	100	105	8.1
GRB 100 105 9.7	100	105	9.7
GRB 100 105 15	100	105	15.0
GRB 105 110 8.1	105	110	8.1
GRB 105 110 9.7	105	110	9.7
GRB 105 110 15	105	110	15.0
GRB 110 115 8.1	110	115	8.1
GRB 110 115 9.7	110	115	9.7
GRB 110 115 15	110	115	15.0
GRB 115 120 8.1	115	120	8.1
GRB 115 120 9.7	115	120	9.7
GRB 115 120 15	115	120	15.0
GRB 120 125 8.1	120	125	8.1
GRB 120 125 9.7	120	125	9.7
GRB 120 125 15	120	125	15.0
GRB 125 130 8.1	125	130	8.1
GRB 125 130 9.7	125	130	9.7
GRB 125 130 15	125	130	15.0
GRB 130 135 9.7	130	135	9.7

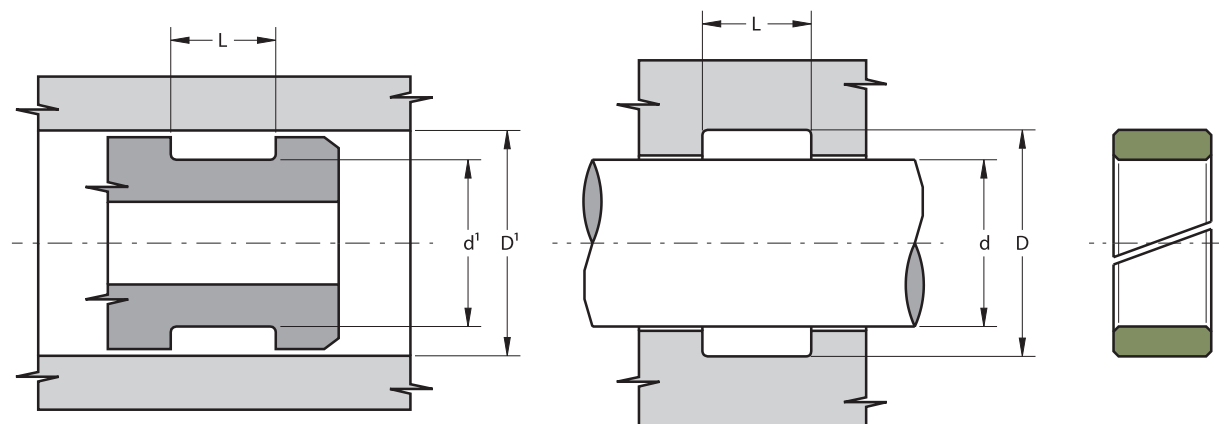

Part.	$d_1^{h8}$ $d_{f8}$	$D_1^{H9}$ $D_{H8}$	$L^{+0.2}$
<b>GRB 130 135 15</b>	130	135	15.0
<b>GRB 135 140 9.7</b>	135	140	9.7
<b>GRB 135 140 15</b>	135	140	15.0
<b>GRB 140 145 9.7</b>	140	145	9.7
<b>GRB 140 145 15</b>	140	145	15.0
<b>GRB 145 150 9.7</b>	145	150	9.7
<b>GRB 145 150 15</b>	145	150	15.0
<b>GRB 150 155 9.7</b>	150	155	9.7
<b>GRB 150 155 15</b>	150	155	15.0
<b>GRB 155 160 9.7</b>	155	160	9.7
<b>GRB 155 160 15</b>	155	160	15.0
<b>GRB 160 165 9.7</b>	160	165	9.7
<b>GRB 160 165 15</b>	160	165	15.0

Part.	$d_1^{h8}$ $d_{f8}$	$D_1^{H9}$ $D_{H8}$	$L^{+0.2}$
<b>GRB 165 170 9.7</b>	165	170	9.7
<b>GRB 165 170 15</b>	165	170	15.0
<b>GRB 170 175 9.7</b>	170	175	9.7
<b>GRB 170 175 15</b>	170	175	15.0
<b>GRB 175 180 9.7</b>	175	180	9.7
<b>GRB 175 180 15</b>	175	180	15.0
<b>GRB 180 185 9.7</b>	180	185	9.7
<b>GRB 180 185 15</b>	180	185	15.0
<b>GRB 185 190 9.7</b>	185	190	9.7
<b>GRB 185 190 15</b>	185	190	15.0
<b>GRB 190 195 15</b>	190	195	15.0
<b>GRB 195 200 15</b>	195	200	15.0



# MRB

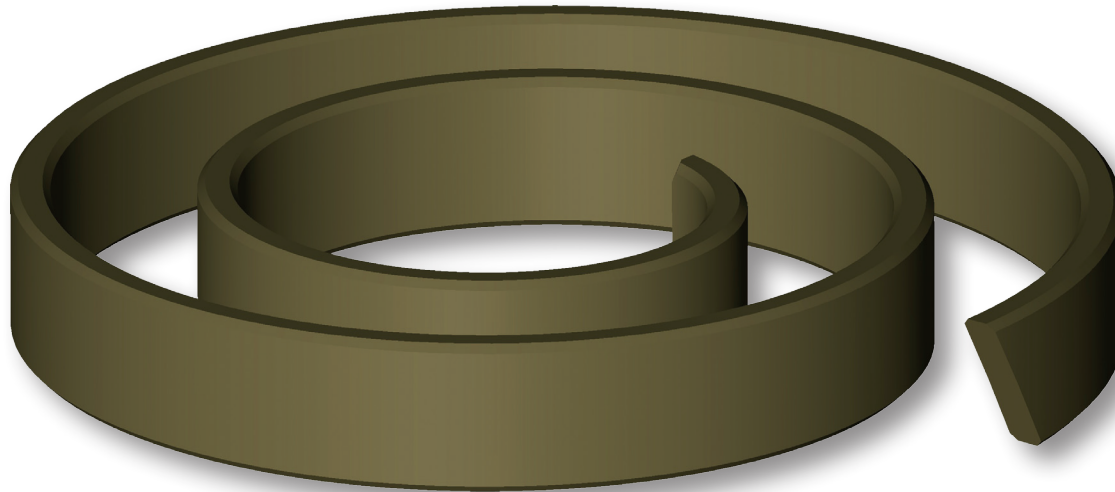

MRB

The Aston Seals MRB type guide rings have been developed to substitute traditional bronze guides in hydraulic cylinders. They guide the rod or the piston and prevent metallic contact with the cylinder when radial forces act perpendicular to the direction of movement.

Since MRB guide rings are machined, the thickness can be very accurate for high precision guiding.

The compound used for these guides assures exceptional low friction and high speed performance, high compatibility with nearly all media due to the chemical resistance which exceeds that of all other thermoplastics and elastomers.

- Low static and dynamic friction (also without lubrication)
- High speed allowed
- No tendency of stick-slip
- High precision of guiding
- Good damping on radial vibration
- High compatibility with nearly all fluids
- Simple design of groove and assembly
- Good mechanical stability at high temperature
- Easy installation without expensive auxiliaries
- Low resistance to heavy loads

## MATERIAL



Type Polytetrafluoroethylene PTFE + Bronze  
Designation SEALFLON + Bronze

## FIELD OF APPLICATION

Speed  
≤ 5 m/s



Temperature  
-50°C ÷ +200°C

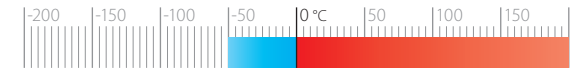

Fluids

High compatibility with nearly all media due to the chemical resistance of the material

## SURFACE ROUGHNESS

Dynamic surface  
Static surface

Ra ≤ 0.3 μm      Rt ≤ 2.5 μm  
Ra ≤ 1.6 μm      Rt ≤ 6.3 μm

## CHOICE OF GUIDE RING WIDTH

A rough estimate of guide width can be calculated with the following formula:

$$h_{mm} \geq \frac{F_N \times k}{p_{N/mm^2} \times d_{mm}}$$

where

- $h_{mm}$  • Guide ring width in mm
- $F_N$  • Radial load in N
- $k$  • Safety factor (generally 2)
- $d_{mm}$  • Rod diameter in mm
- $p_{N/mm^2}$  • Surface pressure N/mm<sup>2</sup>  
14 a 20 °C  
7 a 80 °C  
5 a 120 °C

Before assembly good cleanliness and lubrication are recommended.

The above data are maximum values, they may be maintained for short periods and can not be used at the same time simultaneously.



# MRB

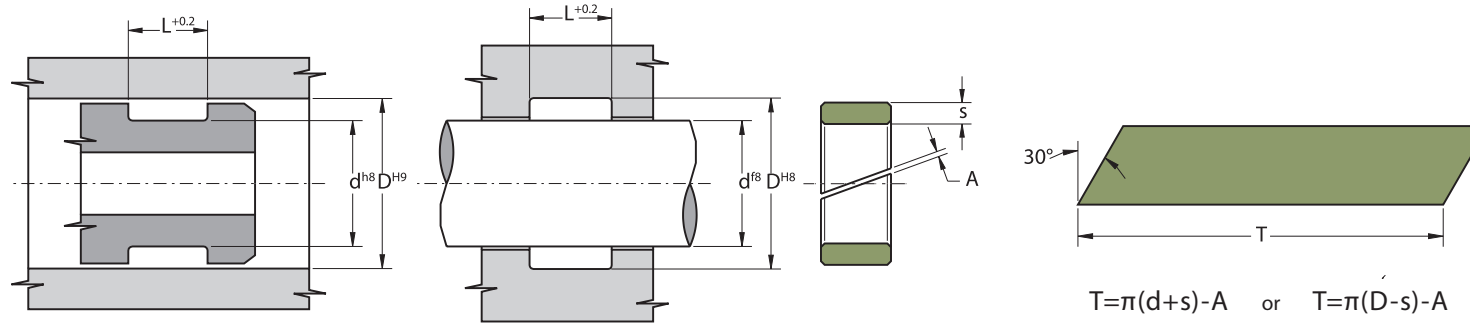

Part.	s	L	A
<b>MRB 15032</b>	1.5	3.2	1.0 ÷ 1.5
<b>MRB 15062</b>	1.5	6.2	1.5 ÷ 3.5
<b>MRB 15063</b>	1.5	6.3	1.5 ÷ 3.5
<b>MRB 15150</b>	1.5	15.0	4.0 ÷ 8.0
<b>MRB 15250</b>	1.5	25.0	6.0 ÷ 8.0
<b>MRB 20042</b>	2.0	4.2	1.0 ÷ 2.0
<b>MRB 20063</b>	2.0	6.3	1.5 ÷ 3.5
<b>MRB 20081</b>	2.0	8.1	2.0 ÷ 5.0
<b>MRB 20097</b>	2.0	9.7	2.0 ÷ 5.0
<b>MRB 20150</b>	2.0	15.0	4.0 ÷ 8.0
<b>MRB 20200</b>	2.0	20.0	4.5 ÷ 8.0
<b>MRB 20250</b>	2.0	25.0	6.0 ÷ 8.0
<b>MRB 20300</b>	2.0	30.0	6.0 ÷ 9.0
<b>MRB 25042</b>	2.5	4.2	1.0 ÷ 2.0
<b>MRB 25056</b>	2.5	5.6	1.0 ÷ 2.0
<b>MRB 25063</b>	2.5	6.3	1.5 ÷ 3.5
<b>MRB 25081</b>	2.5	8.1	2.0 ÷ 5.0

Part.	s	L	A
<b>MRB 25097</b>	2.5	9.7	2.0 ÷ 6.0
<b>MRB 25120</b>	2.5	12.0	2.0 ÷ 6.0
<b>MRB 25125</b>	2.5	12.5	2.0 ÷ 6.0
<b>MRB 25128</b>	2.5	12.8	2.0 ÷ 6.0
<b>MRB 25150</b>	2.5	15.0	4.0 ÷ 8.0
<b>MRB 25200</b>	2.5	20.0	4.5 ÷ 8.0
<b>MRB 25250</b>	2.5	25.0	6.0 ÷ 8.0
<b>MRB 25300</b>	2.5	30.0	6.0 ÷ 9.0
<b>MRB 30097</b>	3.0	9.7	2.0 ÷ 6.0
<b>MRB 30128</b>	3.0	12.8	2.0 ÷ 6.0
<b>MRB 30150</b>	3.0	15.0	4.0 ÷ 8.0
<b>MRB 30192</b>	3.0	19.2	4.0 ÷ 8.0
<b>MRB 30200</b>	3.0	20.0	4.5 ÷ 8.0
<b>MRB 30250</b>	3.0	25.0	6.0 ÷ 8.0
<b>MRB 30300</b>	3.0	30.0	6.0 ÷ 9.0
<b>MRB 30350</b>	3.0	35.0	6.0 ÷ 9.0
<b>MRB 30400</b>	3.0	40.0	6.0 ÷ 9.0

# FSP

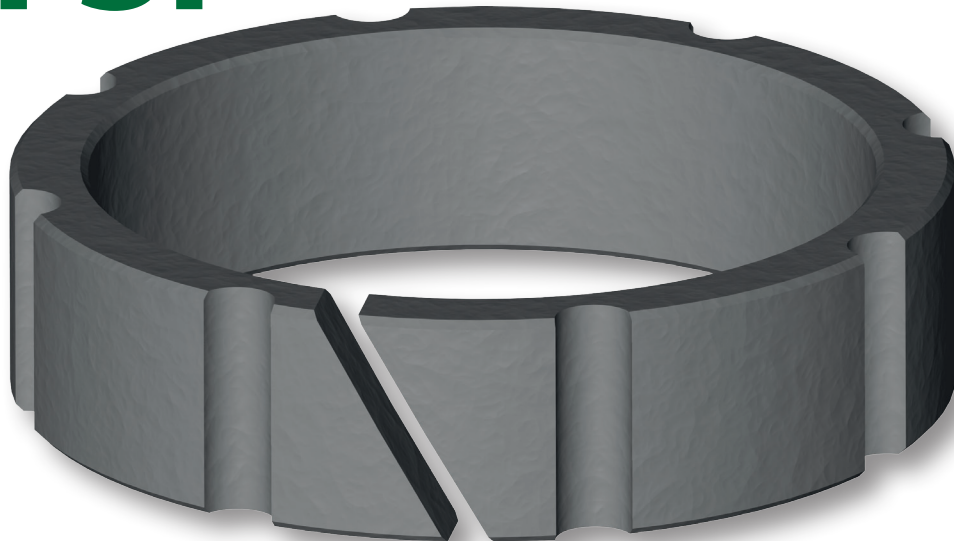

## MATERIAL



Type Acetal resin with glass fibre  
 Designation BEARITE

## FIELD OF APPLICATION



Fluids Hydraulic oils (mineral oil based)  
 For other fluids contact our technical department

## SURFACE ROUGHNESS

Dynamic surface	$R_a \leq 0.3 \mu\text{m}$	$R_t \leq 2.5 \mu\text{m}$
Static surface	$R_a \leq 2 \mu\text{m}$	$R_t \leq 10 \mu\text{m}$

## CHOICE OF GUIDE RING WIDTH

A rough estimate of guide width can be calculated with the following formula:

$$h_{mm} \geq \frac{F_N \times k}{p_{N/mm^2} \times d_{mm}}$$

- where
- $h_{mm}$  • Guide ring width in mm
  - $F_N$  • Radial load in N
  - $k$  • Safety factor (generally 2)
  - $d_{mm}$  • Rod diameter in mm
  - $p_{N/mm^2}$  • Surface pressure N/mm<sup>2</sup>  
 40 a 20 °C  
 30 a 70 °C

Before assembly good cleanliness and lubrication are recommended.

The above data are maximum values, they may be maintained for short periods and can not be used at the same time simultaneously.

The guide rings type Aston Seals FSP have been realized to substitute traditional bronze guide in hydraulic cylinders.

They guide the rod of a plunger cylinder where, thanks to the big longitudinal grooves on the outside surface, an overflow of the fluid is continuously assured.

The compound used for these guides is a medium viscosity acetal resin glass fibre reinforced characterized by high strength, rigidity, hardness, impact resistance, resilience and excellent stability to high and low temperature.

- Simple design of groove and assembly
- Low friction
- Good resistance to loads
- Good mechanical stability at high temperature
- Easy installation without expensive auxiliaries

- Extended service life
- Excellent wear-resistance

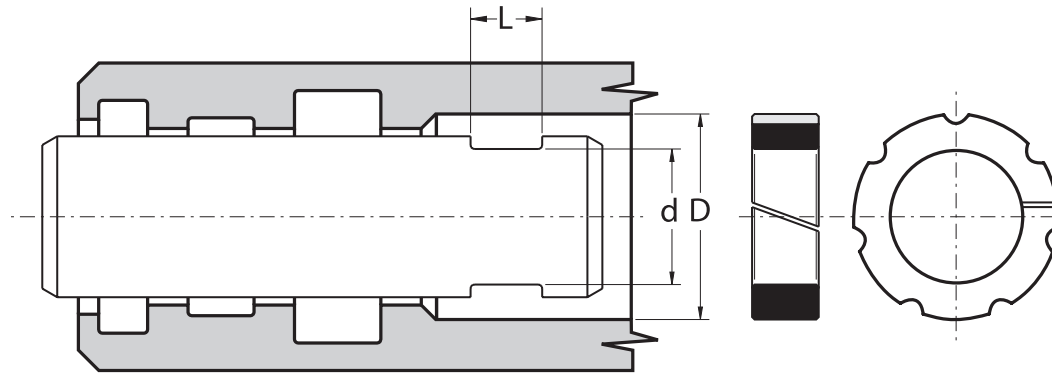

Part.	D <sup>H8</sup>	d <sup>-0.05</sup>	L <sup>+0.5</sup>
<b>FSP 25 16 12</b>	25	16	13.0
<b>FSP 30 20 12</b>	30	20	13.0
<b>FSP 33.5 24.5 12</b>	33.5	24.5	13.0
<b>FSP 35 25 12</b>	35	25	13.0
<b>FSP 40 30 12</b>	40	30	13.0
<b>FSP 42 32 12</b>	42	32	13.0
<b>FSP 45 35 12</b>	45	35	13.0
<b>FSP 49 41 8</b>	49	41	9.0
<b>FSP 49.9 40.92 11.7</b>	49.9	40.92	12.7
<b>FSP 50 40 15</b>	50	40	16.0
<b>FSP 54.5 45 19</b>	54.5	45	20.0
<b>FSP 55 45 15</b>	55	45	16.0
<b>FSP 60 45 15</b>	60	45	16.0
<b>FSP 60 50 15</b>	60	50	16.0

Part.	D <sup>H8</sup>	d <sup>-0.05</sup>	L <sup>+0.5</sup>
<b>FSP 65 55 15</b>	65	55	16.0
<b>FSP 65 57 8</b>	65	57	9.0
<b>FSP 70 60 19</b>	70	60	20.0
<b>FSP 75 65 12</b>	75	65	13.0
<b>FSP 75 65 15</b>	75	65	16.0
<b>FSP 80 71 10</b>	80	71	11.0
<b>FSP 85 75 15</b>	85	75	16.0
<b>FSP 92 83 10</b>	92	83	11.0
<b>FSP 95 86 10</b>	95	86	11.0
<b>FSP 100 90 15</b>	100	90	16.0
<b>FSP 112 102 12</b>	112	102	13.0
<b>FSP 120 110 15</b>	120	110	16.0
<b>FSP 131 121 14</b>	131	121	15.0
<b>FSP 152 140 16</b>	152	140	17.0

# OR



### MATERIAL

	<b>Type</b> Nitril Rubber NBR	<b>Designation</b> RUBSEAL 70	<b>Hardness</b> 70 °ShA
--	----------------------------------	----------------------------------	----------------------------

### CODING

Usually the O-Ring is defined by a regulation (such as AS 568A or BS 1806) or by:  
 - inside diameter  
 - diameter of cross section

### FIELD OF APPLICATION

<b>Pressure</b>	See table below
<b>Speed</b>	Depending of working condition. It is preferable as static seal
<b>Temperature</b> -30°C ÷ +130°C	
<b>Fluids</b>	Hydraulic oils (mineral oil based) For other fluids contact our technical department

### MAX. PRESSURE

In order to avoid extrusion, the maximum pressure allowed depends on the fitting gap:

0,05 mm	190 bar	0,25 mm	90 bar
0,10 mm	130 bar	0,30 mm	80 bar
0,15 mm	110 bar	0,35 mm	75 bar
0,20 mm	100 bar		

NB: for the Gap calculation, it is necessary to consider the elastic deformation of metal elements under pressure loads.

### SURFACE ROUGHNESS

<b>Dynamic surface</b>	Ra ≤ 0.8 µm	Rt ≤ 4.8 µm
<b>Static surface</b>	Ra ≤ 0.3 µm	Rt ≤ 2.5 µm

To avoid damaging the sealing lips during installation, housing must have rounded chamfers. Sharp edges and burrs within the installation area of the seal must be removed.

The above data are maximum values, they may be maintained for short periods and can not be used at the same time simultaneously.

The Aston Seals O-Rings have been developed to be used as static (preferable) or as dynamic seals in a rectangular groove.

They are energized by pressure and can work as a single or double acting sealing element. The radial sealing forces, which guarantee good sealing performance, increase when the pressure rises.

Thanks to its elasticity, it can be installed very easily in a short time and without any auxiliaries.

The material used is a low permanent deformation nitril rubber with 70 °ShA of hardness, mainly used in the manufacturing of hydraulic seals.

- Low cost solution
- Universal applicability
- Single and double acting
- Simple groove design
- No close tolerances are necessary
- Symmetrical cross section
- Easy installation without expensive auxiliaries

# OR

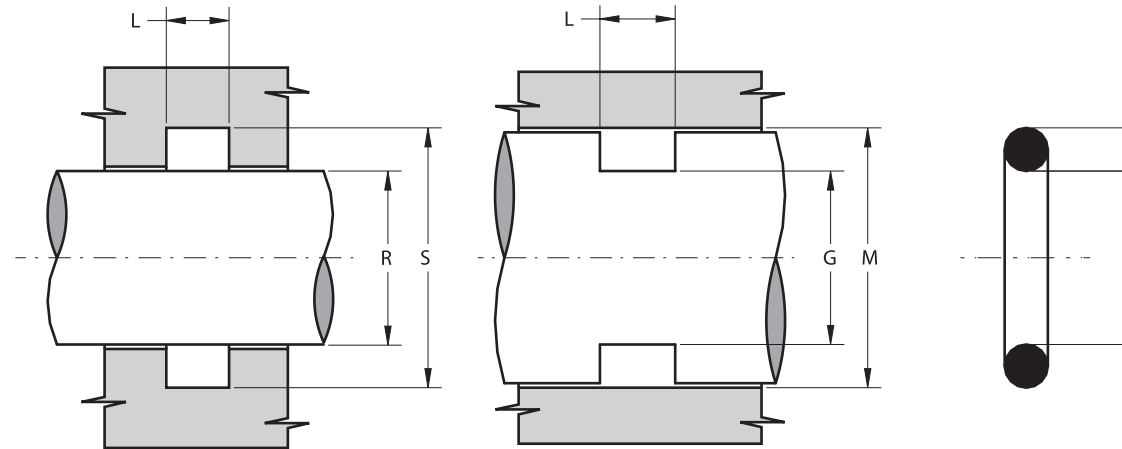

Cod. AS*	Cod. GB	d	c	L <sup>+0.2</sup>	R <sup>f7</sup>	S <sup>H9</sup>	G <sup>H9</sup>	M <sup>H8</sup>
OR 004	2007	1.78	1.78	2.5	2	5.1	1.9	5
OR 005	2010	2.57	1.78	2.5	2.5	5.6	2.9	6
OR 006	2012	2.90	1.78	2.5	3	6.1	2.9	6
OR 007	2015	3.68	1.78	2.5	4	7.1	3.9	7
OR 008	2018	4.47	1.78	2.5	4.5	7.6	4.9	8
OR 009	2021	5.28	1.78	2.5	5	8.1	5.9	9
OR 010	2025	6.07	1.78	2.5	6	9.1	6.9	10
OR 610	106	6.75	1.78	2.5	7	10.1	6.9	10
OR 011	2031	7.65	1.78	2.5	8	11.1	7.9	11
OR 611	108	8.73	1.78	2.5	9	12.1	8.9	12
OR 012	2037	9.25	1.78	2.5	9	12.1	9.9	13
OR 013	2043	10.82	1.78	2.5	11	14.1	10.9	14
OR 806	114	11.11	1.78	2.5	11	14.1	11.9	15
OR 014	2050	12.42	1.78	2.5	13	16.1	12.9	16
OR 015	2056	14.00	1.78	2.5	14	17.1	14.9	18
OR 016	2062	15.60	1.78	2.5	16	19.1	15.9	19
OR 017	2068	17.17	1.78	2.5	17	20.1	17.9	21
OR 018	2075	18.77	1.78	2.5	19	22.1	18.9	22
OR 019	2081	20.35	1.78	2.5	21	24.1	20.9	24
OR 020	2087	21.95	1.78	2.5	22	25.1	22.9	26
OR 021	2093	23.52	1.78	2.5	24	27.1	23.9	27
OR 022	2100	25.12	1.78	2.5	25	28.1	25.9	29

Cod. AS*	Cod. GB	d	c	L <sup>+0.2</sup>	R <sup>f7</sup>	S <sup>H9</sup>	G <sup>H9</sup>	M <sup>H8</sup>
OR 023	2106	26.70	1.78	2.5	27	30.1	26.9	30
OR 024	2112	28.30	1.78	2.5	28	31.1	28.9	32
OR 025	2118	29.87	1.78	2.5	30	33.1	29.9	33
OR 026	2125	31.47	1.78	2.5	32	35.1	31.9	35
OR 027	2131	33.05	1.78	2.5	33	36.1	33.9	37
OR 028	2137	34.65	1.78	2.5	35	38.1	34.9	38
OR 029	2150	37.82	1.78	2.5	38	41.1	37.9	41
OR 030	2162	41.00	1.78	2.5	41	44.1	41.9	45
OR 031	2175	44.17	1.78	2.5	44	47.1	44.9	48
OR 032	2187	47.35	1.78	2.5	48	51.1	47.9	51
OR 033	2200	50.52	1.78	2.5	50	53.1	50.9	54
OR 034	2212	53.70	1.78	2.5	54	57.1	54.9	58
OR 035	2225	56.87	1.78	2.5	57	60.1	57.9	61
OR 036	2237	60.05	1.78	2.5	60	63.1	60.9	64
OR 037	2250	63.22	1.78	2.5	63	66.1	63.9	67
OR 038	2262	66.40	1.78	2.5	66	69.1	66.9	70
OR 039	2275	69.57	1.78	2.5	70	73.1	70.9	74
OR 040	2287	72.75	1.78	2.5	73	76.1	73.9	77
OR 041	2300	75.92	1.78	2.5	76	79.1	76.9	80
OR 042	2325	82.27	1.78	2.5	82	85.1	82.9	86
OR 043	2350	88.62	1.78	2.5	89	92.1	88.9	92
OR 044	2375	94.97	1.78	2.5	95	98.1	95.9	99

\* according to AS 568 A regulation

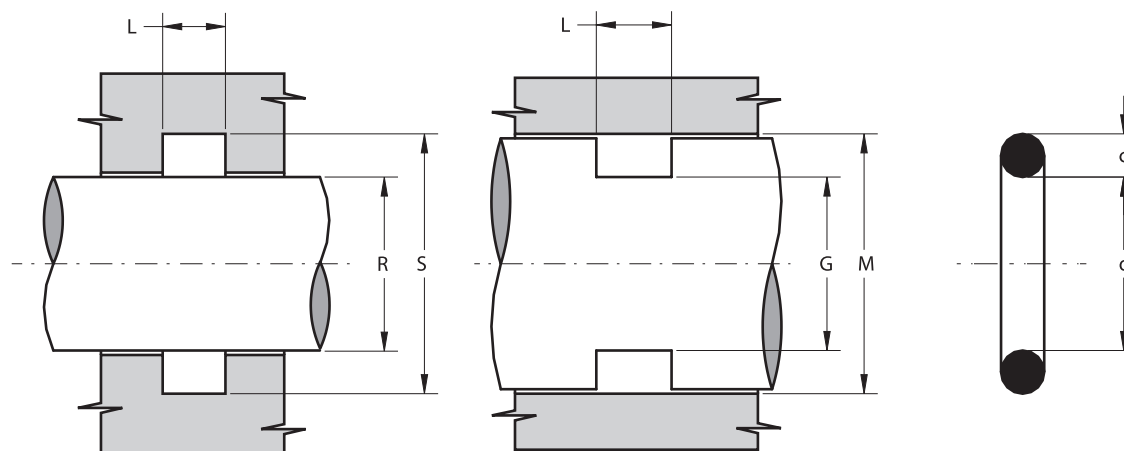

Cod. AS*	Cod. GB	d	c	L <sup>+0.2</sup>	R <sup>f7</sup>	S <sup>H9</sup>	G <sup>h9</sup>	M <sup>H8</sup>
<b>OR 045</b>	2400	101.32	1.78	2.5	101	104.1	101.9	105
<b>OR 046</b>	2425	107.67	1.78	2.5	108	111.1	108.9	112
<b>OR 047</b>	2450	114.02	1.78	2.5	114	117.1	114.9	118
<b>OR 048</b>	2475	120.37	1.78	2.5	120	123.1	120.9	124
<b>OR 049</b>	2500	126.72	1.78	2.5	125	128.1	125.9	129
<b>OR 050</b>	2525	133.07	1.78	2.5	133	136.1	133.9	137
<b>OR 107</b>	-	5.23	2.62	3.5	5.5	10	6	10.5
<b>OR 108</b>	-	6.02	2.62	3.5	6	10.5	6.5	11
<b>OR 109</b>	-	7.60	2.62	3.5	8	12.5	8.5	13
<b>OR 110</b>	3037	9.19	2.62	3.5	9	13.5	10.5	15
<b>OR 613</b>	112	9.92	2.62	3.5	10	14.5	10.5	15
<b>OR 111</b>	3043	10.77	2.62	3.5	11	15.5	11.5	16
<b>OR 614</b>	115	11.91	2.62	3.5	12	16.5	12.5	17
<b>OR 112</b>	3050	12.37	2.62	3.5	12.5	17	13.5	18
<b>OR 615</b>	117	13.10	2.62	3.5	13	17.5	13.5	18
<b>OR 113</b>	3056	13.94	2.62	3.5	14	18.5	14.5	19
<b>OR 616</b>	119	15.08	2.62	3.5	15	19.5	15.5	20
<b>OR 114</b>	3062	15.54	2.62	3.5	15.5	20	16.5	21
<b>OR 809</b>	121	15.88	2.62	3.5	16	20.5	16.5	21
<b>OR 115</b>	3068	17.12	2.62	3.5	17	21.5	17.5	22
<b>OR 617</b>	123	17.86	2.62	3.5	18	22.5	18.5	23

Cod. AS*	Cod. GB	d	c	L <sup>+0.2</sup>	R <sup>f7</sup>	S <sup>H9</sup>	G <sup>h9</sup>	M <sup>H8</sup>
<b>OR 116</b>	3075	18.72	2.62	3.5	19	23.5	19.5	24
<b>OR 117</b>	3081	20.29	2.62	3.5	20	24.5	20.5	25
<b>OR 812</b>	128	20.63	2.62	3.5	21	25.5	21.5	26
<b>OR 118</b>	3087	21.89	2.62	3.5	22	26.5	22.5	27
<b>OR 813</b>	130	22.22	2.62	3.5	22	26.5	22.5	27
<b>OR 119</b>	3093	23.47	2.62	3.5	24	28.5	24.5	29
<b>OR 814</b>	132	23.81	2.62	3.5	24	28.5	24.5	29
<b>OR 120</b>	3100	25.07	2.62	3.5	25	29.5	25.5	30
<b>OR 121</b>	3106	26.64	2.62	3.5	27	31.5	27.5	32
<b>OR 122</b>	3112	28.24	2.62	3.5	28	32.5	28.5	33
<b>OR 123</b>	3118	29.82	2.62	3.5	30	34.5	30.5	35
<b>OR 124</b>	3125	31.42	2.62	3.5	32	36.5	32.5	37
<b>OR 125</b>	3131	32.99	2.62	3.5	33	37.5	33.5	38
<b>OR 126</b>	3137	34.60	2.62	3.5	35	39.5	35.5	40
<b>OR 127</b>	3143	36.14	2.62	3.5	36	40.5	36.5	41
<b>OR 128</b>	3150	37.77	2.62	3.5	38	42.5	38.5	43
<b>OR 129</b>	3156	39.34	2.62	3.5	40	44.5	40.5	45
<b>OR 130</b>	3162	40.95	2.62	3.5	41	45.5	41.5	46
<b>OR 131</b>	3168	42.52	2.62	3.5	43	47.5	43.5	48
<b>OR 132</b>	3175	44.12	2.62	3.5	44	48.5	44.5	49
<b>OR 133</b>	3181	45.69	2.62	3.5	46	50.5	46.5	51
<b>OR 134</b>	3187	47.30	2.62	3.5	48	52.5	48.5	53

\* according to AS 568 A regulation

# OR

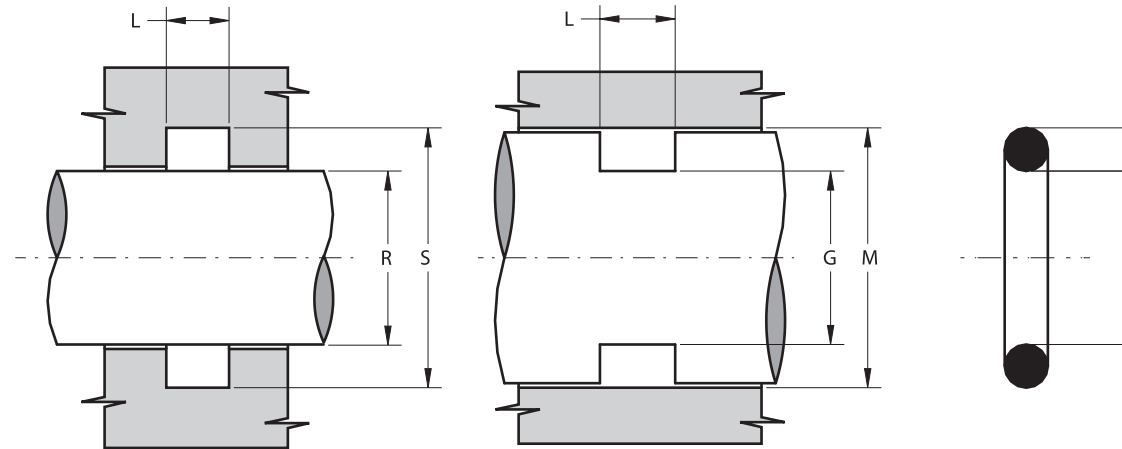

Cod. AS*	Cod. GB	d	c	L <sup>+0.2</sup>	R <sup>f7</sup>	S <sup>H9</sup>	G <sup>H9</sup>	M <sup>H8</sup>
OR 135	3193	48.90	2.62	3.5	49	53.5	49.5	54
OR 136	3200	50.47	2.62	3.5	51	55.5	51.5	56
OR 137	3206	52.07	2.62	3.5	52	56.5	52.5	57
OR 138	3212	53.65	2.62	3.5	54	58.5	54.5	59
OR 139	3218	55.25	2.62	3.5	55	59.5	56.5	61
OR 140	3225	56.82	2.62	3.5	57	61.5	57.5	62
OR 141	3231	58.42	2.62	3.5	59	63.5	59.5	64
OR 142	3237	60.00	2.62	3.5	60	64.5	60.5	65
OR 143	3243	61.60	2.62	3.5	62	66.5	62.5	67
OR 144	3250	63.17	2.62	3.5	63	67.5	63.5	68
OR 145	3256	64.77	2.62	3.5	65	69.5	65.5	70
OR 146	3262	66.35	2.62	3.5	67	71.5	67.5	72
OR 147	3268	67.95	2.62	3.5	68	72.5	68.5	73
OR 148	3275	69.52	2.62	3.5	70	74.5	70.5	75
OR 149	3281	71.12	2.62	3.5	71	75.5	71.5	76
OR 150	3287	72.69	2.62	3.5	73	77.5	73.5	78
OR 151	3300	75.87	2.62	3.5	76	80.5	77.5	82
OR 152	3325	82.22	2.62	3.5	82	86.5	83.5	88
OR 153	3350	88.57	2.62	3.5	89	93.5	89.5	94
OR 154	3375	94.92	2.62	3.5	95	99.5	96.5	101
OR 155	3400	101.27	2.62	3.5	101	105.5	102.5	107
OR 156	3425	107.62	2.62	3.5	108	112.5	108.5	113

Cod. AS*	Cod. GB	d	c	L <sup>+0.2</sup>	R <sup>f7</sup>	S <sup>H9</sup>	G <sup>H9</sup>	M <sup>H8</sup>
OR 157	3450	113.97	2.62	3.5	114	118.5	115.5	120
OR 158	3475	120.33	2.62	3.5	120	124.5	121.5	126
OR 159	3500	126.67	2.62	3.5	127	131.5	127.5	132
OR 160	3525	133.00	2.62	3.5	133	137.5	133.5	138
OR 161	3550	139.38	2.62	3.5	139	143.5	140.5	145
OR 162	3575	145.72	2.62	3.5	146	150.5	146.5	151
OR 163	3600	152.07	2.62	3.5	152	156.5	153.5	158
OR 164	3625	158.43	2.62	3.5	158	162.5	159.5	164
OR 165	3650	164.78	2.62	3.5	165	169.5	165.5	170
OR 166	3675	171.13	2.62	3.5	171	175.5	172.5	177
OR 167	3700	177.48	2.62	3.5	178	182.5	178.5	183
OR 168	3725	183.83	2.62	3.5	184	188.5	185.5	190
OR 169	3750	190.18	2.62	3.5	190	194.5	191.5	196
OR 170	3775	196.53	2.62	3.5	197	201.5	197.5	202
OR 171	3800	202.88	2.62	3.5	203	207.5	204.5	209
OR 172	3825	209.23	2.62	3.5	210	214.5	210.5	215
OR 173	3850	215.58	2.62	3.5	215	219.5	215.5	220
OR 174	3875	221.93	2.62	3.5	222	226.5	223.5	228
OR 175	3900	228.28	2.62	3.5	228	232.5	229.5	234
OR 204	4036	9.12	3.53	4.5	10	16.2	10.8	17
OR 205	4042	10.69	3.53	4.5	11	17.2	11.8	18

\* according to AS 568 A regulation

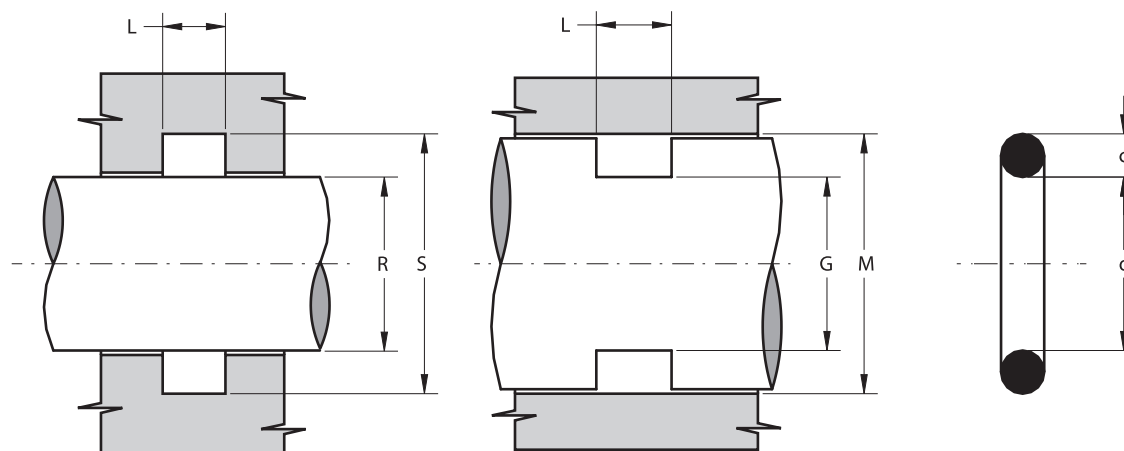

Cod. AS*	Cod. GB	d	c	L <sup>+0.2</sup>	R <sup>f7</sup>	S <sup>H9</sup>	G <sup>h9</sup>	M <sup>H8</sup>
<b>OR 206</b>	4050	12.29	3.53	4.5	13	19.2	13.8	20
<b>OR 207</b>	4055	13.87	3.53	4.5	14	20.2	14.8	21
<b>OR 208</b>	4061	15.47	3.53	4.5	16	22.2	16.8	23
<b>OR 209</b>	4067	17.04	3.53	4.5	17	23.2	18.8	25
<b>OR 210</b>	4075	18.64	3.53	4.5	19	25.2	19.8	26
<b>OR 211</b>	4081	20.22	3.53	4.5	20	26.2	21.8	28
<b>OR 212</b>	4087	21.82	3.53	4.5	22	28.2	22.8	29
<b>OR 213</b>	4093	23.40	3.53	4.5	23	29.2	23.8	30
<b>OR 214</b>	4100	24.99	3.53	4.5	25	31.2	25.8	32
<b>OR 618</b>	134	25.80	3.53	4.5	26	32.2	26.8	33
<b>OR 215</b>	4106	26.58	3.53	4.5	27	33.2	27.8	34
<b>OR 216</b>	4112	28.17	3.53	4.5	28	34.2	28.8	35
<b>OR 217</b>	4118	29.75	3.53	4.5	30	36.2	30.8	37
<b>OR 218</b>	4125	31.34	3.53	4.5	31	37.2	31.8	38
<b>OR 219</b>	4131	32.92	3.53	4.5	33	39.2	33.8	40
<b>OR 220</b>	4137	34.52	3.53	4.5	35	41.2	35.8	42
<b>OR 221</b>	4143	36.09	3.53	4.5	36	42.2	36.8	43
<b>OR 222</b>	4150	37.69	3.53	4.5	38	44.2	38.8	45
<b>OR 824</b>	144	39.69	3.53	4.5	40	46.2	39.8	46
<b>OR 223</b>	4162	40.87	3.53	4.5	42	48.2	41.8	48
<b>OR 825</b>	146	41.28	3.53	4.5	42	48.2	41.8	48
<b>OR 826</b>	147	42.86	3.53	4.5	43	49.2	43.8	50

Cod. AS*	Cod. GB	d	c	L <sup>+0.2</sup>	R <sup>f7</sup>	S <sup>H9</sup>	G <sup>h9</sup>	M <sup>H8</sup>
<b>OR 224</b>	4175	44.04	3.53	4.5	45	51.2	44.8	51
<b>OR 827</b>	149	44.45	3.53	4.5	45	51.2	44.8	51
<b>OR 828</b>	150	46.04	3.53	4.5	46	52.2	46.8	53
<b>OR 225</b>	4187	47.22	3.53	4.5	48	54.2	47.8	54
<b>OR 829</b>	152	47.63	3.53	4.5	48	54.2	47.8	54
<b>OR 830</b>	153	49.21	3.53	4.5	49	55.2	49.8	56
<b>OR 226</b>	4200	50.39	3.53	4.5	51	57.2	51.8	58
<b>OR 831</b>	155	50.80	3.53	4.5	51	57.2	51.8	58
<b>OR 832</b>	156	52.39	3.53	4.5	52	58.2	53.8	60
<b>OR 227</b>	4212	53.57	3.53	4.5	54	60.2	54.8	61
<b>OR 833</b>	158	53.98	3.53	4.5	54	60.2	54.8	61
<b>OR 834</b>	159	55.56	3.53	4.5	56	62.2	55.8	62
<b>OR 228</b>	4225	56.74	3.53	4.5	57	63.2	57.8	64
<b>OR 835</b>	161	57.15	3.53	4.5	57	63.2	57.8	64
<b>OR 836</b>	162	58.74	3.53	4.5	59	65.2	58.8	65
<b>OR 229</b>	4237	59.92	3.53	4.5	60	66.2	60.8	67
<b>OR 837</b>	164	60.33	3.53	4.5	60	66.2	60.8	67
<b>OR 838</b>	165	61.91	3.53	4.5	62	68.2	62.8	69
<b>OR 230</b>	4250	63.09	3.53	4.5	64	70.2	63.8	70
<b>OR 839</b>	167	63.50	3.53	4.5	64	70.2	63.8	70
<b>OR 840</b>	168	65.09	3.53	4.5	65	71.2	65.8	72
<b>OR 231</b>	4262	66.27	3.53	4.5	67	73.2	66.8	73

\* according to AS 568 A regulation



# OR

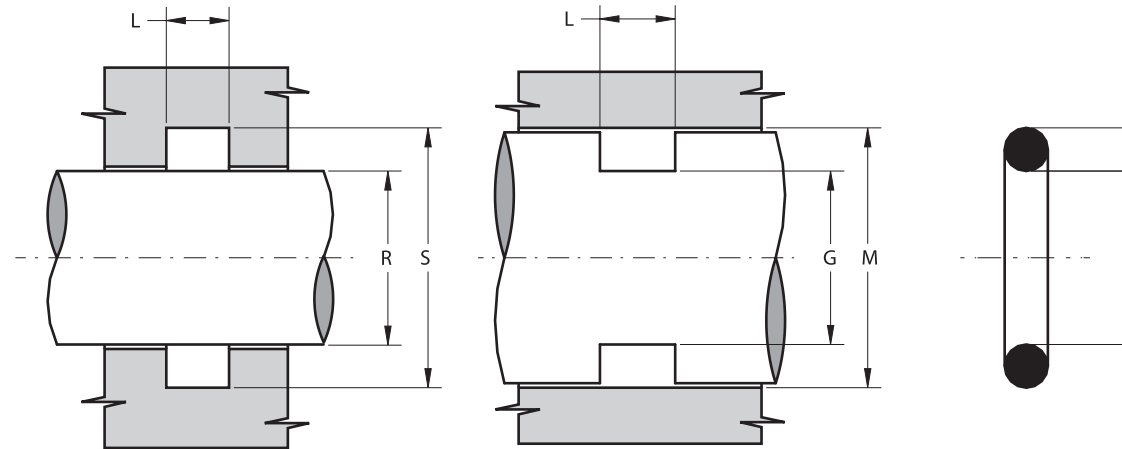

Cod. AS*	Cod. GB	d	c	L <sup>+0.2</sup>	R <sup>f7</sup>	S <sup>H9</sup>	G <sup>H9</sup>	M <sup>H8</sup>
OR 841	170	66.68	3.53	4.5	67	73.2	66.8	73
OR 842	171	68.26	3.53	4.5	68	74.2	68.8	75
OR 232	4275	69.44	3.53	4.5	70	76.2	70.8	77
OR 843	173	69.85	3.53	4.5	70	76.2	70.8	77
OR 844	174	71.44	3.53	4.5	72	78.2	71.8	78
OR 233	4287	72.62	3.53	4.5	73	79.2	73.8	80
OR 845	176	73.03	3.53	4.5	73	79.2	73.8	80
OR 846	177	74.61	3.53	4.5	75	81.2	74.8	81
OR 234	4300	75.79	3.53	4.5	76	82.2	76.8	83
OR 235	4312	78.97	3.53	4.5	79	85.2	79.8	86
OR 236	4325	82.14	3.53	4.5	82	88.2	82.8	89
OR 237	4337	85.32	3.53	4.5	85	91.2	85.8	92
OR 238	4350	88.49	3.53	4.5	89	95.2	88.8	95
OR 239	4362	91.67	3.53	4.5	92	98.2	92.8	99
OR 240	4375	94.84	3.53	4.5	95	101.2	95.8	102
OR 241	4387	98.02	3.53	4.5	98	104.2	98.8	105
OR 242	4400	101.19	3.53	4.5	101	107.2	101.8	108
OR 243	4412	104.37	3.53	4.5	105	111.2	104.8	111
OR 244	4425	107.54	3.53	4.5	108	114.2	107.8	114
OR 245	4437	110.72	3.53	4.5	111	117.2	111.8	118
OR 246	4450	113.89	3.53	4.5	114	120.2	114.8	121
OR 247	4462	117.07	3.53	4.5	117	123.2	117.8	124

Cod. AS*	Cod. GB	d	c	L <sup>+0.2</sup>	R <sup>f7</sup>	S <sup>H9</sup>	G <sup>H9</sup>	M <sup>H8</sup>
OR 248	4475	120.24	3.53	4.5	120	126.2	120.8	127
OR 249	4487	123.42	3.53	4.5	123	129.2	123.8	130
OR 250	4500	126.59	3.53	4.5	127	133.2	126.8	133
OR 251	4512	129.77	3.53	4.5	130	136.2	129.8	136
OR 252	4525	132.94	3.53	4.5	133	139.2	133.8	140
OR 253	4537	136.12	3.53	4.5	136	142.2	136.8	143
OR 254	4550	139.29	3.53	4.5	140	146.2	139.8	146
OR 255	4562	142.47	3.53	4.5	143	149.2	142.8	149
OR 256	4575	145.64	3.53	4.5	146	152.2	145.8	152
OR 257	4587	148.82	3.53	4.5	149	155.2	148.8	155
OR 258	4600	151.99	3.53	4.5	152	158.2	152.8	159
OR 259	4625	158.34	3.53	4.5	159	165.2	158.8	165
OR 260	4650	164.69	3.53	4.5	165	171.2	165.8	172
OR 261	4675	171.04	3.53	4.5	172	178.2	171.8	178
OR 262	4700	177.39	3.53	4.5	178	184.2	177.8	184
OR 263	4725	183.74	3.53	4.5	184	190.2	183.8	190
OR 264	4750	190.09	3.53	4.5	190	196.2	190.8	197
OR 265	4775	196.44	3.53	4.5	197	203.2	196.8	203
OR 266	4800	202.79	3.53	4.5	203	209.2	203.8	210
OR 267	4825	209.14	3.53	4.5	210	216.2	209.8	216
OR 268	4850	215.49	3.53	4.5	216	222.2	215.8	222
OR 269	4875	221.84	3.53	4.5	222	228.2	221.8	228

\* according to AS 568 A regulation

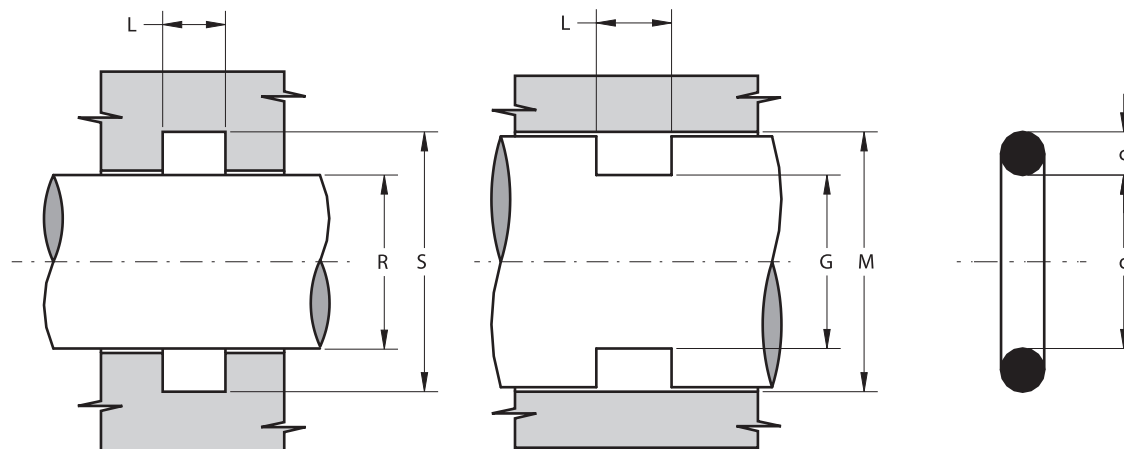

Cod. AS*	Cod. GB	d	c	L <sup>+0.2</sup>	R <sup>f7</sup>	S <sup>H9</sup>	G <sup>H9</sup>	M <sup>H8</sup>
<b>OR 270</b>	4900	228.19	3.53	4.5	229	235.2	228.8	235
<b>OR 271</b>	4925	234.54	3.53	4.5	235	241.2	234.8	241
<b>OR 272</b>	4950	240.89	3.53	4.5	241	247.2	241.8	248
<b>OR 273</b>	4975	247.24	3.53	4.5	248	254.2	247.8	254
<b>OR 274</b>	41000	253.59	3.53	4.5	254	260.2	253.8	260
<b>OR 275</b>	41050	266.29	3.53	4.5	267	273.2	267.8	274
<b>OR 276</b>	41100	278.99	3.53	4.5	280	286.2	280.8	287
<b>OR 277</b>	41150	291.69	3.53	4.5	292	298.2	293.8	300
<b>OR 278</b>	41200	304.39	3.53	4.5	305	311.2	305.8	312
<b>OR 279</b>	41300	329.79	3.53	4.5	330	336.2	331.8	338
<b>OR 280</b>	41400	355.19	3.53	4.5	355	361.2	356.8	363
<b>OR 281</b>	41500	380.59	3.53	4.5	381	387.2	382.8	389
<b>OR 282</b>	41600	405.26	3.53	4.5	406	412.2	406.8	413
<b>OR 283</b>	41700	430.66	3.53	4.5	431	437.2	431.8	438
<b>OR 309</b>	-	10.47	5.34	7	11	20.4	12.6	22
<b>OR 310</b>	-	12.07	5.34	7	12	21.4	13.6	23
<b>OR 311</b>	-	13.64	5.34	7	14	23.4	15.6	25
<b>OR 312</b>	-	15.24	5.34	7	16	25.4	16.6	26
<b>OR 313</b>	-	16.82	5.34	7	17	26.4	18.6	28
<b>OR 314</b>	-	18.42	5.34	7	19	28.4	20.6	30
<b>OR 315</b>	-	19.99	5.34	7	20	29.4	21.6	31

Cod. AS*	Cod. GB	d	c	L <sup>+0.2</sup>	R <sup>f7</sup>	S <sup>H9</sup>	G <sup>H9</sup>	M <sup>H8</sup>
<b>OR 316</b>	-	21.99	5.34	7	22	31.4	23.6	33
<b>OR 317</b>	-	23.17	5.34	7	24	33.4	24.6	34
<b>OR 318</b>	-	24.77	5.34	7	26	35.4	26.6	36
<b>OR 319</b>	-	26.34	5.34	7	27	36.4	27.6	37
<b>OR 320</b>	-	27.97	5.34	7	28	37.4	29.6	39
<b>OR 321</b>	-	29.52	5.34	7	30	39.4	31.6	41
<b>OR 322</b>	-	31.12	5.34	7	31	40.4	32.6	42
<b>OR 323</b>	-	32.69	5.34	7	33	42.4	34.6	44
<b>OR 324</b>	-	34.29	5.34	7	35	44.4	35.6	45
<b>OR 325</b>	6150	37.47	5.34	7	38	47.4	38.6	48
<b>OR 326</b>	6162	40.65	5.34	7	41	50.4	42.6	52
<b>OR 327</b>	6175	43.82	5.34	7	44	53.4	45.6	55
<b>OR 328</b>	6187	47.00	5.34	7	47	56.4	48.6	58
<b>OR 329</b>	6200	50.16	5.34	7	50	59.4	51.6	61
<b>OR 330</b>	6212	53.34	5.34	7	53	62.4	54.6	64
<b>OR 331</b>	6225	56.52	5.34	7	57	66.4	58.6	68
<b>OR 332</b>	6237	59.69	5.34	7	60	69.4	60.6	70
<b>OR 333</b>	6250	62.87	5.34	7	63	72.4	63.6	73
<b>OR 334</b>	6262	66.04	5.34	7	66	75.4	67.6	77
<b>OR 335</b>	6275	69.22	5.34	7	69	78.4	70.6	80
<b>OR 336</b>	6287	72.39	5.34	7	73	82.4	73.6	83
<b>OR 619</b>	178	74.63	5.34	7	75	84.4	75.6	85

\* according to AS 568 A regulation

# OR

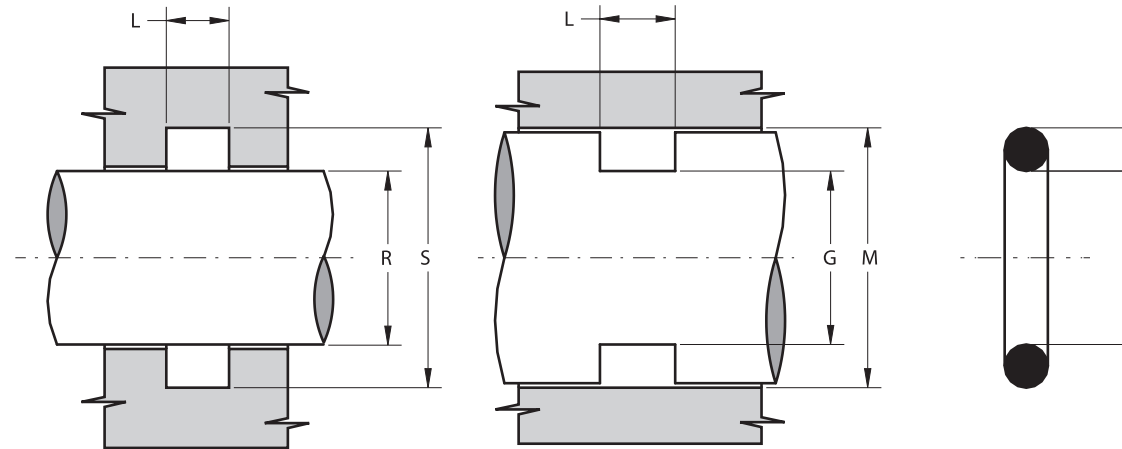

Cod. AS*	Cod. GB	d	c	L <sup>+0.2</sup>	R <sup>f7</sup>	S <sup>H9</sup>	G <sup>H9</sup>	M <sup>H8</sup>
OR 337	6300	75.57	5.34	7	76	85.4	76.6	86
OR 338	6312	78.74	5.34	7	79	88.4	80.6	90
OR 620	181	79.77	5.34	7	80	89.4	81.6	91
OR 339	6325	81.92	5.34	7	82	91.4	82.6	92
OR 340	6337	85.09	5.34	7	85	94.4	85.6	95
OR 341	6350	88.27	5.34	7	88	97.4	88.6	98
OR 621	185	89.69	5.34	7	90	99.4	90.6	100
OR 342	6362	91.44	5.34	7	92	101.4	92.6	102
OR 343	6375	94.62	5.34	7	95	104.4	95.6	105
OR 344	6387	97.79	5.34	7	98	107.4	98.6	108
OR 622	189	100.00	5.34	7	100	109.4	100.6	110
OR 345	6400	100.97	5.34	7	101	110.4	101.6	111
OR 346	6412	104.14	5.34	7	104	113.4	105.6	115
OR 347	6425	107.32	5.34	7	107	116.4	108.6	118
OR 623	193	109.50	5.34	7	110	119.4	110.6	120
OR 348	6437	110.50	5.34	7	111	120.4	111.6	121
OR 349	6450	113.67	5.34	7	114	123.4	115.6	125
OR 350	-	116.84	5.34	7	117	126.4	118.6	128
OR 860	199	117.50	5.34	7	118	127.4	118.6	128
OR 351	-	120.02	5.34	7	121	130.4	122.6	132
OR 861	201	120.70	5.34	7	121	130.4	122.6	132
OR 352	-	123.20	5.34	7	124	133.4	123.6	133

Cod. AS*	Cod. GB	d	c	L <sup>+0.2</sup>	R <sup>f7</sup>	S <sup>H9</sup>	G <sup>H9</sup>	M <sup>H8</sup>
OR 862	203	123.80	5.34	7	124	133.4	125.6	135
OR 353	-	126.37	5.34	7	127	136.4	127.6	137
OR 863	206	127.00	5.34	7	127	136.4	127.6	137
OR 354	-	129.54	5.34	7	130	139.4	130.6	140
OR 864	208	130.20	5.34	7	130	139.4	130.6	140
OR 355	-	132.72	5.34	7	133	142.4	133.6	143
OR 865	210	133.40	5.34	7	134	143.4	135.6	145
OR 356	-	135.90	5.34	7	137	146.4	137.6	147
OR 866	213	136.50	5.34	7	137	146.4	137.6	147
OR 357	-	139.07	5.34	7	140	149.4	140.6	150
OR 867	215	139.70	5.34	7	140	149.4	140.6	150
OR 358	-	142.24	5.34	7	143	152.4	143.6	153
OR 868	217	142.90	5.34	7	143	152.4	143.6	153
OR 359	-	145.42	5.34	7	146	155.4	146.6	156
OR 869	219	146.10	5.34	7	146	155.4	146.6	156
OR 360	-	148.60	5.34	7	150	159.4	150.6	160
OR 870	221	149.20	5.34	7	150	159.4	150.6	160
OR 361	6600	151.77	5.34	7	152	161.4	153.6	163
OR 362	6625	158.12	5.34	7	158	167.4	159.6	169
OR 363	6645	164.47	5.34	7	165	174.4	165.6	175
OR 364	6670	170.82	5.34	7	171	180.4	172.6	182
OR 365	6700	177.17	5.34	7	178	187.4	178.6	188

\* according to AS 568 A regulation

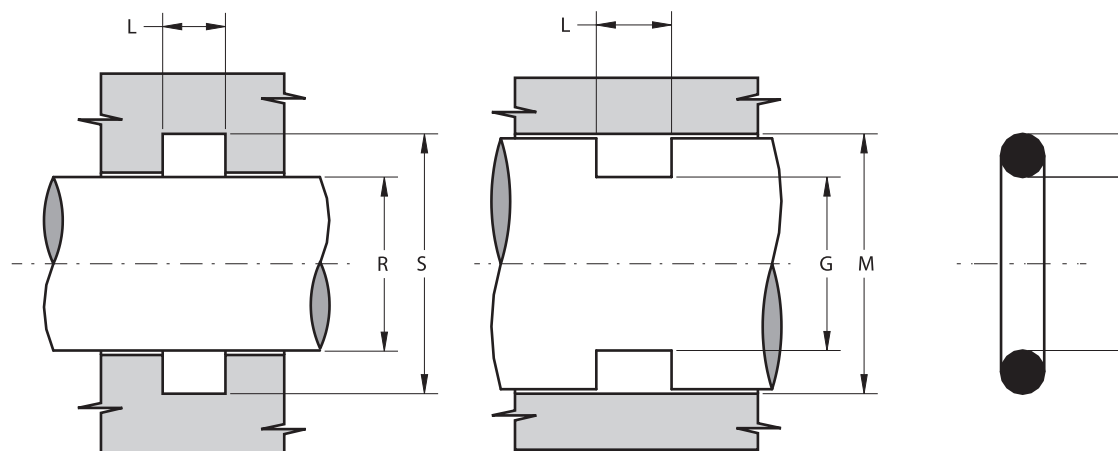

Cod. AS*	Cod. GB	d	c	L <sup>+0.2</sup>	R <sup>f7</sup>	S <sup>H9</sup>	G <sup>H9</sup>	M <sup>H8</sup>
<b>OR 366</b>	6720	183.52	5.34	7	184	193.4	185.6	195
<b>OR 367</b>	6745	189.87	5.34	7	190	199.4	190.6	200
<b>OR 368</b>	6775	196.22	5.34	7	196	205.4	197.6	207
<b>OR 369</b>	6795	202.57	5.34	7	202	211.4	203.6	213
<b>OR 370</b>	6820	208.92	5.34	7	209	218.4	210.6	220
<b>OR 371</b>	6850	215.27	5.34	7	215	224.4	216.6	226
<b>OR 372</b>	6870	221.62	5.34	7	222	231.4	222.6	232
<b>OR 373</b>	6895	227.97	5.34	7	228	237.4	229.6	239
<b>OR 374</b>	6920	234.32	5.34	7	234	243.4	235.6	245
<b>OR 375</b>	6945	240.67	5.34	7	241	250.4	242.6	252
<b>OR 376</b>	6975	247.02	5.34	7	247	256.4	248.6	258
<b>OR 377</b>	6995	253.37	5.34	7	253	262.4	255.6	265
<b>OR 378</b>	61050	266.07	5.34	7	266	275.4	267.6	277
<b>OR 379</b>	61100	278.77	5.34	7	280	289.4	280.6	290
<b>OR 380</b>	61150	291.47	5.34	7	292	301.4	293.6	303
<b>OR 381</b>	61200	304.17	5.34	7	304	313.4	305.6	315
<b>OR 382</b>	61300	329.57	5.34	7	330	339.4	330.6	340
<b>OR 383</b>	61400	354.97	5.34	7	355	364.4	355.6	365
<b>OR 384</b>	61500	380.37	5.34	7	380	389.4	382.6	392
<b>OR 385</b>	61600	405.26	5.34	7	405	414.4	406.6	416
<b>OR 386</b>	61700	430.66	5.34	7	431	440.4	432.6	442
<b>OR 387</b>	61800	456.06	5.34	7	456	465.4	458.6	468

Cod. AS*	Cod. GB	d	c	L <sup>+0.2</sup>	R <sup>f7</sup>	S <sup>H9</sup>	G <sup>H9</sup>	M <sup>H8</sup>
<b>OR 388</b>	61900	481.40	5.34	7	482	491.4	484.6	494
<b>OR 389</b>	62000	506.80	5.34	7	507	516.4	509.6	519
<b>OR 390</b>	62100	532.20	5.34	7	532	541.4	534.6	544
<b>OR 391</b>	-	557.60	5.34	7	558	567.4	560.6	570
<b>OR 392</b>	-	582.68	5.34	7	585	594.4	585.6	595
<b>OR 393</b>	-	608.08	5.34	7	610	619.4	610.6	620
<b>OR 394</b>	-	633.48	5.34	7	635	644.4	635.6	645
<b>OR 395</b>	-	658.88	5.34	7	660	669.4	660.6	670
<b>OR 425</b>	8450	113.67	6.99	9.5	114	126.2	114.8	127
<b>OR 624</b>	197	114.70	6.99	9.5	115	127.2	115.8	128
<b>OR 426</b>	8462	116.84	6.99	9.5	117	129.2	117.8	130
<b>OR 427</b>	8475	120.02	6.99	9.5	120	132.2	122.8	135
<b>OR 428</b>	8487	123.20	6.99	9.5	123	135.2	124.8	137
<b>OR 625</b>	204	124.60	6.99	9.5	125	137.2	125.8	138
<b>OR 429</b>	8500	126.37	6.99	9.5	126	138.2	127.8	140
<b>OR 430</b>	8512	129.54	6.99	9.5	130	142.2	130.8	143
<b>OR 431</b>	8525	132.72	6.99	9.5	133	145.2	133.8	146
<b>OR 626</b>	211	134.50	6.99	9.5	135	147.2	135.8	148
<b>OR 432</b>	8537	135.90	6.99	9.5	136	148.2	137.8	150
<b>OR 433</b>	8550	139.07	6.99	9.5	139	151.2	140.8	153
<b>OR 434</b>	8562	142.24	6.99	9.5	142	154.2	143.8	156

\* according to AS 568 A regulation

# OR

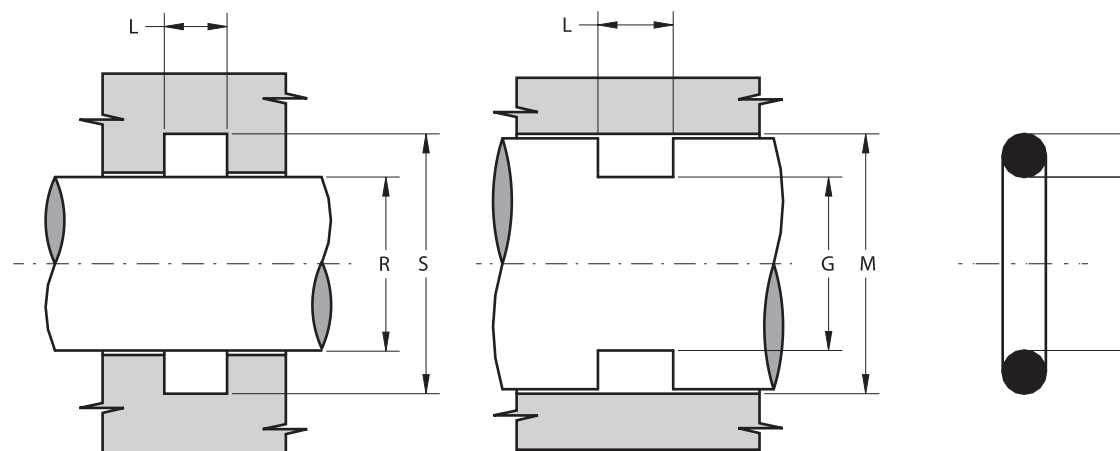

Cod. AS*	Cod. GB	d	c	L <sup>+0.2</sup>	R <sup>f7</sup>	S <sup>H9</sup>	G <sup>H9</sup>	M <sup>H8</sup>
OR 435	8575	145.42	6.99	9.5	145	157.2	147.8	160
OR 436	8587	148.60	6.99	9.5	149	161.2	149.8	162
OR 437	8600	151.77	6.99	9.5	152	164.2	152.8	165
OR 872	223	155.60	6.99	9.5	156	168.2	157.8	170
OR 438	8625	158.12	6.99	9.5	158	170.2	159.8	172
OR 627	225	159.50	6.99	9.5	160	172.2	160.8	173
OR 874	226	161.90	6.99	9.5	162	174.2	162.8	175
OR 439	8650	164.47	6.99	9.5	165	177.2	165.8	178
OR 628	228	166.70	6.99	9.5	167	179.2	167.8	180
OR 876	229	168.30	6.99	9.5	168	180.2	169.8	182
OR 440	8675	170.82	6.99	9.5	170	182.2	171.8	184
OR 878	231	174.60	6.99	9.5	175	187.2	175.8	188
OR 441	8700	177.17	6.99	9.5	178	190.2	178.8	191
OR 880	233	181.00	6.99	9.5	180	192.2	182.8	195
OR 442	8725	183.52	6.99	9.5	184	196.2	184.8	197
OR 882	235	187.30	6.99	9.5	188	200.2	187.8	200
OR 443	8750	189.87	6.99	9.5	190	202.2	190.8	203
OR 884	237	193.70	6.99	9.5	194	206.2	194.8	207
OR 444	8775	196.22	6.99	9.5	196	208.2	197.8	210
OR 886	239	200.00	6.99	9.5	200	212.2	201.8	214
OR 445	8800	202.57	6.99	9.5	203	215.2	203.8	216
OR 674	8825	208.92	6.99	9.5	210	222.2	209.8	222

Cod. AS*	Cod. GB	d	c	L <sup>+0.2</sup>	R <sup>f7</sup>	S <sup>H9</sup>	G <sup>H9</sup>	M <sup>H8</sup>
OR 446	8850	215.27	6.99	9.5	215	227.2	217.8	230
OR 676	8875	221.62	6.99	9.5	222	234.2	222.8	235
OR 447	8900	227.97	6.99	9.5	230	242.2	229.8	242
OR 678	8925	234.32	6.99	9.5	235	247.2	237.8	250
OR 448	8950	240.67	6.99	9.5	240	252.2	242.8	255
OR 680	8975	247.00	6.99	9.5	248	260.2	247.8	260
OR 449	81000	253.30	6.99	9.5	255	267.2	257.8	270
OR 682	81025	259.70	6.99	9.5	260	272.2	262.8	275
OR 450	81050	266.07	6.99	9.5	265	277.2	267.8	280
OR 684	81075	272.40	6.99	9.5	273	285.2	273.8	286
OR 451	81100	278.77	6.99	9.5	280	292.2	282.8	295
OR 686	81125	285.10	6.99	9.5	285	297.2	287.8	300
OR 452	81150	291.47	6.99	9.5	292	304.2	292.8	305
OR 688	81175	297.80	6.99	9.5	300	312.2	302.8	315
OR 453	81200	304.17	6.99	9.5	305	317.2	307.8	320
OR 454	81250	316.87	6.99	9.5	318	330.2	317.8	330
OR 455	81300	329.57	6.99	9.5	330	342.2	332.8	345
OR 456	81350	342.27	6.99	9.5	342	354.2	342.8	355
OR 457	81400	354.97	6.99	9.5	355	367.2	357.8	370
OR 458	81450	367.67	6.99	9.5	370	382.2	367.8	380
OR 459	81500	380.37	6.99	9.5	380	392.2	382.8	395
OR 460	81550	393.07	6.99	9.5	393	405.2	397.8	410

\* according to AS 568 A regulation

OR

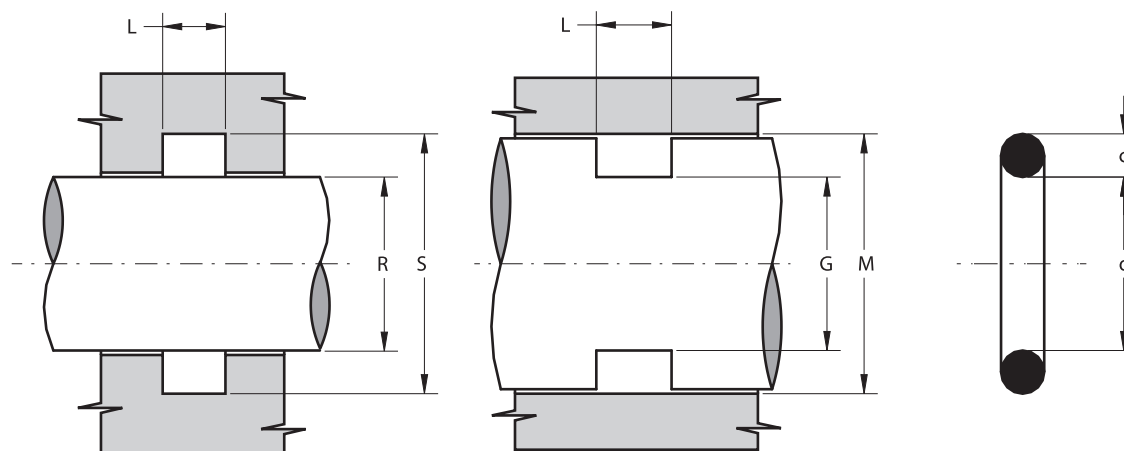

Cod. AS*	Cod. GB	d	c	L <sup>+0.2</sup>	R <sup>f7</sup>	S <sup>H9</sup>	G <sup>h9</sup>	M <sup>H8</sup>
<b>OR 461</b>	81600	405.26	6.99	9.5	405	417.2	407.8	420
<b>OR 462</b>	81650	417.96	6.99	9.5	418	430.2	419.8	432
<b>OR 463</b>	81700	430.66	6.99	9.5	431	443.2	432.8	445
<b>OR 464</b>	81750	443.36	6.99	9.5	445	457.2	447.8	460
<b>OR 465</b>	81800	456.06	6.99	9.5	458	470.2	457.8	470
<b>OR 466</b>	81850	468.76	6.99	9.5	470	482.2	467.8	480
<b>OR 467</b>	81900	481.46	6.99	9.5	483	495.2	482.8	495
<b>OR 468</b>	81950	494.16	6.99	9.5	495	507.2	497.8	510
<b>OR 469</b>	82000	506.86	6.99	9.5	508	520.2	507.8	520
<b>OR 470</b>	82100	532.26	6.99	9.5	535	547.2	532.8	545
<b>OR 471</b>	82200	557.66	6.99	9.5	560	572.2	557.8	570
<b>OR 472</b>	82300	582.68	6.99	9.5	580	592.2	587.8	600

\* according to AS 568 A regulation

# OR

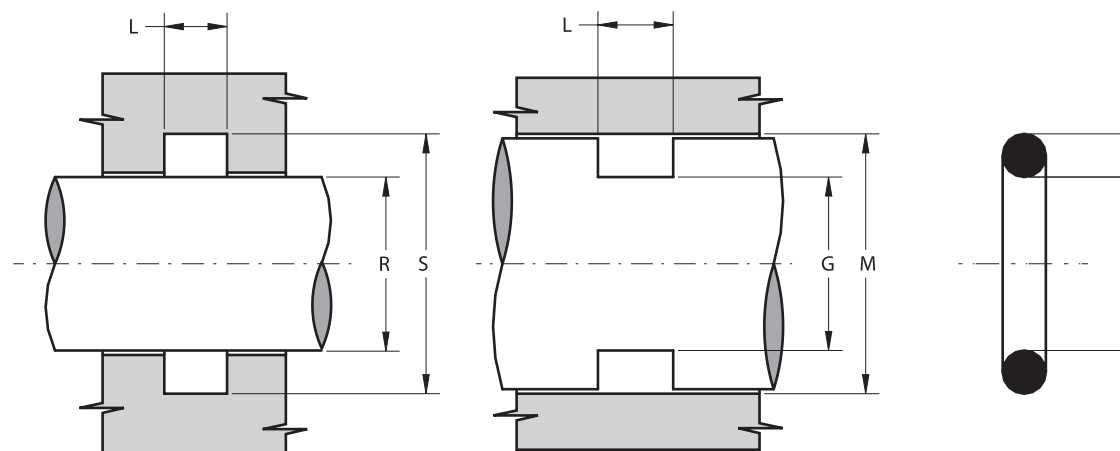

Cod. AS	d	c	L <sup>+0.2</sup>	R <sup>f7</sup>	S <sup>H9</sup>	G <sup>h9</sup>	M <sup>H8</sup>
Metric O-Ring							
OR 1,15X1	1.15	1	1.4	1	2.4	1.8	3.2
OR 1,5X1	1.5	1	1.4	1.5	2.9	2.1	3.5
OR 1,8X1	1.8	1	1.4	1.8	3.2	2.4	3.8
OR 2X1	2	1	1.4	2	3.4	2.6	4
OR 2,5X1	2.5	1	1.4	2.5	3.9	3.1	4.5
OR 3X1	3	1	1.4	3	4.4	3.6	5
OR 3,5X1	3.5	1	1.4	3.5	4.9	4.1	5.5
OR 4X1	4	1	1.4	4	5.4	4.6	6
OR 4,5X1	4.5	1	1.4	4.5	5.9	5.1	6.5
OR 5X1	5	1	1.4	5	6.4	5.6	7
OR 5,5X1	5.5	1	1.4	5.5	6.9	6.1	7.5
OR 6X1	6	1	1.4	6	7.4	6.6	8
OR 6,5X1	6.5	1	1.4	6.5	7.9	7.1	8.5
OR 7X1	7	1	1.4	7	8.4	7.6	9
OR 7,5X1	7.5	1	1.4	7.5	8.9	8.1	9.5
OR 8X1	8	1	1.4	8	9.4	8.6	10
OR 8,5X1	8.5	1	1.4	8.5	9.9	9.1	10.5
OR 9X1	9	1	1.4	9	10.4	9.6	11
OR 9,5X1	9.5	1	1.4	9.5	10.9	10.1	11.5
OR 10X1	10	1	1.4	10	11.4	10.6	12
OR 10,5X1	10.5	1	1.4	10	11.4	11.1	12.5
OR 11X1	11	1	1.4	11	12.4	11.6	13

Cod. AS	d	c	L <sup>+0.2</sup>	R <sup>f7</sup>	S <sup>H9</sup>	G <sup>h9</sup>	M <sup>H8</sup>
OR 11,5X1	11.5	1	1.4	11	12.4	12.6	14
OR 12X1	12	1	1.4	12	13.4	12.6	14
OR 12,5X1	12.5	1	1.4	12	13.4	13.6	15
OR 13X1	13	1	1.4	13	14.4	13.6	15
OR 13,5X1	13.5	1	1.4	13	14.4	14.6	16
OR 14X1	14	1	1.4	14	15.4	14.6	16
OR 14,5X1	14.5	1	1.4	14	15.4	15.6	17
OR 15,5X1	15.5	1	1.4	15	16.4	16.6	18
OR 16X1	16	1	1.4	16	17.4	16.6	18
OR 16,5X1	16.5	1	1.4	16	17.4	17.6	19
OR 17X1	17	1	1.4	17	18.4	17.6	19
OR 17,5X1	17.5	1	1.4	17	18.4	18.6	20
OR 18X1	18	1	1.4	18	19.4	18.6	20
OR 18,5X1	18.5	1	1.4	18	19.4	19.6	21
OR 19X1	19	1	1.4	19	20.4	19.6	21
OR 19,5X1	19.5	1	1.4	19	20.4	20.6	22
OR 20X1	20	1	1.4	20	21.4	20.6	22
OR 20,5X1	20.5	1	1.4	20	21.4	21.6	23
OR 21X1	21	1	1.4	21	22.4	21.6	23
OR 21,5X1	21.5	1	1.4	21	22.4	22.6	24
OR 22X1	22	1	1.4	22	23.4	22.6	24
OR 22,5X1	22.5	1	1.4	22	23.4	23.6	25
OR 23X1	23	1	1.4	23	24.4	23.6	25
OR 23,5X1	23.5	1	1.4	23	24.4	24.6	26

Cod. AS	d	c	L <sup>+0.2</sup>	R <sup>f7</sup>	S <sup>H9</sup>	G <sup>h9</sup>	M <sup>H8</sup>
OR 24X1	24	1	1.4	24	25.4	24.6	26
OR 24,5X1	24.5	1	1.4	24	25.4	25.6	27
OR 25X1	25	1	1.4	25	26.4	25.6	27
OR 26X1	26	1	1.4	26	27.4	26.6	28
OR 27X1	27	1	1.4	27	28.4	27.6	29
OR 28X1	28	1	1.4	28	29.4	28.6	30
OR 29X1	29	1	1.4	29	30.4	29.6	31
OR 30X1	30	1	1.4	30	31.4	30.6	32
OR 34,4X1	34.4	1	1.4	34	35.4	35.6	37
OR 35X1	35	1	1.4	35	36.4	35.6	37
OR 36X1	36	1	1.4	36	37.4	36.6	38
OR 36,5X1	36.5	1	1.4	36	37.4	37.6	39
OR 38X1	38	1	1.4	38	39.4	38.6	40
OR 38,5X1	38.5	1	1.4	38	39.4	39.6	41
OR 40X1	40	1	1.4	40	41.4	40.6	42
OR 45X1	45	1	1.4	45	46.4	45.6	47
OR 74X1	74	1	1.4	74	75.4	74.6	76
OR 90X1	90	1	1.4	90	91.4	90.6	92
OR 94X1	94	1	1.4	94	95.4	94.6	96
OR 137X1	137	1	1.4	137	138.4	137.6	139
OR 1,5X1,5	1.5	1.5	2	1.5	3.9	2.1	4.5
OR 1,85X1,5	1.85	1.5	2	1.9	4.3	2.5	4.9
OR 2X1,5	2	1.5	2	2	4.4	2.6	5

# OR

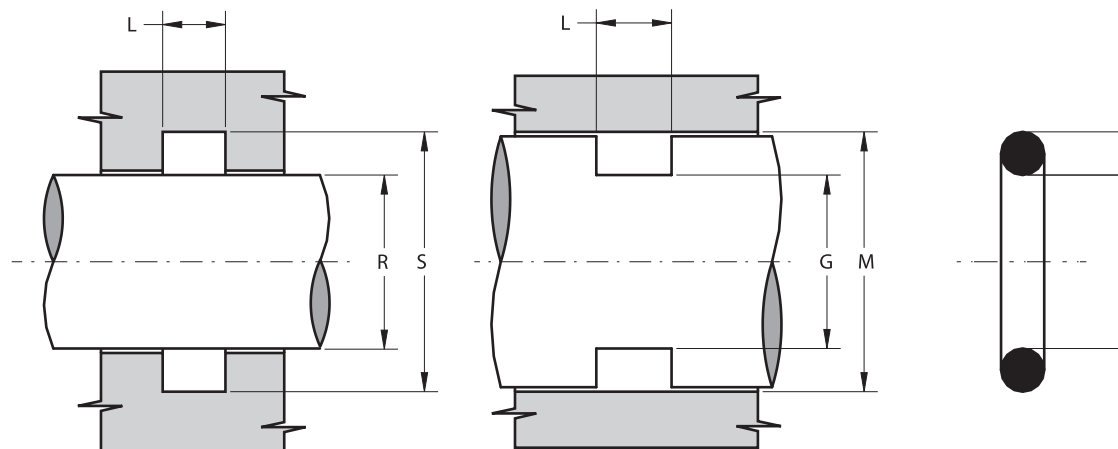

Cod. AS	d	c	L <sup>+0.2</sup>	R <sup>f7</sup>	S <sup>H9</sup>	G <sup>H9</sup>	M <sup>H8</sup>
OR 2,5X1,5	2.5	1.5	2	2.5	4.9	3.1	5.5
OR 2,8X1,5	2.8	1.5	2	2.8	5.2	3.4	5.8
OR 3X1,5	3	1.5	2	3	5.4	3.6	6
OR 3,5X1,5	3.5	1.5	2	3.5	5.9	4.1	6.5
OR 4X1,5	4	1.5	2	4	6.4	4.6	7
OR 4,5X1,5	4.5	1.5	2	4.5	6.9	5.1	7.5
OR 5X1,5	5	1.5	2	5	7.4	5.6	8
OR 5,5X1,5	5.5	1.5	2	5.5	7.9	6.1	8.5
OR 6,5X1,5	6.5	1.5	2	6.5	8.9	7.1	9.5
OR 7X1,5	7	1.5	2	7	9.4	7.6	10
OR 7,5X1,5	7.5	1.5	2	7.5	9.9	8.1	10.5
OR 8X1,5	8	1.5	2	8	10.4	8.6	11
OR 8,5X1,5	8.5	1.5	2	8.5	10.9	9.1	11.5
OR 9X1,5	9	1.5	2	9	11.4	9.6	12
OR 9,5X1,5	9.5	1.5	2	9.5	11.9	10.1	12.5
OR 10X1,5	10	1.5	2	10	12.4	10.6	13
OR 10,5X1,5	10.5	1.5	2	10	12.4	11.1	13.5
OR 11X1,5	11	1.5	2	11	13.4	11.6	14
OR 11,5X1,5	11.5	1.5	2	11	13.4	12.6	15
OR 12X1,5	12	1.5	2	12	14.4	12.6	15
OR 12,5X1,5	12.5	1.5	2	12	14.4	13.6	16
OR 13X1,5	13	1.5	2	13	15.4	13.6	16
OR 13,5X1,5	13.5	1.5	2	13	15.4	14.6	17
OR 14X1,5	14	1.5	2	14	16.4	14.6	17

Cod. AS	d	c	L <sup>+0.2</sup>	R <sup>f7</sup>	S <sup>H9</sup>	G <sup>H9</sup>	M <sup>H8</sup>
OR 14,5X1,5	14.5	1.5	2	14	16.4	15.6	18
OR 15X1,5	15	1.5	2	15	17.4	15.6	18
OR 15,5X1,5	15.5	1.5	2	15	17.4	16.6	19
OR 16X1,5	16	1.5	2	16	18.4	16.6	19
OR 16,5X1,5	16.5	1.5	2	16	18.4	17.6	20
OR 17X1,5	17	1.5	2	17	19.4	17.6	20
OR 17,5X1,5	17.5	1.5	2	17	19.4	18.6	21
OR 18X1,5	18	1.5	2	18	20.4	18.6	21
OR 18,5X1,5	18.5	1.5	2	18	20.4	19.6	22
OR 19X1,5	19	1.5	2	19	21.4	19.6	22
OR 19,5X1,5	19.5	1.5	2	19	21.4	20.6	23
OR 20X1,5	20	1.5	2	20	22.4	20.6	23
OR 20,5X1,5	20.5	1.5	2	20	22.4	21.6	24
OR 21X1,5	21	1.5	2	21	23.4	21.6	24
OR 21,5X1,5	21.5	1.5	2	21	23.4	22.6	25
OR 22X1,5	22	1.5	2	22	24.4	22.6	25
OR 22,5X1,5	22.5	1.5	2	22	24.4	23.6	26
OR 23X1,5	23	1.5	2	23	25.4	23.6	26
OR 23,5X1,5	23.5	1.5	2	23	25.4	24.6	27
OR 24X1,5	24	1.5	2	24	26.4	24.6	27
OR 24,5X1,5	24.5	1.5	2	24	26.4	25.6	28
OR 25X1,5	25	1.5	2	25	27.4	25.6	28
OR 25,5X1,5	25.5	1.5	2	25	27.4	26.6	29
OR 26X1,5	26	1.5	2	26	28.4	26.6	29

Cod. AS	d	c	L <sup>+0.2</sup>	R <sup>f7</sup>	S <sup>H9</sup>	G <sup>H9</sup>	M <sup>H8</sup>
OR 26,5X1,5	26.5	1.5	2	26	28.4	27.6	30
OR 27X1,5	27	1.5	2	27	29.4	27.6	30
OR 27,5X1,5	27.5	1.5	2	27	29.4	28.6	31
OR 28X1,5	28	1.5	2	28	30.4	28.6	31
OR 28,5X1,5	28.5	1.5	2	28	30.4	29.6	32
OR 29X1,5	29	1.5	2	29	31.4	29.6	32
OR 29,5X1,5	29.5	1.5	2	29	31.4	30.6	33
OR 30X1,5	30	1.5	2	30	32.4	30.6	33
OR 30,5X1,5	30.5	1.5	2	30	32.4	31.6	34
OR 31X1,5	31	1.5	2	31	33.4	31.6	34
OR 31,5X1,5	31.5	1.5	2	31	33.4	32.6	35
OR 32X1,5	32	1.5	2	32	34.4	32.6	35
OR 32,5X1,5	32.5	1.5	2	32	34.4	33.6	36
OR 33X1,5	33	1.5	2	33	35.4	33.6	36
OR 33,5X1,5	33.5	1.5	2	33	35.4	34.6	37
OR 34X1,5	34	1.5	2	34	36.4	34.6	37
OR 34,5X1,5	34.5	1.5	2	34	36.4	35.6	38
OR 35X1,5	35	1.5	2	35	37.4	35.6	38
OR 35,5X1,5	35.5	1.5	2	35	37.4	36.6	39
OR 36X1,5	36	1.5	2	36	38.4	36.6	39
OR 36,5X1,5	36.5	1.5	2	36	38.4	37.6	40
OR 37X1,5	37	1.5	2	37	39.4	37.6	40
OR 37,5X1,5	37.5	1.5	2	37	39.4	38.6	41
OR 38X1,5	38	1.5	2	38	40.4	38.6	41



# OR

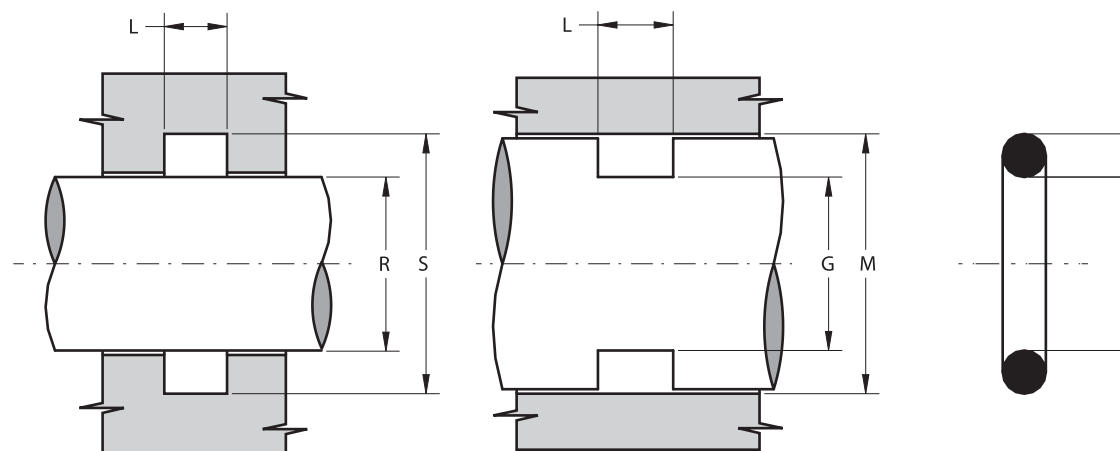

Cod. AS	d	c	L <sup>+0.2</sup>	R <sup>f7</sup>	S <sup>H9</sup>	G <sup>h9</sup>	M <sup>H8</sup>
OR 38,5X1,5	38.5	1.5	2	38	40.4	39.6	42
OR 39X1,5	39	1.5	2	39	41.4	39.6	42
OR 39,5X1,5	39.5	1.5	2	39	41.4	40.6	43
OR 40X1,5	40	1.5	2	40	42.4	40.6	43
OR 41X1,5	41	1.5	2	41	43.4	41.6	44
OR 42X1,5	42	1.5	2	42	44.4	42.6	45
OR 43X1,5	43	1.5	2	43	45.4	43.6	46
OR 44X1,5	44	1.5	2	44	46.4	44.6	47
OR 45X1,5	45	1.5	2	45	47.4	45.6	48
OR 46X1,5	46	1.5	2	46	48.4	46.6	49
OR 47X1,5	47	1.5	2	47	49.4	47.6	50
OR 48X1,5	48	1.5	2	48	50.4	48.6	51
OR 49X1,5	49	1.5	2	49	51.4	49.6	52
OR 50X1,5	50	1.5	2	50	52.4	50.6	53
OR 51X1,5	51	1.5	2	51	53.4	51.6	54
OR 52X1,5	52	1.5	2	52	54.4	52.6	55
OR 53X1,5	53	1.5	2	53	55.4	53.6	56
OR 54X1,5	54	1.5	2	54	56.4	54.6	57
OR 55X1,5	55	1.5	2	55	57.4	55.6	58
OR 56X1,5	56	1.5	2	56	58.4	56.6	59
OR 57X1,5	57	1.5	2	57	59.4	57.6	60
OR 58X1,5	58	1.5	2	58	60.4	58.6	61
OR 59X1,5	59	1.5	2	59	61.4	59.6	62
OR 60X1,5	60	1.5	2	60	62.4	60.6	63

Cod. AS	d	c	L <sup>+0.2</sup>	R <sup>f7</sup>	S <sup>H9</sup>	G <sup>h9</sup>	M <sup>H8</sup>
OR 61X1,5	61	1.5	2	61	63.4	61.6	64
OR 62X1,5	62	1.5	2	62	64.4	62.6	65
OR 63X1,5	63	1.5	2	63	65.4	63.6	66
OR 64X1,5	64	1.5	2	64	66.4	64.6	67
OR 65X1,5	65	1.5	2	65	67.4	65.6	68
OR 66X1,5	66	1.5	2	66	68.4	66.6	69
OR 67X1,5	67	1.5	2	67	69.4	67.6	70
OR 68X1,5	68	1.5	2	68	70.4	68.6	71
OR 69X1,5	69	1.5	2	69	71.4	69.6	72
OR 70X1,5	70	1.5	2	70	72.4	70.6	73
OR 71X1,5	71	1.5	2	71	73.4	71.6	74
OR 72X1,5	72	1.5	2	72	74.4	72.6	75
OR 73X1,5	73	1.5	2	73	75.4	73.6	76
OR 74X1,5	74	1.5	2	74	76.4	74.6	77
OR 75X1,5	75	1.5	2	75	77.4	75.6	78
OR 76X1,5	76	1.5	2	76	78.4	76.6	79
OR 77X1,5	77	1.5	2	77	79.4	77.6	80
OR 78X1,5	78	1.5	2	78	80.4	78.6	81
OR 79X1,5	79	1.5	2	79	81.4	79.6	82
OR 80X1,5	80	1.5	2	80	82.4	80.6	83
OR 81X1,5	81	1.5	2	81	83.4	81.6	84
OR 82X1,5	82	1.5	2	82	84.4	82.6	85
OR 83X1,5	83	1.5	2	83	85.4	83.6	86
OR 84X1,5	84	1.5	2	84	86.4	84.6	87

Cod. AS	d	c	L <sup>+0.2</sup>	R <sup>f7</sup>	S <sup>H9</sup>	G <sup>h9</sup>	M <sup>H8</sup>
OR 85X1,5	85	1.5	2	85	87.4	85.6	88
OR 87X1,5	87	1.5	2	87	89.4	87.6	90
OR 88X1,5	88	1.5	2	88	90.4	88.6	91
OR 89X1,5	89	1.5	2	89	91.4	89.6	92
OR 90X1,5	90	1.5	2	90	92.4	90.6	93
OR 91X1,5	91	1.5	2	91	93.4	91.6	94
OR 92X1,5	92	1.5	2	92	94.4	92.6	95
OR 93X1,5	93	1.5	2	93	95.4	93.6	96
OR 94X1,5	94	1.5	2	94	96.4	94.6	97
OR 95X1,5	95	1.5	2	95	97.4	95.6	98
OR 96X1,5	96	1.5	2	96	98.4	96.6	99
OR 97X1,5	97	1.5	2	97	99.4	97.6	100
OR 98X1,5	98	1.5	2	98	100.4	98.6	101
OR 99X1,5	99	1.5	2	99	101.4	99.6	102
OR 100X1,5	100	1.5	2	100	102.4	100.6	103
OR 105X1,5	105	1.5	2	105	107.4	105.6	108
OR 132X1,5	132	1.5	2	132	134.4	132.6	135
OR 2,7X1,6	2.7	1.6	2.1	2.7	5.2	3.4	5.9
OR 3,1X1,6	3.1	1.6	2.1	3.1	5.6	3.8	6.3
OR 4,1X1,6	4.1	1.6	2.1	4	6.5	5	7.5
OR 5,1X1,6	5.1	1.6	2.1	5	7.5	6	8.5
OR 5,2X1,6	5.2	1.6	2.1	5	7.5	6	8.5
OR 6,1X1,6	6.1	1.6	2.1	6	8.5	7	9.5

# OR

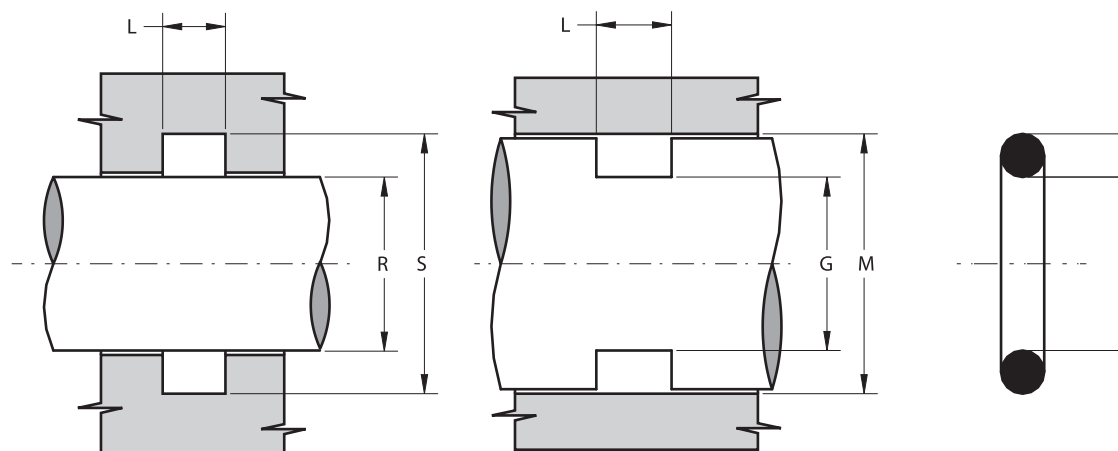

Cod. AS	d	c	L <sup>+0.2</sup>	R <sup>f7</sup>	S <sup>H9</sup>	G <sup>H9</sup>	M <sup>H8</sup>
<b>OR 7,1X1,6</b>	7.1	1.6	2.1	7	9.5	8	10.5
<b>OR 9,1X1,6</b>	9.1	1.6	2.1	9	11.5	10	12.5
<b>OR 9,5X1,6</b>	9.5	1.6	2.1	9.5	12	10.5	13
<b>OR 10,1X1,6</b>	10.1	1.6	2.1	10	12.5	11	13.5
<b>OR 11,1X1,6</b>	11.1	1.6	2.1	11	13.5	12.5	15
<b>OR 12,1X1,6</b>	12.1	1.6	2.1	12	14.5	13.5	16
<b>OR 13,1X1,6</b>	13.1	1.6	2.1	13	15.5	14.5	17
<b>OR 14,1X1,6</b>	14.1	1.6	2.1	14	16.5	15.5	18
<b>OR 15,1X1,6</b>	15.1	1.6	2.1	15	17.5	16.5	19
<b>OR 17,1X1,6</b>	17.1	1.6	2.1	17	19.5	18.5	21
<b>OR 18,1X1,6</b>	18.1	1.6	2.1	18	20.5	19.5	22
<b>OR 19,1X1,6</b>	19.1	1.6	2.1	19	21.5	20.5	23
<b>OR 22,1X1,6</b>	22.1	1.6	2.1	22	24.5	23.5	26
<b>OR 25,1X1,6</b>	25.1	1.6	2.1	25	27.5	26.5	29
<b>OR 27,1X1,6</b>	27.1	1.6	2.1	27	29.5	28.5	31
<b>OR 29,1X1,6</b>	29.1	1.6	2.1	29	31.5	30.5	33
<b>OR 32,1X1,6</b>	32.1	1.6	2.1	32	34.5	33.5	36
<b>OR 35,1X1,6</b>	35.1	1.6	2.1	35	37.5	36.5	39
<b>OR 37,1X1,6</b>	37.1	1.6	2.1	37	39.5	38.5	41
<b>OR 2,5X2</b>	2.5	2	2.7	2.5	5.8	3.2	6.5
<b>OR 3X2</b>	3	2	2.7	3	6.3	3.7	7
<b>OR 3,5X2</b>	3.5	2	2.7	3.5	6.8	4.2	7.5
<b>OR 4X2</b>	4	2	2.7	4	7.3	4.7	8

Cod. AS	d	c	L <sup>+0.2</sup>	R <sup>f7</sup>	S <sup>H9</sup>	G <sup>H9</sup>	M <sup>H8</sup>
<b>OR 4,5X2</b>	4.5	2	2.7	4.5	7.8	5.2	8.5
<b>OR 5X2</b>	5	2	2.7	5	8.3	5.7	9
<b>OR 5,5X2</b>	5.5	2	2.7	5.5	8.8	6.2	9.5
<b>OR 6X2</b>	6	2	2.7	6	9.3	6.7	10
<b>OR 6,5X2</b>	6.5	2	2.7	6.5	9.8	7.2	10.5
<b>OR 7X2</b>	7	2	2.7	7	10.3	7.7	11
<b>OR 7,5X2</b>	7.5	2	2.7	7.5	10.8	8.2	11.5
<b>OR 8X2</b>	8	2	2.7	8	11.3	8.7	12
<b>OR 8,5X2</b>	8.5	2	2.7	8.5	11.8	9.2	12.5
<b>OR 9X2</b>	9	2	2.7	9	12.3	9.7	13
<b>OR 9,5X2</b>	9.5	2	2.7	9.5	12.8	10.2	13.5
<b>OR 10X2</b>	10	2	2.7	10	13.3	10.7	14
<b>OR 10,5X2</b>	10.5	2	2.7	10	13.3	11.7	15
<b>OR 11X2</b>	11	2	2.7	11	14.3	11.7	15
<b>OR 11,5X2</b>	11.5	2	2.7	11	14.3	12.7	16
<b>OR 12X2</b>	12	2	2.7	12	15.3	12.7	16
<b>OR 12,5X2</b>	12.5	2	2.7	12	15.3	13.7	17
<b>OR 13X2</b>	13	2	2.7	13	16.3	13.7	17
<b>OR 13,5X2</b>	13.5	2	2.7	13	16.3	14.7	18
<b>OR 14X2</b>	14	2	2.7	14	17.3	14.7	18
<b>OR 14,5X2</b>	14.5	2	2.7	14	17.3	15.7	19
<b>OR 15X2</b>	15	2	2.7	15	18.3	15.7	19
<b>OR 15,5X2</b>	15.5	2	2.7	15	18.3	16.7	20
<b>OR 16X2</b>	16	2	2.7	16	19.3	16.7	20

Cod. AS	d	c	L <sup>+0.2</sup>	R <sup>f7</sup>	S <sup>H9</sup>	G <sup>H9</sup>	M <sup>H8</sup>
<b>OR 16,5X2</b>	16.5	2	2.7	16	19.3	17.7	21
<b>OR 17X2</b>	17	2	2.7	17	20.3	17.7	21
<b>OR 17,5X2</b>	17.5	2	2.7	17	20.3	18.7	22
<b>OR 18X2</b>	18	2	2.7	18	21.3	18.7	22
<b>OR 18,5X2</b>	18.5	2	2.7	18	21.3	19.7	23
<b>OR 19X2</b>	19	2	2.7	19	22.3	19.7	23
<b>OR 19,5X2</b>	19.5	2	2.7	19	22.3	20.7	24
<b>OR 20X2</b>	20	2	2.7	20	23.3	20.7	24
<b>OR 20,5X2</b>	20.5	2	2.7	20	23.3	21.7	25
<b>OR 21X2</b>	21	2	2.7	21	24.3	21.7	25
<b>OR 21,5X2</b>	21.5	2	2.7	21	24.3	22.7	26
<b>OR 22X2</b>	22	2	2.7	22	25.3	22.7	26
<b>OR 22,5X2</b>	22.5	2	2.7	22	25.3	23.7	27
<b>OR 23X2</b>	23	2	2.7	23	26.3	23.7	27
<b>OR 23,5X2</b>	23.5	2	2.7	23	26.3	24.7	28
<b>OR 24X2</b>	24	2	2.7	24	27.3	24.7	28
<b>OR 24,5X2</b>	24.5	2	2.7	24	27.3	25.7	29
<b>OR 25X2</b>	25	2	2.7	25	28.3	25.7	29
<b>OR 25,5X2</b>	25.5	2	2.7	25	28.3	26.7	30
<b>OR 26X2</b>	26	2	2.7	26	29.3	26.7	30
<b>OR 26,5X2</b>	26.5	2	2.7	26	29.3	27.7	31
<b>OR 27X2</b>	27	2	2.7	27	30.3	27.7	31
<b>OR 27,5X2</b>	27.5	2	2.7	27	30.3	28.7	32
<b>OR 28X2</b>	28	2	2.7	28	31.3	28.7	32

# OR

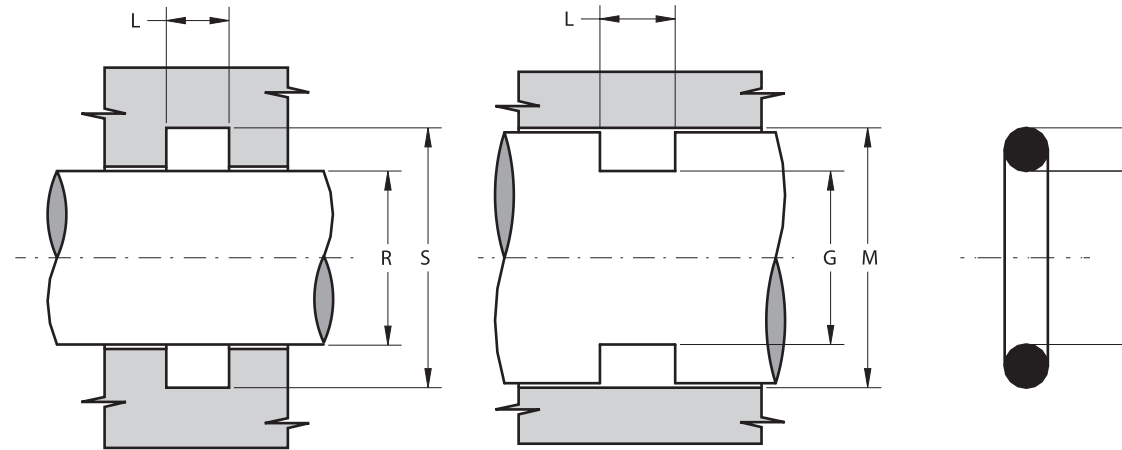

Cod. AS	d	c	L <sup>+0.2</sup>	R <sup>f7</sup>	S <sup>H9</sup>	G <sup>h9</sup>	M <sup>H8</sup>
OR 28,5X2	28.5	2	2.7	28	31.3	29.7	33
OR 29X2	29	2	2.7	29	32.3	29.7	33
OR 29,5X2	29.5	2	2.7	29	32.3	30.7	34
OR 30X2	30	2	2.7	30	33.3	30.7	34
OR 30,5X2	30.5	2	2.7	30	33.3	31.7	35
OR 31X2	31	2	2.7	31	34.3	31.7	35
OR 31,5X2	31.5	2	2.7	31	34.3	32.7	36
OR 32X2	32	2	2.7	32	35.3	32.7	36
OR 32,5X2	32.5	2	2.7	32	35.3	33.7	37
OR 33X2	33	2	2.7	33	36.3	33.7	37
OR 33,5X2	33.5	2	2.7	33	36.3	34.7	38
OR 34X2	34	2	2.7	34	37.3	34.7	38
OR 34,5X2	34.5	2	2.7	34	37.3	35.7	39
OR 35X2	35	2	2.7	35	38.3	35.7	39
OR 35,5X2	35.5	2	2.7	35	38.3	36.7	40
OR 36X2	36	2	2.7	36	39.3	36.7	40
OR 36,5X2	36.5	2	2.7	36	39.3	37.7	41
OR 37X2	37	2	2.7	37	40.3	37.7	41
OR 37,5X2	37.5	2	2.7	37	40.3	38.7	42
OR 38X2	38	2	2.7	38	41.3	38.7	42
OR 38,5X2	38.5	2	2.7	38	41.3	39.7	43
OR 39X2	39	2	2.7	39	42.3	39.7	43
OR 39,5X2	39.5	2	2.7	39	42.3	40.7	44
OR 40X2	40	2	2.7	40	43.3	40.7	44

Cod. AS	d	c	L <sup>+0.2</sup>	R <sup>f7</sup>	S <sup>H9</sup>	G <sup>h9</sup>	M <sup>H8</sup>
OR 41X2	41	2	2.7	41	44.3	41.7	45
OR 42X2	42	2	2.7	42	45.3	42.7	46
OR 43X2	43	2	2.7	43	46.3	43.7	47
OR 44X2	44	2	2.7	44	47.3	44.7	48
OR 44,5X2	44.5	2	2.7	44	47.3	45.7	49
OR 45X2	45	2	2.7	45	48.3	45.7	49
OR 46X2	46	2	2.7	46	49.3	46.7	50
OR 47X2	47	2	2.7	47	50.3	47.7	51
OR 48X2	48	2	2.7	48	51.3	48.7	52
OR 49X2	49	2	2.7	49	52.3	49.7	53
OR 50X2	50	2	2.7	50	53.3	50.7	54
OR 51X2	51	2	2.7	51	54.3	51.7	55
OR 52X2	52	2	2.7	52	55.3	52.7	56
OR 53X2	53	2	2.7	53	56.3	53.7	57
OR 54X2	54	2	2.7	54	57.3	54.7	58
OR 55X2	55	2	2.7	55	58.3	55.7	59
OR 56X2	56	2	2.7	56	59.3	56.7	60
OR 57X2	57	2	2.7	57	60.3	57.7	61
OR 58X2	58	2	2.7	58	61.3	58.7	62
OR 59X2	59	2	2.7	59	62.3	59.7	63
OR 60X2	60	2	2.7	60	63.3	60.7	64
OR 61X2	61	2	2.7	61	64.3	61.7	65
OR 62X2	62	2	2.7	62	65.3	62.7	66
OR 63X2	63	2	2.7	63	66.3	63.7	67

Cod. AS	d	c	L <sup>+0.2</sup>	R <sup>f7</sup>	S <sup>H9</sup>	G <sup>h9</sup>	M <sup>H8</sup>
OR 64X2	64	2	2.7	64	67.3	64.7	68
OR 65X2	65	2	2.7	65	68.3	65.7	69
OR 66X2	66	2	2.7	66	69.3	66.7	70
OR 67X2	67	2	2.7	67	70.3	67.7	71
OR 68X2	68	2	2.7	68	71.3	68.7	72
OR 69X2	69	2	2.7	69	72.3	69.7	73
OR 70X2	70	2	2.7	70	73.3	70.7	74
OR 71X2	71	2	2.7	71	74.3	71.7	75
OR 72X2	72	2	2.7	72	75.3	72.7	76
OR 73X2	73	2	2.7	73	76.3	73.7	77
OR 73,5X2	73.5	2	2.7	73	76.3	74.7	78
OR 74X2	74	2	2.7	74	77.3	74.7	78
OR 75X2	75	2	2.7	75	78.3	75.7	79
OR 76X2	76	2	2.7	76	79.3	76.7	80
OR 77X2	77	2	2.7	77	80.3	77.7	81
OR 78X2	78	2	2.7	78	81.3	78.7	82
OR 79X2	79	2	2.7	79	82.3	79.7	83
OR 80X2	80	2	2.7	80	83.3	80.7	84
OR 81X2	81	2	2.7	81	84.3	81.7	85
OR 82X2	82	2	2.7	82	85.3	82.7	86
OR 83X2	83	2	2.7	83	86.3	83.7	87
OR 84X2	84	2	2.7	84	87.3	84.7	88
OR 85X2	85	2	2.7	85	88.3	85.7	89
OR 86X2	86	2	2.7	86	89.3	86.7	90

# OR

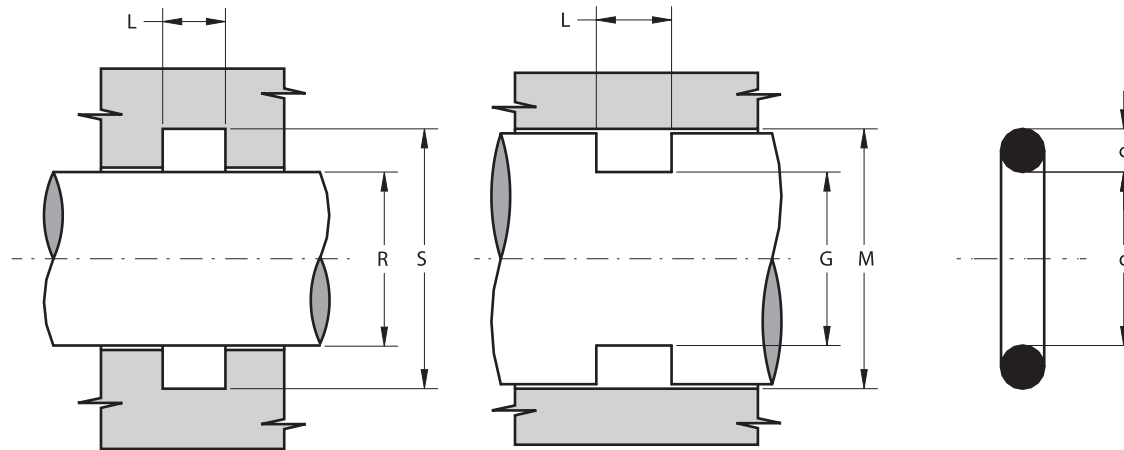

Cod. AS	d	c	L <sup>+0.2</sup>	R <sup>f7</sup>	S <sup>H9</sup>	G <sup>H9</sup>	M <sup>H8</sup>
OR 87X2	87	2	2.7	87	90.3	87.7	91
OR 88X2	88	2	2.7	88	91.3	88.7	92
OR 89X2	89	2	2.7	89	92.3	89.7	93
OR 90X2	90	2	2.7	90	93.3	90.7	94
OR 91X2	91	2	2.7	91	94.3	91.7	95
OR 92X2	92	2	2.7	92	95.3	92.7	96
OR 93X2	93	2	2.7	93	96.3	93.7	97
OR 94X2	94	2	2.7	94	97.3	94.7	98
OR 95X2	95	2	2.7	95	98.3	95.7	99
OR 96X2	96	2	2.7	96	99.3	96.7	100
OR 97X2	97	2	2.7	97	100.3	97.7	101
OR 98X2	98	2	2.7	98	101.3	98.7	102
OR 99X2	99	2	2.7	99	102.3	99.7	103
OR 100X2	100	2	2.7	100	103.3	100.7	104
OR 104X2	104	2	2.7	104	107.3	104.7	108
OR 106X2	106	2	2.7	106	109.3	106.7	110
OR 110X2	110	2	2.7	110	113.3	110.7	114
OR 112X2	112	2	2.7	112	115.3	112.7	116
OR 118,5X2	118.5	2	2.7	118	121.3	119.7	123
OR 120X2	120	2	2.7	120	123.3	120.7	124
OR 125X2	125	2	2.7	125	128.3	125.7	129
OR 128X2	128	2	2.7	128	131.3	128.7	132
OR 132X2	132	2	2.7	132	135.3	132.7	136
OR 143X2	143	2	2.7	143	146.3	143.7	147

Cod. AS	d	c	L <sup>+0.2</sup>	R <sup>f7</sup>	S <sup>H9</sup>	G <sup>H9</sup>	M <sup>H8</sup>
OR 143,5X2	143.5	2	2.7	143	146.3	144.7	148
OR 180X2	180	2	2.7	180	183.3	181.7	185
OR 195X2	195	2	2.7	195	198.3	196.7	200
OR 234X2	234	2	2.7	230	233.3	236.7	240
OR 3,3X2,4	3.3	2.4	3.2	3.3	7.3	4.1	8.1
OR 3,6X2,4	3.6	2.4	3.2	3.5	7.5	4.4	8.4
OR 4,3X2,4	4.3	2.4	3.2	4.3	8.3	5.5	9.5
OR 4,6X2,4	4.6	2.4	3.2	4.6	8.6	5.5	9.5
OR 5,3X2,4	5.3	2.4	3.2	5	9	6.5	10.5
OR 5,5X2,4	5.5	2.4	3.2	5.5	9.5	6.5	10.5
OR 5,6X2,4	5.6	2.4	3.2	5.5	9.5	6.5	10.5
OR 6,3X2,4	6.3	2.4	3.2	6	10	7.5	11.5
OR 6,6X2,4	6.6	2.4	3.2	6.5	10.5	7.5	11.5
OR 7,3X2,4	7.3	2.4	3.2	7	11	8.5	12.5
OR 7,5X2,4	7.5	2.4	3.2	7.5	11.5	8.5	12.5
OR 7,6X2,4	7.6	2.4	3.2	7.5	11.5	8.5	12.5
OR 8,3X2,4	8.3	2.4	3.2	8	12	9.5	13.5
OR 8,6X2,4	8.6	2.4	3.2	8.5	12.5	9.5	13.5
OR 9,3X2,4	9.3	2.4	3.2	9	13	10.5	14.5
OR 9,6X2,4	9.6	2.4	3.2	9.5	13.5	10.5	14.5
OR 10,3X2,4	10.3	2.4	3.2	10	14	11.5	15.5
OR 10,5X2,4	10.5	2.4	3.2	10	14	12	16
OR 10,6X2,4	10.6	2.4	3.2	10	14	12	16

Cod. AS	d	c	L <sup>+0.2</sup>	R <sup>f7</sup>	S <sup>H9</sup>	G <sup>H9</sup>	M <sup>H8</sup>
OR 11,3X2,4	11.3	2.4	3.2	11	15	13	17
OR 11,5X2,4	11.5	2.4	3.2	11	15	13	17
OR 11,6X2,4	11.6	2.4	3.2	11	15	13	17
OR 12,3X2,4	12.3	2.4	3.2	12	16	14	18
OR 12,6X2,4	12.6	2.4	3.2	12	16	14	18
OR 13,3X2,4	13.3	2.4	3.2	13	17	15	19
OR 13,5X2,4	13.5	2.4	3.2	13	17	15	19
OR 13,6X2,4	13.6	2.4	3.2	13	17	15	19
OR 14,3X2,4	14.3	2.4	3.2	14	18	16	20
OR 14,5X2,4	14.5	2.4	3.2	14	18	16	20
OR 14,6X2,4	14.6	2.4	3.2	14	18	16	20
OR 15,3X2,4	15.3	2.4	3.2	15	19	17	21
OR 15,5X2,4	15.5	2.4	3.2	15	19	17	21
OR 15,6X2,4	15.6	2.4	3.2	15	19	17	21
OR 16,3X2,4	16.3	2.4	3.2	16	20	18	22
OR 16,6X2,4	16.6	2.4	3.2	16	20	18	22
OR 17,3X2,4	17.3	2.4	3.2	17	21	19	23
OR 17,5X2,4	17.5	2.4	3.2	17	21	19	23
OR 17,6X2,4	17.6	2.4	3.2	17	21	19	23
OR 18,6X2,4	18.6	2.4	3.2	18	22	20	24
OR 19,3X2,4	19.3	2.4	3.2	19	23	21	25
OR 19,6X2,4	19.6	2.4	3.2	19	23	21	25
OR 20,3X2,4	20.3	2.4	3.2	20	24	22	26
OR 20,5X2,4	20.5	2.4	3.2	20	24	22	26

# OR

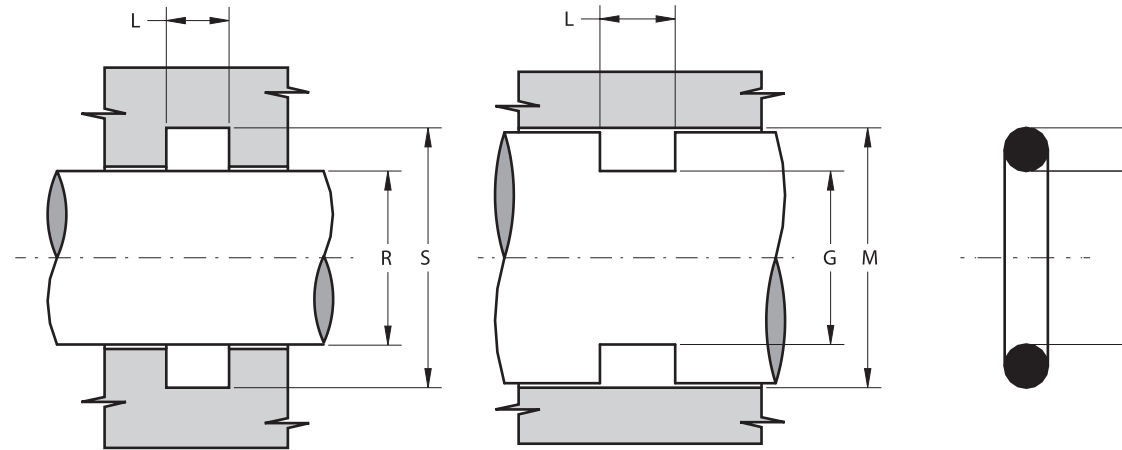

Cod. AS	d	c	L <sup>+0.2</sup>	R <sup>f7</sup>	S <sup>H9</sup>	G <sup>h9</sup>	M <sup>H8</sup>
OR 21,3X2,4	21.3	2.4	3.2	21	25	23	27
OR 21,5X2,4	21.5	2.4	3.2	21	25	23	27
OR 21,6X2,4	21.6	2.4	3.2	21	25	23	27
OR 22,3X2,4	22.3	2.4	3.2	22	26	24	28
OR 23,5X2,4	23.5	2.4	3.2	23	27	25	29
OR 24,5X2,4	24.5	2.4	3.2	24	28	26	30
OR 24,6X2,4	24.6	2.4	3.2	24	28	26	30
OR 25X2,4	25	2.4	3.2	25	29	26	30
OR 25,3X2,4	25.3	2.4	3.2	25	29	27	31
OR 27,3X2,4	27.3	2.4	3.2	27	31	29	33
OR 27,5X2,4	27.5	2.4	3.2	27	31	29	33
OR 27,6X2,4	27.6	2.4	3.2	27	31	29	33
OR 29,6X2,4	29.6	2.4	3.2	29	33	31	35
OR 31,6X2,4	31.6	2.4	3.2	31	35	33	37
OR 33X2,4	33	2.4	3.2	33	37	34	38
OR 33,3X2,4	33.3	2.4	3.2	33	37	35	39
OR 34,6X2,4	34.6	2.4	3.2	34	38	36	40
OR 37,6X2,4	37.6	2.4	3.2	37	41	39	43
OR 39,6X2,4	39.6	2.4	3.2	39	43	41	45
OR 41,6X2,4	41.6	2.4	3.2	41	45	43	47
OR 44,6X2,4	44.6	2.4	3.2	44	48	46	50
OR 49,6X2,4	49.6	2.4	3.2	49	53	51	55
OR 51,6X2,4	51.6	2.4	3.2	51	55	53	57
OR 54,6X2,4	54.6	2.4	3.2	54	58	56	60

Cod. AS	d	c	L <sup>+0.2</sup>	R <sup>f7</sup>	S <sup>H9</sup>	G <sup>h9</sup>	M <sup>H8</sup>
OR 57,6X2,4	57.6	2.4	3.2	57	61	59	63
OR 59,6X2,4	59.6	2.4	3.2	59	63	61	65
OR 61,6X2,4	61.6	2.4	3.2	61	65	63	67
OR 64,6X2,4	64.6	2.4	3.2	64	68	66	70
OR 67,6X2,4	67.6	2.4	3.2	67	71	69	73
OR 69,6X2,4	69.6	2.4	3.2	69	73	71	75
OR 4X2,5	4	2.5	3.3	4	8.2	4.8	9
OR 5X2,5	5	2.5	3.3	5	9.2	5.8	10
OR 5,5X2,5	5.5	2.5	3.3	5.5	9.7	6.3	10.5
OR 6X2,5	6	2.5	3.3	6	10.2	6.8	11
OR 6,5X2,5	6.5	2.5	3.3	6.5	10.7	7.3	11.5
OR 7X2,5	7	2.5	3.3	7	11.2	7.8	12
OR 7,5X2,5	7.5	2.5	3.3	7.5	11.7	8.3	12.5
OR 8X2,5	8	2.5	3.3	8	12.2	8.8	13
OR 8,5X2,5	8.5	2.5	3.3	8.5	12.7	9.3	13.5
OR 9X2,5	9	2.5	3.3	9	13.2	9.8	14
OR 9,5X2,5	9.5	2.5	3.3	9.5	13.7	10.3	14.5
OR 10X2,5	10	2.5	3.3	10	14.2	10.8	15
OR 10,5X2,5	10.5	2.5	3.3	10	14.2	11.8	16
OR 11X2,5	11	2.5	3.3	11	15.2	11.8	16
OR 11,5X2,5	11.5	2.5	3.3	11	15.2	12.8	17
OR 12X2,5	12	2.5	3.3	12	16.2	12.8	17
OR 13X2,5	13	2.5	3.3	13	17.2	13.8	18

Cod. AS	d	c	L <sup>+0.2</sup>	R <sup>f7</sup>	S <sup>H9</sup>	G <sup>h9</sup>	M <sup>H8</sup>
OR 13,5X2,5	13.5	2.5	3.3	13	17.2	14.8	19
OR 14X2,5	14	2.5	3.3	14	18.2	14.8	19
OR 14,5X2,5	14.5	2.5	3.3	14	18.2	15.8	20
OR 15X2,5	15	2.5	3.3	15	19.2	15.8	20
OR 15,5X2,5	15.5	2.5	3.3	15	19.2	16.8	21
OR 16X2,5	16	2.5	3.3	16	20.2	16.8	21
OR 17X2,5	17	2.5	3.3	17	21.2	17.8	22
OR 17,5X2,5	17.5	2.5	3.3	17	21.2	18.8	23
OR 18X2,5	18	2.5	3.3	18	22.2	18.8	23
OR 19X2,5	19	2.5	3.3	19	23.2	19.8	24
OR 19,5X2,5	19.5	2.5	3.3	19	23.2	20.8	25
OR 20X2,5	20	2.5	3.3	20	24.2	20.8	25
OR 20,5X2,5	20.5	2.5	3.3	20	24.2	21.8	26
OR 21X2,5	21	2.5	3.3	21	25.2	21.8	26
OR 21,5X2,5	21.5	2.5	3.3	21	25.2	22.8	27
OR 22X2,5	22	2.5	3.3	22	26.2	22.8	27
OR 22,5X2,5	22.5	2.5	3.3	22	26.2	23.8	28
OR 23X2,5	23	2.5	3.3	23	27.2	23.8	28
OR 24X2,5	24	2.5	3.3	24	28.2	24.8	29
OR 24,5X2,5	24.5	2.5	3.3	24	28.2	25.8	30
OR 25X2,5	25	2.5	3.3	25	29.2	25.8	30
OR 26X2,5	26	2.5	3.3	26	30.2	26.8	31
OR 27X2,5	27	2.5	3.3	27	31.2	27.8	32
OR 28X2,5	28	2.5	3.3	28	32.2	28.8	33

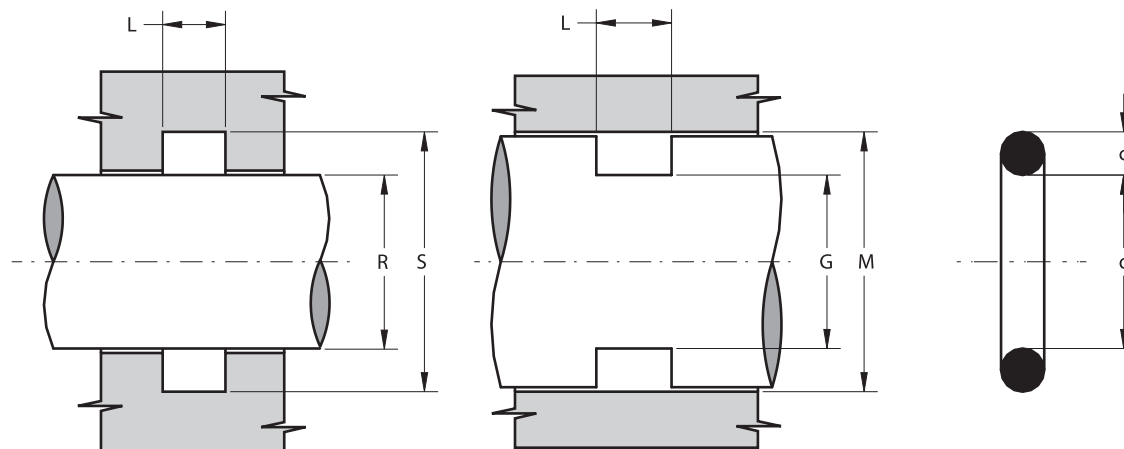

Cod. AS	d	c	L <sup>+0.2</sup>	R <sup>f7</sup>	S <sup>H9</sup>	G <sup>H9</sup>	M <sup>H8</sup>
OR 29X2,5	29	2.5	3.3	29	33.2	29.8	34
OR 29,5X2,5	29.5	2.5	3.3	29	33.2	30.8	35
OR 30X2,5	30	2.5	3.3	30	34.2	30.8	35
OR 30,5X2,5	30.5	2.5	3.3	30	34.2	31.8	36
OR 31X2,5	31	2.5	3.3	31	35.2	31.8	36
OR 32X2,5	32	2.5	3.3	32	36.2	32.8	37
OR 32,5X2,5	32.5	2.5	3.3	32	36.2	33.8	38
OR 33X2,5	33	2.5	3.3	33	37.2	33.8	38
OR 33,5X2,5	33.5	2.5	3.3	33	37.2	34.8	39
OR 34X2,5	34	2.5	3.3	34	38.2	34.8	39
OR 35X2,5	35	2.5	3.3	35	39.2	35.8	40
OR 35,5X2,5	35.5	2.5	3.3	35	39.2	36.8	41
OR 36X2,5	36	2.5	3.3	36	40.2	36.8	41
OR 37X2,5	37	2.5	3.3	37	41.2	37.8	42
OR 38X2,5	38	2.5	3.3	38	42.2	38.8	43
OR 39X2,5	39	2.5	3.3	39	43.2	39.8	44
OR 40X2,5	40	2.5	3.3	40	44.2	40.8	45
OR 41X2,5	41	2.5	3.3	41	45.2	41.8	46
OR 42X2,5	42	2.5	3.3	42	46.2	42.8	47
OR 43X2,5	43	2.5	3.3	43	47.2	43.8	48
OR 44X2,5	44	2.5	3.3	44	48.2	44.8	49
OR 45X2,5	45	2.5	3.3	45	49.2	45.8	50
OR 46X2,5	46	2.5	3.3	46	50.2	46.8	51
OR 47X2,5	47	2.5	3.3	47	51.2	47.8	52

Cod. AS	d	c	L <sup>+0.2</sup>	R <sup>f7</sup>	S <sup>H9</sup>	G <sup>H9</sup>	M <sup>H8</sup>
OR 48X2,5	48	2.5	3.3	48	52.2	48.8	53
OR 49X2,5	49	2.5	3.3	49	53.2	49.8	54
OR 50X2,5	50	2.5	3.3	50	54.2	50.8	55
OR 50,5X2,5	50.5	2.5	3.3	50	54.2	51.8	56
OR 51X2,5	51	2.5	3.3	51	55.2	51.8	56
OR 52X2,5	52	2.5	3.3	52	56.2	52.8	57
OR 54X2,5	54	2.5	3.3	54	58.2	54.8	59
OR 55X2,5	55	2.5	3.3	55	59.2	55.8	60
OR 56X2,5	56	2.5	3.3	56	60.2	56.8	61
OR 57X2,5	57	2.5	3.3	57	61.2	57.8	62
OR 58X2,5	58	2.5	3.3	58	62.2	58.8	63
OR 60X2,5	60	2.5	3.3	60	64.2	60.8	65
OR 62X2,5	62	2.5	3.3	62	66.2	62.8	67
OR 62X2,5	62	2.5	3.3	62	66.2	62.8	67
OR 63X2,5	63	2.5	3.3	63	67.2	63.8	68
OR 64X2,5	64	2.5	3.3	64	68.2	64.8	69
OR 65X2,5	65	2.5	3.3	65	69.2	65.8	70
OR 66X2,5	66	2.5	3.3	66	70.2	66.8	71
OR 67X2,5	67	2.5	3.3	67	71.2	67.8	72
OR 68X2,5	68	2.5	3.3	68	72.2	68.8	73
OR 69X2,5	69	2.5	3.3	69	73.2	69.8	74
OR 70X2,5	70	2.5	3.3	70	74.2	70.8	75
OR 71X2,5	71	2.5	3.3	71	75.2	71.8	76
OR 72X2,5	72	2.5	3.3	72	76.2	72.8	77

Cod. AS	d	c	L <sup>+0.2</sup>	R <sup>f7</sup>	S <sup>H9</sup>	G <sup>H9</sup>	M <sup>H8</sup>
OR 73X2,5	73	2.5	3.3	73	77.2	73.8	78
OR 74X2,5	74	2.5	3.3	74	78.2	74.8	79
OR 75X2,5	75	2.5	3.3	75	79.2	75.8	80
OR 76X2,5	76	2.5	3.3	76	80.2	76.8	81
OR 78X2,5	78	2.5	3.3	78	82.2	78.8	83
OR 80X2,5	80	2.5	3.3	80	84.2	80.8	85
OR 85X2,5	85	2.5	3.3	85	89.2	85.8	90
OR 86X2,5	86	2.5	3.3	86	90.2	86.8	91
OR 87X2,5	87	2.5	3.3	87	91.2	87.8	92
OR 88X2,5	88	2.5	3.3	88	92.2	88.8	93
OR 89X2,5	89	2.5	3.3	89	93.2	89.8	94
OR 90X2,5	90	2.5	3.3	90	94.2	90.8	95
OR 92X2,5	92	2.5	3.3	92	96.2	92.8	97
OR 95X2,5	95	2.5	3.3	95	99.2	95.8	100
OR 96X2,5	96	2.5	3.3	96	100.2	96.8	101
OR 98X2,5	98	2.5	3.3	98	102.2	98.8	103
OR 102X2,5	102	2.5	3.3	102	106.2	102.8	107
OR 103X2,5	103	2.5	3.3	103	107.2	103.8	108
OR 105X2,5	105	2.5	3.3	105	109.2	105.8	110
OR 107X2,5	107	2.5	3.3	107	111.2	107.8	112
OR 108X2,5	108	2.5	3.3	108	112.2	108.8	113
OR 110X2,5	110	2.5	3.3	110	114.2	110.8	115
OR 111X2,5	111	2.5	3.3	111	115.2	111.8	116
OR 113X2,5	113	2.5	3.3	113	117.2	113.8	118

# OR

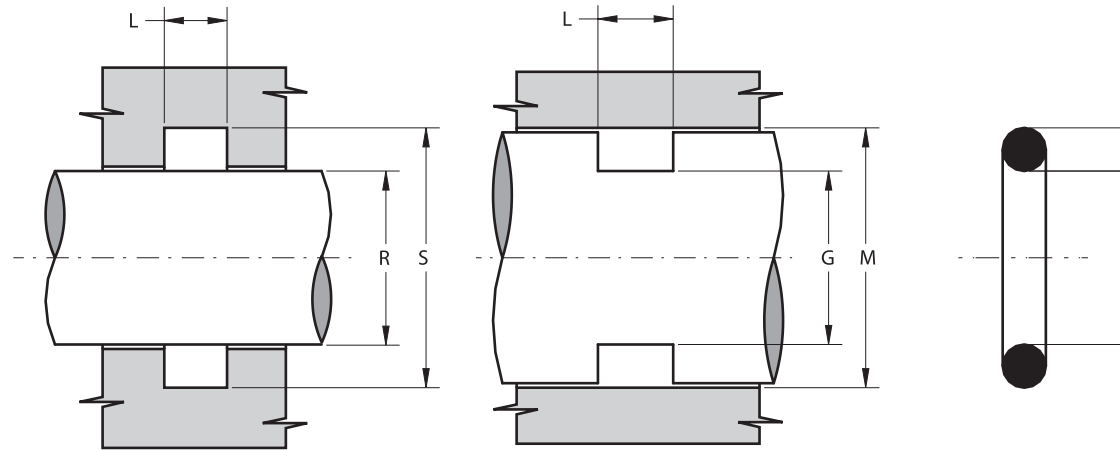

Cod. AS	d	c	L <sup>+0.2</sup>	R <sup>f7</sup>	S <sup>H9</sup>	G <sup>h9</sup>	M <sup>H8</sup>
<b>OR 115X2,5</b>	115	2.5	3.3	115	119.2	115.8	120
<b>OR 122X2,5</b>	122	2.5	3.3	122	126.2	122.8	127
<b>OR 124X2,5</b>	124	2.5	3.3	124	128.2	124.8	129
<b>OR 125X2,5</b>	125	2.5	3.3	125	129.2	125.8	130
<b>OR 127X2,5</b>	127	2.5	3.3	127	131.2	127.8	132
<b>OR 128X2,5</b>	128	2.5	3.3	128	132.2	128.8	133
<b>OR 130X2,5</b>	130	2.5	3.3	130	134.2	130.8	135
<b>OR 135X2,5</b>	135	2.5	3.3	135	139.2	135.8	140
<b>OR 140X2,5</b>	140	2.5	3.3	140	144.2	140.8	145
<b>OR 145X2,5</b>	145	2.5	3.3	145	149.2	145.8	150
<b>OR 150X2,5</b>	150	2.5	3.3	150	154.2	150.8	155
<b>OR 160X2,5</b>	160	2.5	3.3	160	164.2	160.8	165
<b>OR 3X3</b>	3	3	4	3	8	4	9
<b>OR 3,5X3</b>	3.5	3	4	3.5	8.5	4.5	9.5
<b>OR 4X3</b>	4	3	4	4	9	5	10
<b>OR 4,5X3</b>	4.5	3	4	4.5	9.5	5.5	10.5
<b>OR 5X3</b>	5	3	4	5	10	6	11
<b>OR 5,5X3</b>	5.5	3	4	5.5	10.5	6.5	11.5
<b>OR 6X3</b>	6	3	4	6	11	7	12
<b>OR 6,5X3</b>	6.5	3	4	6.5	11.5	7.5	12.5
<b>OR 7X3</b>	7	3	4	7	12	8	13
<b>OR 7,5X3</b>	7.5	3	4	7.5	12.5	8.5	13.5
<b>OR 8X3</b>	8	3	4	8	13	9	14

Cod. AS	d	c	L <sup>+0.2</sup>	R <sup>f7</sup>	S <sup>H9</sup>	G <sup>h9</sup>	M <sup>H8</sup>
<b>OR 8,5X3</b>	8.5	3	4	8.5	13.5	9.5	14.5
<b>OR 9X3</b>	9	3	4	9	14	10	15
<b>OR 9,5X3</b>	9.5	3	4	9.5	14.5	10.5	15.5
<b>OR 10X3</b>	10	3	4	10	15	11	16
<b>OR 10,5X3</b>	10.5	3	4	10	15	12	17
<b>OR 11X3</b>	11	3	4	11	16	12	17
<b>OR 11,5X3</b>	11.5	3	4	11	16	13	18
<b>OR 12X3</b>	12	3	4	12	17	13	18
<b>OR 12,5X3</b>	12.5	3	4	12	17	14	19
<b>OR 13X3</b>	13	3	4	13	18	14	19
<b>OR 13,5X3</b>	13.5	3	4	13	18	15	20
<b>OR 14X3</b>	14	3	4	14	19	15	20
<b>OR 14,5X3</b>	14.5	3	4	14	19	16	21
<b>OR 15X3</b>	15	3	4	15	20	16	21
<b>OR 15,5X3</b>	15.5	3	4	15	20	17	22
<b>OR 16X3</b>	16	3	4	16	21	17	22
<b>OR 16,5X3</b>	16.5	3	4	16	21	18	23
<b>OR 17X3</b>	17	3	4	17	22	18	23
<b>OR 17,5X3</b>	17.5	3	4	17	22	19	24
<b>OR 18X3</b>	18	3	4	18	23	19	24
<b>OR 18,5X3</b>	18.5	3	4	18	23	20	25
<b>OR 18,8X3</b>	18.8	3	4	18	23	20	25
<b>OR 19X3</b>	19	3	4	19	24	20	25
<b>OR 19,2X3</b>	19.2	3	4	19	24	21	26

Cod. AS	d	c	L <sup>+0.2</sup>	R <sup>f7</sup>	S <sup>H9</sup>	G <sup>h9</sup>	M <sup>H8</sup>
<b>OR 19,5X3</b>	19.5	3	4	19	24	21	26
<b>OR 20X3</b>	20	3	4	20	25	21	26
<b>OR 20,5X3</b>	20.5	3	4	20	25	22	27
<b>OR 21X3</b>	21	3	4	21	26	22	27
<b>OR 21,5X3</b>	21.5	3	4	21	26	23	28
<b>OR 22X3</b>	22	3	4	22	27	23	28
<b>OR 22,2X3</b>	22.2	3	4	22	27	24	29
<b>OR 22,5X3</b>	22.5	3	4	22	27	24	29
<b>OR 23X3</b>	23	3	4	23	28	24	29
<b>OR 23,5X3</b>	23.5	3	4	23	28	25	30
<b>OR 24X3</b>	24	3	4	24	29	25	30
<b>OR 24,2X3</b>	24.2	3	4	24	29	26	31
<b>OR 24,5X3</b>	24.5	3	4	24	29	26	31
<b>OR 24,6X3</b>	24.6	3	4	24	29	26	31
<b>OR 25X3</b>	25	3	4	25	30	26	31
<b>OR 25,5X3</b>	25.5	3	4	25	30	27	32
<b>OR 26X3</b>	26	3	4	26	31	27	32
<b>OR 26,2X3</b>	26.2	3	4	26	31	28	33
<b>OR 26,5X3</b>	26.5	3	4	26	31	28	33
<b>OR 27X3</b>	27	3	4	27	32	28	33
<b>OR 27,5X3</b>	27.5	3	4	27	32	29	34
<b>OR 27,5X3</b>	27.5	3	4	27	32	29	34
<b>OR 28X3</b>	28	3	4	28	33	29	34
<b>OR 28,5X3</b>	28.5	3	4	28	33	30	35

# OR

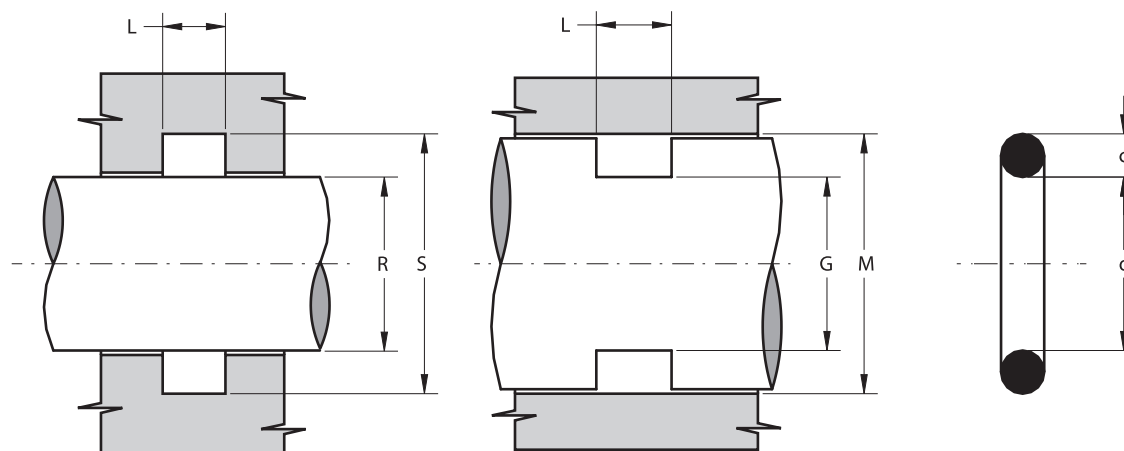

Cod. AS	d	c	L <sup>+0.2</sup>	R <sup>f7</sup>	S <sup>H9</sup>	G <sup>H9</sup>	M <sup>H8</sup>
OR 29X3	29	3	4	29	34	30	35
OR 29,2X3	29.2	3	4	29	34	31	36
OR 29,5X3	29.5	3	4	29	34	31	36
OR 30X3	30	3	4	30	35	31	36
OR 30,5X3	30.5	3	4	30	35	32	37
OR 31X3	31	3	4	31	36	32	37
OR 31,5X3	31.5	3	4	31	36	33	38
OR 32X3	32	3	4	32	37	33	38
OR 32,2X3	32.2	3	4	32	37	34	39
OR 32,5X3	32.5	3	4	32	37	34	39
OR 33X3	33	3	4	33	38	34	39
OR 33,5X3	33.5	3	4	33	38	35	40
OR 34X3	34	3	4	34	39	35	40
OR 34,2X3	34.2	3	4	34	39	36	41
OR 34,5X3	34.5	3	4	34	39	36	41
OR 35X3	35	3	4	35	40	36	41
OR 35,2X3	35.2	3	4	35	40	37	42
OR 35,5X3	35.5	3	4	35	40	37	42
OR 36X3	36	3	4	36	41	37	42
OR 36,2X3	36.2	3	4	36	41	38	43
OR 36,5X3	36.5	3	4	36	41	38	43
OR 37X3	37	3	4	37	42	38	43
OR 37,47X3	37.47	3	4	37	42	39	44
OR 37,5X3	37.5	3	4	37	42	39	44

Cod. AS	d	c	L <sup>+0.2</sup>	R <sup>f7</sup>	S <sup>H9</sup>	G <sup>H9</sup>	M <sup>H8</sup>
OR 38X3	38	3	4	38	43	39	44
OR 38,5X3	38.5	3	4	38	43	40	45
OR 39X3	39	3	4	39	44	40	45
OR 39,2X3	39.2	3	4	39	44	41	46
OR 39,5X3	39.5	3	4	39	44	41	46
OR 40X3	40	3	4	40	45	41	46
OR 41X3	41	3	4	41	46	42	47
OR 41,5X3	41.5	3	4	41	46	43	48
OR 42X3	42	3	4	42	47	43	48
OR 42,2X3	42.2	3	4	42	47	44	49
OR 42,5X3	42.5	3	4	42	47	44	49
OR 43X3	43	3	4	43	48	44	49
OR 43,69X3	43.69	3	4	43	48	45	50
OR 44X3	44	3	4	44	49	45	50
OR 44,2X3	44.2	3	4	44	49	46	51
OR 44,5X3	44.5	3	4	44	49	46	51
OR 45X3	45	3	4	45	50	46	51
OR 46X3	46	3	4	46	51	47	52
OR 47X3	47	3	4	47	52	48	53
OR 48X3	48	3	4	48	53	49	54
OR 49X3	49	3	4	49	54	50	55
OR 49,5X3	49.5	3	4	49	54	51	56
OR 50X3	50	3	4	50	55	51	56
OR 50,5X3	50.5	3	4	50	55	52	57

Cod. AS	d	c	L <sup>+0.2</sup>	R <sup>f7</sup>	S <sup>H9</sup>	G <sup>H9</sup>	M <sup>H8</sup>
OR 51X3	51	3	4	51	56	52	57
OR 52X3	52	3	4	52	57	53	58
OR 53X3	53	3	4	53	58	54	59
OR 53,09X3	53.09	3	4	53	58	55	60
OR 54X3	54	3	4	54	59	55	60
OR 54,5X3	54.5	3	4	54	59	56	61
OR 55X3	55	3	4	55	60	56	61
OR 56X3	56	3	4	56	61	57	62
OR 56,2X3	56.2	3	4	56	61	58	63
OR 57X3	57	3	4	57	62	58	63
OR 58X3	58	3	4	58	63	59	64
OR 59X3	59	3	4	59	64	60	65
OR 59,36X3	59.36	3	4	59	64	61	66
OR 59,5X3	59.5	3	4	59	64	61	66
OR 60X3	60	3	4	60	65	61	66
OR 61X3	61	3	4	61	66	62	67
OR 62X3	62	3	4	62	67	63	68
OR 63X3	63	3	4	63	68	64	69
OR 64X3	64	3	4	64	69	65	70
OR 64,5X3	64.5	3	4	64	69	66	71
OR 65X3	65	3	4	65	70	66	71
OR 66X3	66	3	4	66	71	67	72
OR 67X3	67	3	4	67	72	68	73
OR 68X3	68	3	4	68	73	69	74



# OR

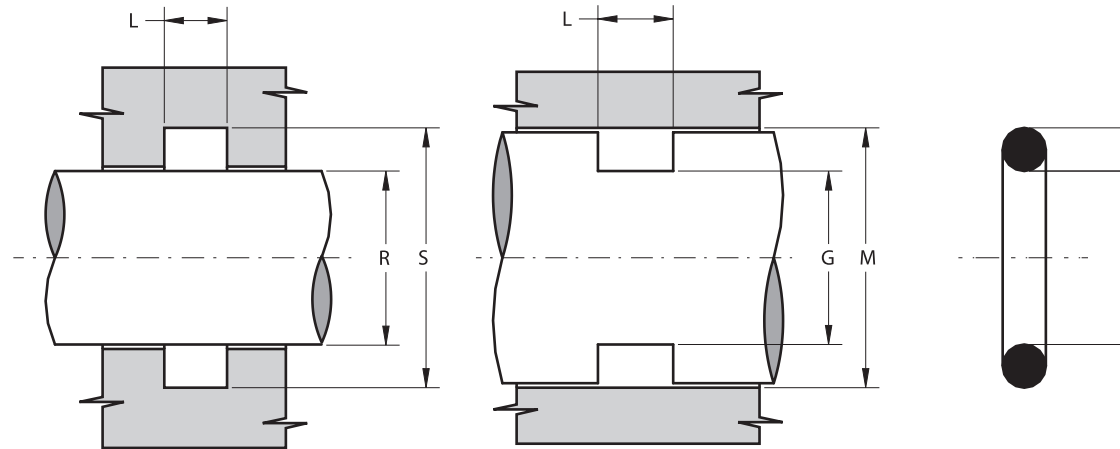

Cod. AS	d	c	L <sup>+0.2</sup>	R <sup>f7</sup>	S <sup>H9</sup>	G <sup>h9</sup>	M <sup>H8</sup>
<b>OR 69X3</b>	69	3	4	69	74	70	75
<b>OR 69,5X3</b>	69.5	3	4	69	74	71	76
<b>OR 70X3</b>	70	3	4	70	75	71	76
<b>OR 71X3</b>	71	3	4	71	76	72	77
<b>OR 72X3</b>	72	3	4	72	77	73	78
<b>OR 73X3</b>	73	3	4	73	78	74	79
<b>OR 74X3</b>	74	3	4	74	79	75	80
<b>OR 74,2X3</b>	74.2	3	4	74	79	76	81
<b>OR 74,5X3</b>	74.5	3	4	74	79	76	81
<b>OR 75X3</b>	75	3	4	75	80	76	81
<b>OR 76X3</b>	76	3	4	76	81	77	82
<b>OR 77X3</b>	77	3	4	77	82	78	83
<b>OR 78X3</b>	78	3	4	78	83	79	84
<b>OR 79X3</b>	79	3	4	79	84	80	85
<b>OR 79,2X3</b>	79.2	3	4	79	84	81	86
<b>OR 79,5X3</b>	79.5	3	4	79	84	81	86
<b>OR 80X3</b>	80	3	4	80	85	81	86
<b>OR 81X3</b>	81	3	4	81	86	82	87
<b>OR 82X3</b>	82	3	4	82	87	83	88
<b>OR 83X3</b>	83	3	4	83	88	84	89
<b>OR 84X3</b>	84	3	4	84	89	85	90
<b>OR 84,5X3</b>	84.5	3	4	84	89	86	91
<b>OR 85X3</b>	85	3	4	85	90	86	91
<b>OR 86X3</b>	86	3	4	86	91	87	92

Cod. AS	d	c	L <sup>+0.2</sup>	R <sup>f7</sup>	S <sup>H9</sup>	G <sup>h9</sup>	M <sup>H8</sup>
<b>OR 87X3</b>	87	3	4	87	92	88	93
<b>OR 88X3</b>	88	3	4	88	93	89	94
<b>OR 89X3</b>	89	3	4	89	94	90	95
<b>OR 89,5X3</b>	89.5	3	4	89	94	91	96
<b>OR 90X3</b>	90	3	4	90	95	91	96
<b>OR 91X3</b>	91	3	4	91	96	92	97
<b>OR 92X3</b>	92	3	4	92	97	93	98
<b>OR 93X3</b>	93	3	4	93	98	94	99
<b>OR 94X3</b>	94	3	4	94	99	95	100
<b>OR 94,5X3</b>	94.5	3	4	94	99	96	101
<b>OR 95X3</b>	95	3	4	95	100	96	101
<b>OR 96X3</b>	96	3	4	96	101	97	102
<b>OR 97X3</b>	97	3	4	97	102	98	103
<b>OR 98X3</b>	98	3	4	98	103	99	104
<b>OR 99X3</b>	99	3	4	99	104	100	105
<b>OR 99,5X3</b>	99.5	3	4	99	104	101	106
<b>OR 100X3</b>	100	3	4	100	105	101	106
<b>OR 102X3</b>	102	3	4	102	107	103	108
<b>OR 103X3</b>	103	3	4	103	108	104	109
<b>OR 104X3</b>	104	3	4	104	109	105	110
<b>OR 104,5X3</b>	104.5	3	4	104	109	106	111
<b>OR 105X3</b>	105	3	4	105	110	106	111
<b>OR 106X3</b>	106	3	4	106	111	107	112
<b>OR 108X3</b>	108	3	4	108	113	109	114

Cod. AS	d	c	L <sup>+0.2</sup>	R <sup>f7</sup>	S <sup>H9</sup>	G <sup>h9</sup>	M <sup>H8</sup>
<b>OR 109X3</b>	109	3	4	109	114	110	115
<b>OR 109,5X3</b>	109.5	3	4	109	114	111	116
<b>OR 110X3</b>	110	3	4	110	115	111	116
<b>OR 112X3</b>	112	3	4	112	117	113	118
<b>OR 113X3</b>	113	3	4	113	118	114	119
<b>OR 114X3</b>	114	3	4	114	119	115	120
<b>OR 114,5X3</b>	114.5	3	4	114	119	116	121
<b>OR 115X3</b>	115	3	4	115	120	116	121
<b>OR 116X3</b>	116	3	4	116	121	117	122
<b>OR 118X3</b>	118	3	4	118	123	119	124
<b>OR 119X3</b>	119	3	4	119	124	120	125
<b>OR 119,5X3</b>	119.5	3	4	119	124	121	126
<b>OR 120X3</b>	120	3	4	120	125	121	126
<b>OR 122X3</b>	122	3	4	122	127	123	128
<b>OR 123X3</b>	123	3	4	123	128	124	129
<b>OR 124X3</b>	124	3	4	124	129	125	130
<b>OR 124,5X3</b>	124.5	3	4	124	129	126	131
<b>OR 125X3</b>	125	3	4	125	130	126	131
<b>OR 126X3</b>	126	3	4	126	131	127	132
<b>OR 128X3</b>	128	3	4	128	133	129	134
<b>OR 129X3</b>	129	3	4	129	134	130	135
<b>OR 129,5X3</b>	129.5	3	4	129	134	131	136
<b>OR 130X3</b>	130	3	4	130	135	131	136
<b>OR 132X3</b>	132	3	4	132	137	133	138

# OR

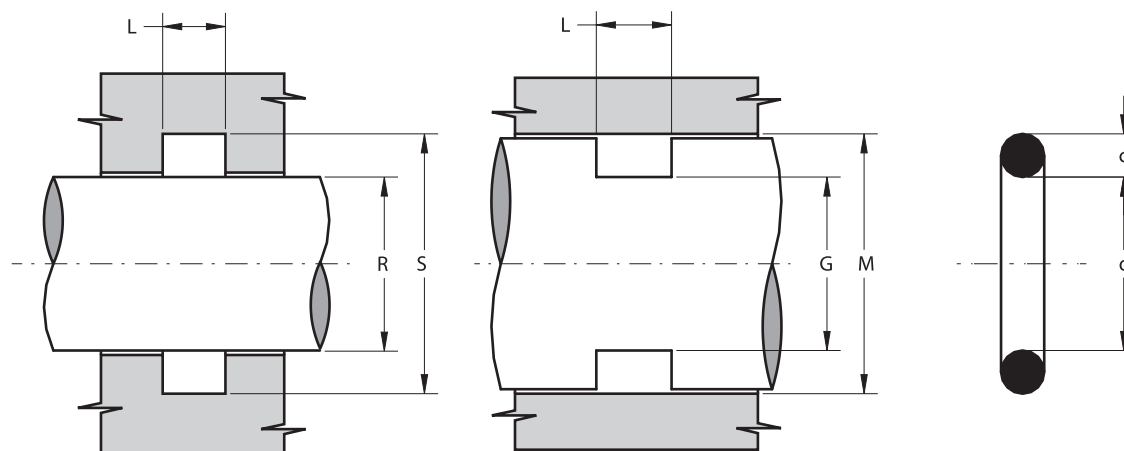

Cod. AS	d	c	L <sup>+0.2</sup>	R <sup>f7</sup>	S <sup>H9</sup>	G <sup>H9</sup>	M <sup>H8</sup>
<b>OR 134X3</b>	134	3	4	134	139	135	140
<b>OR 134,5X3</b>	134.5	3	4	134	139	136	141
<b>OR 135X3</b>	135	3	4	135	140	136	141
<b>OR 136X3</b>	136	3	4	136	141	137	142
<b>OR 137X3</b>	137	3	4	137	142	138	143
<b>OR 138X3</b>	138	3	4	138	143	139	144
<b>OR 139X3</b>	139	3	4	139	144	140	145
<b>OR 139,5X3</b>	139.5	3	4	139	144	141	146
<b>OR 140X3</b>	140	3	4	140	145	141	146
<b>OR 142X3</b>	142	3	4	142	147	143	148
<b>OR 143X3</b>	143	3	4	143	148	144	149
<b>OR 144X3</b>	144	3	4	144	149	145	150
<b>OR 144,5X3</b>	144.5	3	4	144	149	146	151
<b>OR 145X3</b>	145	3	4	145	150	146	151
<b>OR 147X3</b>	147	3	4	147	152	148	153
<b>OR 148X3</b>	148	3	4	148	153	149	154
<b>OR 149X3</b>	149	3	4	149	154	150	155
<b>OR 149,5X3</b>	149.5	3	4	149	154	151	156
<b>OR 150X3</b>	150	3	4	150	155	151	156
<b>OR 151X3</b>	151	3	4	150	155	152	157
<b>OR 152X3</b>	152	3	4	150	155	153	158
<b>OR 154X3</b>	154	3	4	150	155	155	160
<b>OR 154,5X3</b>	154.5	3	4	150	155	160	165
<b>OR 160X3</b>	160	3	4	160	165	165	170

Cod. AS	d	c	L <sup>+0.2</sup>	R <sup>f7</sup>	S <sup>H9</sup>	G <sup>H9</sup>	M <sup>H8</sup>
<b>OR 161X3</b>	161	3	4	160	165	165	170
<b>OR 164,5X3</b>	164.5	3	4	160	165	170	175
<b>OR 165X3</b>	165	3	4	165	170	170	175
<b>OR 168X3</b>	168	3	4	165	170	170	175
<b>OR 170X3</b>	170	3	4	170	175	175	180
<b>OR 174X3</b>	174	3	4	170	175	175	180
<b>OR 175X3</b>	175	3	4	175	180	180	185
<b>OR 178X3</b>	178	3	4	175	180	180	185
<b>OR 179X3</b>	179	3	4	175	180	180	185
<b>OR 184X3</b>	184	3	4	180	185	185	190
<b>OR 184,5X3</b>	184.5	3	4	180	185	190	195
<b>OR 190X3</b>	190	3	4	190	195	195	200
<b>OR 192X3</b>	192	3	4	190	195	195	200
<b>OR 194X3</b>	194	3	4	190	195	195	200
<b>OR 194,5X3</b>	194.5	3	4	190	195	200	205
<b>OR 197,5X3</b>	197.5	3	4	195	200	200	205
<b>OR 200X3</b>	200	3	4	200	205	205	210
<b>OR 206X3</b>	206	3	4	205	210	210	215
<b>OR 215X3</b>	215	3	4	215	220	220	225
<b>OR 220X3</b>	220	3	4	220	225	225	230
<b>OR 224X3</b>	224	3	4	220	225	225	230
<b>OR 228X3</b>	228	3	4	225	230	230	235
<b>OR 233X3</b>	233	3	4	230	235	235	240
<b>OR 235X3</b>	235	3	4	235	240	240	245

Cod. AS	d	c	L <sup>+0.2</sup>	R <sup>f7</sup>	S <sup>H9</sup>	G <sup>H9</sup>	M <sup>H8</sup>
<b>OR 240X3</b>	240	3	4	240	245	245	250
<b>OR 248X3</b>	248	3	4	245	250	250	255
<b>OR 251X3</b>	251	3	4	250	255	255	260
<b>OR 279X3</b>	279	3	4	275	280	280	285
<b>OR 280X3</b>	280	3	4	280	285	285	290
<b>OR 281X3</b>	281	3	4	280	285	285	290
<b>OR 285X3</b>	285	3	4	285	290	290	295
<b>OR 310X3</b>	310	3	4	310	315	315	320
<b>OR 340X3</b>	340	3	4	340	345	345	350
<b>OR 430X3</b>	430	3	4	430	435	435	440
<b>OR 450X3</b>	450	3	4	450	455	455	460
<b>OR 4X4</b>	4	4	5.2	4	11	5	12
<b>OR 5X4</b>	5	4	5.2	5	12	6	13
<b>OR 6X4</b>	6	4	5.2	6	13	7	14
<b>OR 7X4</b>	7	4	5.2	7	14	8	15
<b>OR 8X4</b>	8	4	5.2	8	15	9	16
<b>OR 9X4</b>	9	4	5.2	9	16	10	17
<b>OR 10X4</b>	10	4	5.2	10	17	11	18
<b>OR 11X4</b>	11	4	5.2	11	18	12	19
<b>OR 12X4</b>	12	4	5.2	12	19	13	20
<b>OR 13X4</b>	13	4	5.2	13	20	14	21
<b>OR 14X4</b>	14	4	5.2	14	21	15	22
<b>OR 15X4</b>	15	4	5.2	15	22	16	23

# OR

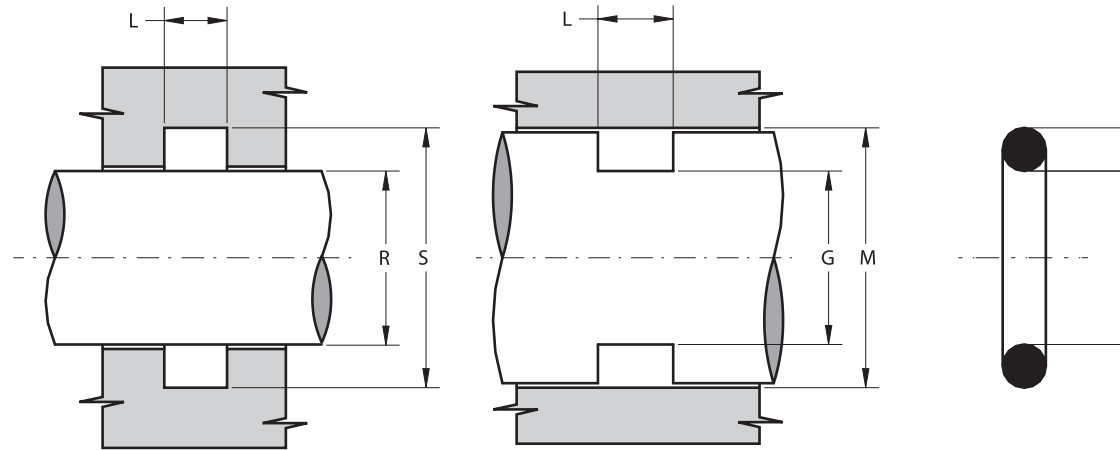

Cod. AS	d	c	L <sup>+0.2</sup>	R <sup>f7</sup>	S <sup>H9</sup>	G <sup>h9</sup>	M <sup>H8</sup>
OR 16X4	16	4	5.2	16	23	17	24
OR 17X4	17	4	5.2	17	24	18	25
OR 18X4	18	4	5.2	18	25	19	26
OR 19X4	19	4	5.2	19	26	20	27
OR 20X4	20	4	5.2	20	27	21	28
OR 21X4	21	4	5.2	21	28	22	29
OR 22X4	22	4	5.2	22	29	23	30
OR 23X4	23	4	5.2	23	30	24	31
OR 24X4	24	4	5.2	24	31	25	32
OR 25X4	25	4	5.2	25	32	26	33
OR 26X4	26	4	5.2	26	33	27	34
OR 27X4	27	4	5.2	27	34	28	35
OR 28X4	28	4	5.2	28	35	29	36
OR 29X4	29	4	5.2	29	36	30	37
OR 30X4	30	4	5.2	30	37	31	38
OR 31X4	31	4	5.2	31	38	32	39
OR 32X4	32	4	5.2	32	39	33	40
OR 33X4	33	4	5.2	33	40	34	41
OR 33,5X4	33.5	4	5.2	33	40	35	42
OR 34X4	34	4	5.2	34	41	35	42
OR 35X4	35	4	5.2	35	42	36	43
OR 36X4	36	4	5.2	36	43	37	44
OR 37X4	37	4	5.2	37	44	38	45
OR 38X4	38	4	5.2	38	45	39	46

Cod. AS	d	c	L <sup>+0.2</sup>	R <sup>f7</sup>	S <sup>H9</sup>	G <sup>h9</sup>	M <sup>H8</sup>
OR 39X4	39	4	5.2	39	46	40	47
OR 40X4	40	4	5.2	40	47	41	48
OR 41X4	41	4	5.2	41	48	42	49
OR 42X4	42	4	5.2	42	49	43	50
OR 43X4	43	4	5.2	43	50	44	51
OR 44X4	44	4	5.2	44	51	45	52
OR 45X4	45	4	5.2	45	52	46	53
OR 46X4	46	4	5.2	46	53	47	54
OR 47X4	47	4	5.2	47	54	48	55
OR 48X4	48	4	5.2	48	55	49	56
OR 49X4	49	4	5.2	49	56	50	57
OR 50X4	50	4	5.2	50	57	51	58
OR 51X4	51	4	5.2	51	58	52	59
OR 52X4	52	4	5.2	52	59	53	60
OR 53X4	53	4	5.2	53	60	54	61
OR 54X4	54	4	5.2	54	61	55	62
OR 55X4	55	4	5.2	55	62	56	63
OR 56X4	56	4	5.2	56	63	57	64
OR 57X4	57	4	5.2	57	64	58	65
OR 58X4	58	4	5.2	58	65	59	66
OR 59X4	59	4	5.2	59	66	60	67
OR 60X4	60	4	5.2	60	67	61	68
OR 61X4	61	4	5.2	61	68	62	69
OR 62X4	62	4	5.2	62	69	63	70

Cod. AS	d	c	L <sup>+0.2</sup>	R <sup>f7</sup>	S <sup>H9</sup>	G <sup>h9</sup>	M <sup>H8</sup>
OR 63X4	63	4	5.2	63	70	64	71
OR 64X4	64	4	5.2	64	71	65	72
OR 65X4	65	4	5.2	65	72	66	73
OR 66X4	66	4	5.2	66	73	67	74
OR 67,5X4	67.5	4	5.2	67	74	69	76
OR 68X4	68	4	5.2	68	75	69	76
OR 69X4	69	4	5.2	69	76	70	77
OR 70X4	70	4	5.2	70	77	71	78
OR 71X4	71	4	5.2	71	78	72	79
OR 72X4	72	4	5.2	72	79	73	80
OR 72,5X4	72.5	4	5.2	72	79	74	81
OR 73X4	73	4	5.2	73	80	74	81
OR 74X4	74	4	5.2	74	81	75	82
OR 75X4	75	4	5.2	75	82	76	83
OR 76X4	76	4	5.2	76	83	77	84
OR 77X4	77	4	5.2	77	84	78	85
OR 78X4	78	4	5.2	78	85	79	86
OR 79X4	79	4	5.2	79	86	80	87
OR 80X4	80	4	5.2	80	87	81	88
OR 81X4	81	4	5.2	81	88	82	89
OR 82X4	82	4	5.2	82	89	83	90
OR 83X4	83	4	5.2	83	90	84	91
OR 84X4	84	4	5.2	84	91	85	92
OR 85X4	85	4	5.2	85	92	86	93

# OR

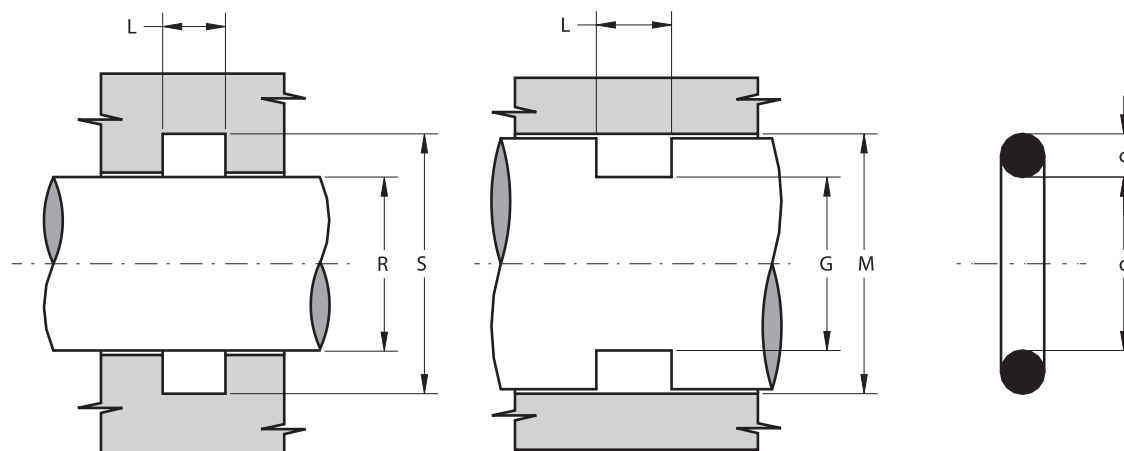

Cod. AS	d	c	L <sup>+0.2</sup>	R <sup>f7</sup>	S <sup>H9</sup>	G <sup>H9</sup>	M <sup>H8</sup>
OR 86X4	86	4	5.2	86	93	87	94
OR 87X4	87	4	5.2	87	94	88	95
OR 88X4	88	4	5.2	88	95	89	96
OR 89X4	89	4	5.2	89	96	90	97
OR 90X4	90	4	5.2	90	97	91	98
OR 91X4	91	4	5.2	91	98	92	99
OR 92X4	92	4	5.2	92	99	93	100
OR 93X4	93	4	5.2	93	100	94	101
OR 94X4	94	4	5.2	94	101	95	102
OR 95X4	95	4	5.2	95	102	96	103
OR 96X4	96	4	5.2	96	103	97	104
OR 97X4	97	4	5.2	97	104	98	105
OR 98X4	98	4	5.2	98	105	99	106
OR 99X4	99	4	5.2	99	106	100	107
OR 100X4	100	4	5.2	100	107	101	108
OR 102X4	102	4	5.2	102	109	103	110
OR 103X4	103	4	5.2	103	110	104	111
OR 104X4	104	4	5.2	104	111	105	112
OR 105X4	105	4	5.2	105	112	106	113
OR 106X4	106	4	5.2	106	113	107	114
OR 108X4	108	4	5.2	108	115	109	116
OR 109X4	109	4	5.2	109	116	110	117
OR 110X4	110	4	5.2	110	117	111	118
OR 112X4	112	4	5.2	112	119	113	120

Cod. AS	d	c	L <sup>+0.2</sup>	R <sup>f7</sup>	S <sup>H9</sup>	G <sup>H9</sup>	M <sup>H8</sup>
OR 114X4	114	4	5.2	114	121	115	122
OR 115X4	115	4	5.2	115	122	116	123
OR 117X4	117	4	5.2	117	124	118	125
OR 118X4	118	4	5.2	118	125	119	126
OR 119X4	119	4	5.2	119	126	120	127
OR 120X4	120	4	5.2	120	127	121	128
OR 122X4	122	4	5.2	122	129	123	130
OR 124X4	124	4	5.2	124	131	125	132
OR 125X4	125	4	5.2	125	132	126	133
OR 126X4	126	4	5.2	126	133	127	134
OR 127X4	127	4	5.2	127	134	128	135
OR 128X4	128	4	5.2	128	135	129	136
OR 129X4	129	4	5.2	129	136	130	137
OR 130X4	130	4	5.2	130	137	131	138
OR 131X4	131	4	5.2	131	138	132	139
OR 132X4	132	4	5.2	132	139	133	140
OR 133X4	133	4	5.2	133	140	134	141
OR 134X4	134	4	5.2	134	141	135	142
OR 135X4	135	4	5.2	135	142	136	143
OR 139X4	139	4	5.2	139	146	140	147
OR 140X4	140	4	5.2	140	147	141	148
OR 143X4	143	4	5.2	143	150	144	151
OR 144X4	144	4	5.2	144	151	145	152
OR 145X4	145	4	5.2	145	152	146	153

Cod. AS	d	c	L <sup>+0.2</sup>	R <sup>f7</sup>	S <sup>H9</sup>	G <sup>H9</sup>	M <sup>H8</sup>
OR 146X4	146	4	5.2	146	153	147	154
OR 150X4	150	4	5.2	150	157	151	158
OR 152X4	152	4	5.2	150	157	153	160
OR 158X4	158	4	5.2	155	162	163	170
OR 158,4X4	158.4	4	5.2	155	162	163	170
OR 160X4	160	4	5.2	160	167	163	170
OR 163X4	163	4	5.2	160	167	168	175
OR 165X4	165	4	5.2	165	172	168	175
OR 168X4	168	4	5.2	165	172	173	180
OR 170X4	170	4	5.2	170	177	173	180
OR 172X4	172	4	5.2	170	177	173	180
OR 173X4	173	4	5.2	170	177	178	185
OR 180X4	180	4	5.2	180	187	183	190
OR 188X4	188	4	5.2	185	192	193	200
OR 190X4	190	4	5.2	190	197	193	200
OR 192X4	192	4	5.2	190	197	193	200
OR 194X4	194	4	5.2	190	197	198	205
OR 205X4	205	4	5.2	205	212	208	215
OR 208X4	208	4	5.2	205	212	213	220
OR 210X4	210	4	5.2	210	217	213	220
OR 220X4	220	4	5.2	220	227	223	230
OR 225X4	225	4	5.2	225	232	228	235
OR 250X4	250	4	5.2	250	257	253	260
OR 255X4	255	4	5.2	255	262	258	265

# OR

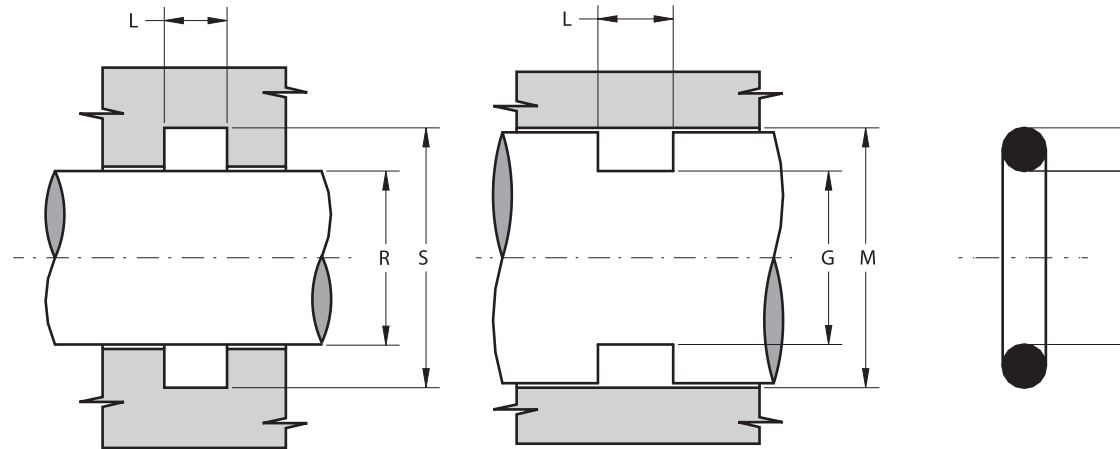

Cod. AS	d	c	L <sup>+0.2</sup>	R <sup>f7</sup>	S <sup>H9</sup>	G <sup>h9</sup>	M <sup>H8</sup>
<b>OR 260X4</b>	260	4	5.2	260	267	263	270
<b>OR 262X4</b>	262	4	5.2	260	267	263	270
<b>OR 270X4</b>	270	4	5.2	270	277	273	280
<b>OR 293X4</b>	293	4	5.2	290	297	298	305
<b>OR 295X4</b>	295	4	5.2	295	302	298	305
<b>OR 296X4</b>	296	4	5.2	295	302	298	305
<b>OR 297X4</b>	297	4	5.2	295	302	298	305
<b>OR 323X4</b>	323	4	5.2	320	327	328	335
<b>OR 335X4</b>	335	4	5.2	335	342	338	345
<b>OR 355X4</b>	355	4	5.2	355	362	358	365
<b>OR 15X4,5</b>	15	4.5	5.8	15	22.8	16.2	24
<b>OR 16X4,5</b>	16	4.5	5.8	16	23.8	17.2	25
<b>OR 20X4,5</b>	20	4.5	5.8	20	27.8	21.2	29
<b>OR 22X4,5</b>	22	4.5	5.8	22	29.8	23.2	31
<b>OR 23X4,5</b>	23	4.5	5.8	23	30.8	24.2	32
<b>OR 25X4,5</b>	25	4.5	5.8	25	32.8	26.2	34
<b>OR 27X4,5</b>	27	4.5	5.8	27	34.8	28.2	36
<b>OR 30X4,5</b>	30	4.5	5.8	30	37.8	31.2	39
<b>OR 31X4,5</b>	31	4.5	5.8	31	38.8	32.2	40
<b>OR 36X4,5</b>	36	4.5	5.8	36	43.8	37.2	45
<b>OR 57X4,5</b>	57	4.5	5.8	57	64.8	58.2	66
<b>OR 60X4,5</b>	60	4.5	5.8	60	67.8	61.2	69
<b>OR 70X4,5</b>	70	4.5	5.8	70	77.8	71.2	79

Cod. AS	d	c	L <sup>+0.2</sup>	R <sup>f7</sup>	S <sup>H9</sup>	G <sup>h9</sup>	M <sup>H8</sup>
<b>OR 89X4,5</b>	89	4.5	5.8	89	96.8	90.2	98
<b>OR 150X4,5</b>	150	4.5	5.8	150	157.8	151.2	159
<b>OR 6X5</b>	6	5	6.6	6	14.7	7.3	16
<b>OR 8X5</b>	8	5	6.6	8	16.7	9.3	18
<b>OR 9X5</b>	9	5	6.6	9	17.7	10.3	19
<b>OR 10X5</b>	10	5	6.6	10	18.7	11.3	20
<b>OR 11X5</b>	11	5	6.6	11	19.7	12.3	21
<b>OR 12X5</b>	12	5	6.6	12	20.7	13.3	22
<b>OR 13X5</b>	13	5	6.6	13	21.7	14.3	23
<b>OR 14X5</b>	14	5	6.6	14	22.7	15.3	24
<b>OR 15X5</b>	15	5	6.6	15	23.7	16.3	25
<b>OR 16X5</b>	16	5	6.6	16	24.7	17.3	26
<b>OR 17X5</b>	17	5	6.6	17	25.7	18.3	27
<b>OR 18X5</b>	18	5	6.6	18	26.7	19.3	28
<b>OR 19X5</b>	19	5	6.6	19	27.7	20.3	29
<b>OR 20X5</b>	20	5	6.6	20	28.7	21.3	30
<b>OR 21X5</b>	21	5	6.6	21	29.7	22.3	31
<b>OR 22X5</b>	22	5	6.6	22	30.7	23.3	32
<b>OR 23X5</b>	23	5	6.6	23	31.7	24.3	33
<b>OR 24X5</b>	24	5	6.6	24	32.7	25.3	34
<b>OR 25X5</b>	25	5	6.6	25	33.7	26.3	35
<b>OR 26X5</b>	26	5	6.6	26	34.7	27.3	36
<b>OR 27X5</b>	27	5	6.6	27	35.7	28.3	37

Cod. AS	d	c	L <sup>+0.2</sup>	R <sup>f7</sup>	S <sup>H9</sup>	G <sup>h9</sup>	M <sup>H8</sup>
<b>OR 28X5</b>	28	5	6.6	28	36.7	29.3	38
<b>OR 29X5</b>	29	5	6.6	29	37.7	30.3	39
<b>OR 30X5</b>	30	5	6.6	30	38.7	31.3	40
<b>OR 31X5</b>	31	5	6.6	31	39.7	32.3	41
<b>OR 32X5</b>	32	5	6.6	32	40.7	33.3	42
<b>OR 33X5</b>	33	5	6.6	33	41.7	34.3	43
<b>OR 34X5</b>	34	5	6.6	34	42.7	35.3	44
<b>OR 35X5</b>	35	5	6.6	35	43.7	36.3	45
<b>OR 36X5</b>	36	5	6.6	36	44.7	37.3	46
<b>OR 37X5</b>	37	5	6.6	37	45.7	38.3	47
<b>OR 38X5</b>	38	5	6.6	38	46.7	39.3	48
<b>OR 39X5</b>	39	5	6.6	39	47.7	40.3	49
<b>OR 40X5</b>	40	5	6.6	40	48.7	41.3	50
<b>OR 41X5</b>	41	5	6.6	41	49.7	42.3	51
<b>OR 42X5</b>	42	5	6.6	42	50.7	43.3	52
<b>OR 43X5</b>	43	5	6.6	43	51.7	44.3	53
<b>OR 44X5</b>	44	5	6.6	44	52.7	45.3	54
<b>OR 45X5</b>	45	5	6.6	45	53.7	46.3	55
<b>OR 46X5</b>	46	5	6.6	46	54.7	47.3	56
<b>OR 47X5</b>	47	5	6.6	47	55.7	48.3	57
<b>OR 48X5</b>	48	5	6.6	48	56.7	49.3	58
<b>OR 50X5</b>	50	5	6.6	50	58.7	51.3	60
<b>OR 51X5</b>	51	5	6.6	51	59.7	52.3	61
<b>OR 52X5</b>	52	5	6.6	52	60.7	53.3	62

# OR

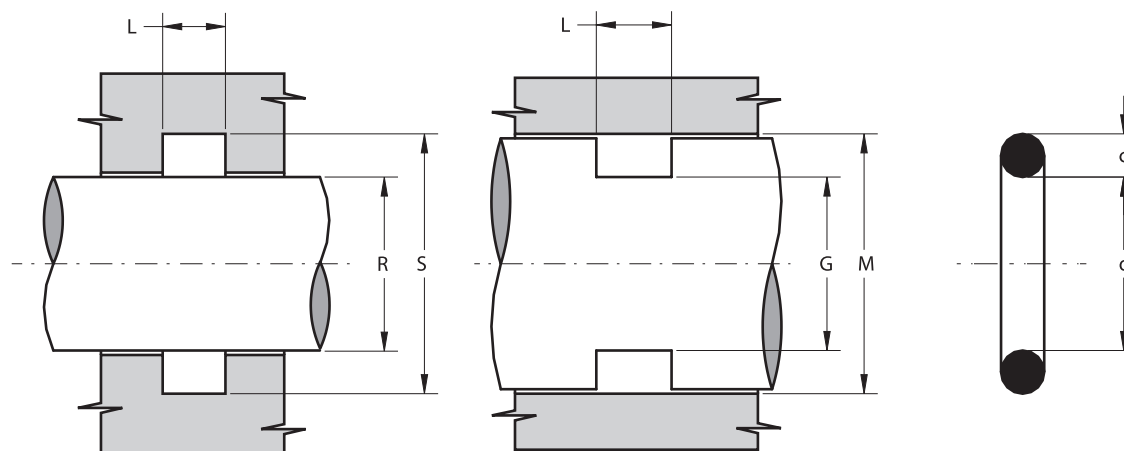

Cod. AS	d	c	L <sup>+0.2</sup>	R <sup>f7</sup>	S <sup>H9</sup>	G <sup>H9</sup>	M <sup>H8</sup>
OR 53X5	53	5	6.6	53	61.7	54.3	63
OR 54X5	54	5	6.6	54	62.7	55.3	64
OR 55X5	55	5	6.6	55	63.7	56.3	65
OR 57X5	57	5	6.6	57	65.7	58.3	67
OR 58X5	58	5	6.6	58	66.7	59.3	68
OR 59X5	59	5	6.6	59	67.7	60.3	69
OR 60X5	60	5	6.6	60	68.7	61.3	70
OR 61X5	61	5	6.6	61	69.7	62.3	71
OR 62X5	62	5	6.6	62	70.7	63.3	72
OR 63X5	63	5	6.6	63	71.7	64.3	73
OR 65X5	65	5	6.6	65	73.7	66.3	75
OR 66X5	66	5	6.6	66	74.7	67.3	76
OR 67X5	67	5	6.6	67	75.7	68.3	77
OR 68X5	68	5	6.6	68	76.7	69.3	78
OR 70X5	70	5	6.6	70	78.7	71.3	80
OR 71X5	71	5	6.6	71	79.7	72.3	81
OR 72X5	72	5	6.6	72	80.7	73.3	82
OR 74X5	74	5	6.6	74	82.7	75.3	84
OR 75X5	75	5	6.6	75	83.7	76.3	85
OR 76X5	76	5	6.6	76	84.7	77.3	86
OR 77X5	77	5	6.6	77	85.7	78.3	87
OR 78X5	78	5	6.6	78	86.7	79.3	88
OR 79X5	79	5	6.6	79	87.7	80.3	89
OR 80X5	80	5	6.6	80	88.7	81.3	90

Cod. AS	d	c	L <sup>+0.2</sup>	R <sup>f7</sup>	S <sup>H9</sup>	G <sup>H9</sup>	M <sup>H8</sup>
OR 84X5	84	5	6.6	84	92.7	85.3	94
OR 85X5	85	5	6.6	85	93.7	86.3	95
OR 86X5	86	5	6.6	86	94.7	87.3	96
OR 87X5	87	5	6.6	87	95.7	88.3	97
OR 88X5	88	5	6.6	88	96.7	89.3	98
OR 90X5	90	5	6.6	90	98.7	91.3	100
OR 91X5	91	5	6.6	91	99.7	92.3	101
OR 93X5	93	5	6.6	93	101.7	94.3	103
OR 95X5	95	5	6.6	95	103.7	96.3	105
OR 96X5	96	5	6.6	96	104.7	97.3	106
OR 97X5	97	5	6.6	97	105.7	98.3	107
OR 98X5	98	5	6.6	98	106.7	99.3	108
OR 100X5	100	5	6.6	100	108.7	101.3	110
OR 105X5	105	5	6.6	105	113.7	106.3	115
OR 112X5	112	5	6.6	112	120.7	113.3	122
OR 115X5	115	5	6.6	115	123.7	116.3	125
OR 116X5	116	5	6.6	116	124.7	117.3	126
OR 118X5	118	5	6.6	118	126.7	119.3	128
OR 120X5	120	5	6.6	120	128.7	121.3	130
OR 122X5	122	5	6.6	122	130.7	123.3	132
OR 125X5	125	5	6.6	125	133.7	126.3	135
OR 132X5	132	5	6.6	132	140.7	133.3	142
OR 135X5	135	5	6.6	135	143.7	136.3	145
OR 140X5	140	5	6.6	140	148.7	141.3	150

Cod. AS	d	c	L <sup>+0.2</sup>	R <sup>f7</sup>	S <sup>H9</sup>	G <sup>H9</sup>	M <sup>H8</sup>
OR 145X5	145	5	6.6	145	153.7	146.3	155
OR 148X5	148	5	6.6	148	156.7	149.3	158
OR 160X5	160	5	6.6	160	168.7	161.3	170
OR 164X5	164	5	6.6	160	168.7	166.3	175
OR 165X5	165	5	6.6	165	173.7	166.3	175
OR 170X5	170	5	6.6	170	178.7	171.3	180
OR 175X5	175	5	6.6	175	183.7	176.3	185
OR 180X5	180	5	6.6	180	188.7	181.3	190
OR 182X5	182	5	6.6	180	188.7	186.3	195
OR 185X5	185	5	6.6	185	193.7	186.3	195
OR 190X5	190	5	6.6	190	198.7	191.3	200
OR 196X5	196	5	6.6	195	203.7	201.3	210
OR 204X5	204	5	6.6	200	208.7	206.3	215
OR 205X5	205	5	6.6	205	213.7	206.3	215
OR 210X5	210	5	6.6	210	218.7	211.3	220
OR 215X5	215	5	6.6	215	223.7	216.3	225
OR 220X5	220	5	6.6	220	228.7	221.3	230
OR 225X5	225	5	6.6	225	233.7	226.3	235
OR 230X5	230	5	6.6	230	238.7	231.3	240
OR 234X5	234	5	6.6	230	238.7	236.3	245
OR 240X5	240	5	6.6	240	248.7	241.3	250
OR 245X5	245	5	6.6	245	253.7	246.3	255
OR 250X5	250	5	6.6	250	258.7	251.3	260
OR 255X5	255	5	6.6	255	263.7	256.3	265

# OR

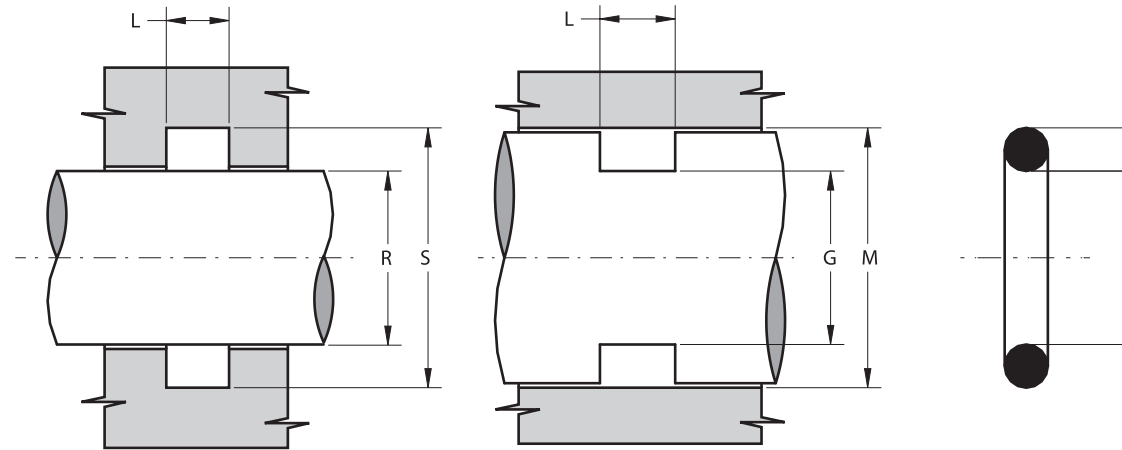

Cod. AS	d	c	L <sup>+0.2</sup>	R <sup>f7</sup>	S <sup>H9</sup>	G <sup>h9</sup>	M <sup>H8</sup>
OR 260X5	260	5	6.6	260	268.7	261.3	270
OR 270X5	270	5	6.6	270	278.7	271.3	280
OR 280X5	280	5	6.6	280	288.7	281.3	290
OR 290X5	290	5	6.6	290	298.7	291.3	300
OR 295X5	295	5	6.6	295	303.7	296.3	305
OR 307X5	307	5	6.6	305	313.7	311.3	320
OR 310X5	310	5	6.6	310	318.7	311.3	320
OR 315X5	315	5	6.6	315	323.7	316.3	325
OR 350X5	350	5	6.6	350	358.7	351.3	360
OR 520X5	520	5	6.6	520	528.7	521.3	530
OR 41,2X5,7	41.2	5.7	7.2	41	51	43	53
OR 44,2X5,7	44.2	5.7	7.2	44	54	46	56
OR 44,3X5,7	44.3	5.7	7.2	44	54	46	56
OR 45,3X5,7	45.3	5.7	7.2	45	55	47	57
OR 49,2X5,7	49.2	5.7	7.2	49	59	51	61
OR 52,3X5,7	52.3	5.7	7.2	52	62	54	64
OR 52,5X5,7	52.5	5.7	7.2	52	62	54	64
OR 54,2X5,7	54.2	5.7	7.2	54	64	56	66
OR 54,3X5,7	54.3	5.7	7.2	54	64	56	66
OR 55,3X5,7	55.3	5.7	7.2	55	65	57	67
OR 57,2X5,7	57.2	5.7	7.2	57	67	59	69
OR 59,2X5,7	59.2	5.7	7.2	59	69	61	71
OR 59,7X5,7	59.7	5.7	7.2	59	69	62	72

Cod. AS	d	c	L <sup>+0.2</sup>	R <sup>f7</sup>	S <sup>H9</sup>	G <sup>h9</sup>	M <sup>H8</sup>
OR 62,3X5,7	62.3	5.7	7.2	62	72	64	74
OR 64,2X5,7	64.2	5.7	7.2	64	74	66	76
OR 64,3X5,7	64.3	5.7	7.2	64	74	66	76
OR 69X5,7	69	5.7	7.2	69	79	71	81
OR 69,2X5,7	69.2	5.7	7.2	69	79	71	81
OR 69,3X5,7	69.3	5.7	7.2	69	79	71	81
OR 74,3X5,7	74.3	5.7	7.2	74	84	76	86
OR 79X5,7	79	5.7	7.2	79	89	81	91
OR 79,3X5,7	79.3	5.7	7.2	79	89	81	91
OR 84,3X5,7	84.3	5.7	7.2	84	94	86	96
OR 89X5,7	89	5.7	7.2	89	99	91	101
OR 89,1X5,7	89.1	5.7	7.2	89	99	91	101
OR 89,3X5,7	89.3	5.7	7.2	89	99	91	101
OR 94,3X5,7	94.3	5.7	7.2	94	104	96	106
OR 99X5,7	99	5.7	7.2	99	109	101	111
OR 99,3X5,7	99.3	5.7	7.2	99	109	101	111
OR 104X5,7	104	5.7	7.2	104	114	106	116
OR 104,3X5,7	104.3	5.7	7.2	104	114	106	116
OR 109X5,7	109	5.7	7.2	109	119	111	121
OR 109,3X5,7	109.3	5.7	7.2	109	119	111	121
OR 114,3X5,7	114.3	5.7	7.2	114	124	116	126
OR 119X5,7	119	5.7	7.2	119	129	121	131
OR 119,3X5,7	119.3	5.7	7.2	119	129	121	131
OR 124X5,7	124	5.7	7.2	124	134	126	136

Cod. AS	d	c	L <sup>+0.2</sup>	R <sup>f7</sup>	S <sup>H9</sup>	G <sup>h9</sup>	M <sup>H8</sup>
OR 124,3X5,7	124.3	5.7	7.2	124	134	126	136
OR 129X5,7	129	5.7	7.2	129	139	131	141
OR 129,3X5,7	129.3	5.7	7.2	129	139	131	141
OR 134,3X5,7	134.3	5.7	7.2	134	144	136	146
OR 139,3X5,7	139.3	5.7	7.2	139	149	141	151
OR 139,5X5,7	139.5	5.7	7.2	139	149	141	151
OR 144,3X5,7	144.3	5.7	7.2	144	154	146	156
OR 149,3X5,7	149.3	5.7	7.2	149	159	151	161
OR 154,3X5,7	154.3	5.7	7.2	150	160	160	170
OR 159,3X5,7	159.3	5.7	7.2	155	165	165	175
OR 164,3X5,7	164.3	5.7	7.2	160	170	170	180
OR 169,3X5,7	169.3	5.7	7.2	165	175	175	185
OR 174,3X5,7	174.3	5.7	7.2	170	180	180	190
OR 179,3X5,7	179.3	5.7	7.2	175	185	185	195
OR 184,3X5,7	184.3	5.7	7.2	180	190	190	200
OR 189,3X5,7	189.3	5.7	7.2	185	195	195	205
OR 194,3X5,7	194.3	5.7	7.2	190	200	200	210
OR 199,3X5,7	199.3	5.7	7.2	195	205	205	215
OR 209,3X5,7	209.3	5.7	7.2	205	215	215	225
OR 219,3X5,7	219.3	5.7	7.2	215	225	225	235
OR 229,3X5,7	229.3	5.7	7.2	225	235	235	245
OR 230X5,7	230	5.7	7.2	230	240	235	245
OR 239,3X5,7	239.3	5.7	7.2	235	245	245	255
OR 249,3X5,7	249.3	5.7	7.2	245	255	255	265

# OR

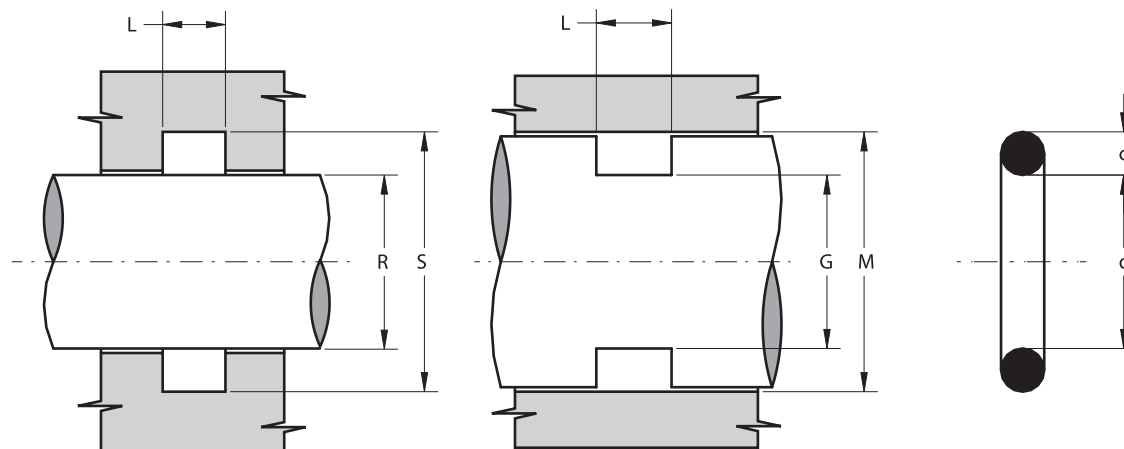

Cod. AS	d	c	L <sup>+0.2</sup>	R <sup>f7</sup>	S <sup>H9</sup>	G <sup>H9</sup>	M <sup>H8</sup>
OR 259,3X5,7	259.3	5.7	7.2	255	265	265	275
OR 269,3X5,7	269.3	5.7	7.2	265	275	275	285
OR 279,3X5,7	279.3	5.7	7.2	275	285	285	295
OR 289,3X5,7	289.3	5.7	7.2	285	295	295	305
OR 299,3X5,7	299.3	5.7	7.2	295	305	305	315
OR 319,3X5,7	319.3	5.7	7.2	315	325	325	335
OR 329,3X5,7	329.3	5.7	7.2	325	335	335	345
OR 339,3X5,7	339.3	5.7	7.2	335	345	345	355
OR 359,3X5,7	359.3	5.7	7.2	355	365	365	375
OR 379,3X5,7	379.3	5.7	7.2	375	385	385	395
OR 399,3X5,7	399.3	5.7	7.2	395	405	405	415
OR 419,3X5,7	419.3	5.7	7.2	415	425	425	435
OR 439,3X5,7	439.3	5.7	7.2	435	445	445	455
OR 499,3X5,7	499.3	5.7	7.2	495	505	505	515
OR 10X6	10	6	7.4	10	20.5	11.5	22
OR 11X6	11	6	7.4	11	21.5	12.5	23
OR 12X6	12	6	7.4	12	22.5	13.5	24
OR 13X6	13	6	7.4	13	23.5	14.5	25
OR 16X6	16	6	7.4	16	26.5	17.5	28
OR 18X6	18	6	7.4	18	28.5	19.5	30
OR 20X6	20	6	7.4	20	30.5	21.5	32
OR 21X6	21	6	7.4	21	31.5	22.5	33
OR 23X6	23	6	7.4	23	33.5	24.5	35

Cod. AS	d	c	L <sup>+0.2</sup>	R <sup>f7</sup>	S <sup>H9</sup>	G <sup>H9</sup>	M <sup>H8</sup>
OR 24X6	24	6	7.4	24	34.5	25.5	36
OR 25X6	25	6	7.4	25	35.5	26.5	37
OR 26X6	26	6	7.4	26	36.5	27.5	38
OR 27X6	27	6	7.4	27	37.5	28.5	39
OR 28X6	28	6	7.4	28	38.5	29.5	40
OR 30X6	30	6	7.4	30	40.5	31.5	42
OR 32X6	32	6	7.4	32	42.5	33.5	44
OR 34X6	34	6	7.4	34	44.5	35.5	46
OR 36X6	36	6	7.4	36	46.5	37.5	48
OR 38X6	38	6	7.4	38	48.5	39.5	50
OR 40X6	40	6	7.4	40	50.5	41.5	52
OR 41X6	41	6	7.4	41	51.5	42.5	53
OR 43X6	43	6	7.4	43	53.5	44.5	55
OR 45X6	45	6	7.4	45	55.5	46.5	57
OR 46X6	46	6	7.4	46	56.5	47.5	58
OR 47X6	47	6	7.4	47	57.5	48.5	59
OR 48X6	48	6	7.4	48	58.5	49.5	60
OR 50X6	50	6	7.4	50	60.5	51.5	62
OR 51X6	51	6	7.4	51	61.5	52.5	63
OR 52X6	52	6	7.4	52	62.5	53.5	64
OR 53X6	53	6	7.4	53	63.5	54.5	65
OR 55X6	55	6	7.4	55	65.5	56.5	67
OR 58X6	58	6	7.4	58	68.5	59.5	70
OR 59X6	59	6	7.4	59	69.5	60.5	71

Cod. AS	d	c	L <sup>+0.2</sup>	R <sup>f7</sup>	S <sup>H9</sup>	G <sup>H9</sup>	M <sup>H8</sup>
OR 59,5X6	59.5	6	7.4	59	69.5	61.5	72
OR 60X6	60	6	7.4	60	70.5	61.5	72
OR 63X6	63	6	7.4	63	73.5	64.5	75
OR 65X6	65	6	7.4	65	75.5	66.5	77
OR 68X6	68	6	7.4	68	78.5	69.5	80
OR 73X6	73	6	7.4	73	83.5	74.5	85
OR 74X6	74	6	7.4	74	84.5	75.5	86
OR 75X6	75	6	7.4	75	85.5	76.5	87
OR 76X6	76	6	7.4	76	86.5	77.5	88
OR 78X6	78	6	7.4	78	88.5	79.5	90
OR 79X6	79	6	7.4	79	89.5	80.5	91
OR 80X6	80	6	7.4	80	90.5	81.5	92
OR 84X6	84	6	7.4	84	94.5	85.5	96
OR 85X6	85	6	7.4	85	95.5	86.5	97
OR 86X6	86	6	7.4	86	96.5	87.5	98
OR 88X6	88	6	7.4	88	98.5	89.5	100
OR 90X6	90	6	7.4	90	100.5	91.5	102
OR 94X6	94	6	7.4	94	104.5	95.5	106
OR 95X6	95	6	7.4	95	105.5	96.5	107
OR 98X6	98	6	7.4	98	108.5	99.5	110
OR 100X6	100	6	7.4	100	110.5	101.5	112
OR 101X6	101	6	7.4	101	111.5	102.5	113
OR 105X6	105	6	7.4	105	115.5	106.5	117
OR 106X6	106	6	7.4	106	116.5	107.5	118



OR

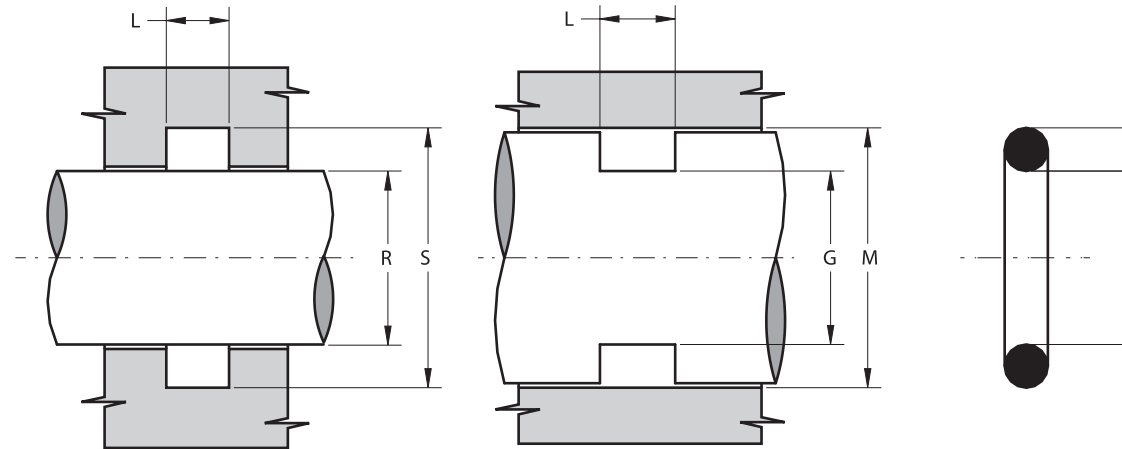

Cod. AS	d	c	L <sup>+0.2</sup>	R <sup>f7</sup>	S <sup>H9</sup>	G <sup>H9</sup>	M <sup>H8</sup>
OR 108X6	108	6	7.4	108	118.5	109.5	120
OR 110X6	110	6	7.4	110	120.5	111.5	122
OR 115X6	115	6	7.4	115	125.5	116.5	127
OR 118X6	118	6	7.4	118	128.5	119.5	130
OR 130X6	130	6	7.4	130	140.5	131.5	142
OR 135X6	135	6	7.4	135	145.5	136.5	147
OR 138X6	138	6	7.4	138	148.5	139.5	150
OR 138X6	138	6	7.4	138	148.5	139.5	150
OR 153X6	153	6	7.4	150	160.5	154.5	165
OR 158X6	158	6	7.4	155	165.5	159.5	170
OR 170X6	170	6	7.4	170	180.5	174.5	185
OR 180X6	180	6	7.4	180	190.5	184.5	195
OR 190X6	190	6	7.4	190	200.5	194.5	205
OR 220X6	220	6	7.4	220	230.5	224.5	235
OR 340X6	340	6	7.4	340	350.5	344.5	355
OR 380X6	380	6	7.4	380	390.5	384.5	395
OR 70X8	70	8	9.8	70	84	72	86

Cod. AS	d	c	L <sup>+0.2</sup>	R <sup>f7</sup>	S <sup>H9</sup>	G <sup>H9</sup>	M <sup>H8</sup>
OR 80X8	80	8	9.8	80	94	82	96
OR 136X8	136	8	9.8	136	150	138	152
OR 160X8	160	8	9.8	160	174	166	180
OR 305X8	305	8	9.8	305	319	311	325
OR 327X8	327	8	9.8	325	339	331	345
OR 450X8	450	8	9.8	450	464	456	470
OR 75X10	75	10	11.6	75	92.6	77.4	95
OR 85X10	85	10	11.6	85	102.6	87.4	105
OR 100X10	100	10	11.6	100	117.6	102.4	120
OR 150X10	150	10	11.6	150	167.6	152.4	170
OR 160X10	160	10	11.6	160	177.6	162.4	180
OR 164X10	164	10	11.6	160	177.6	167.4	185
OR 185X10	185	10	11.6	185	202.6	187.4	205
OR 255X10	255	10	11.6	255	272.6	257.4	275
OR 280X10	280	10	11.6	280	297.6	282.4	300
OR 623X10	623	10	11.6	620	637.6	627.4	645

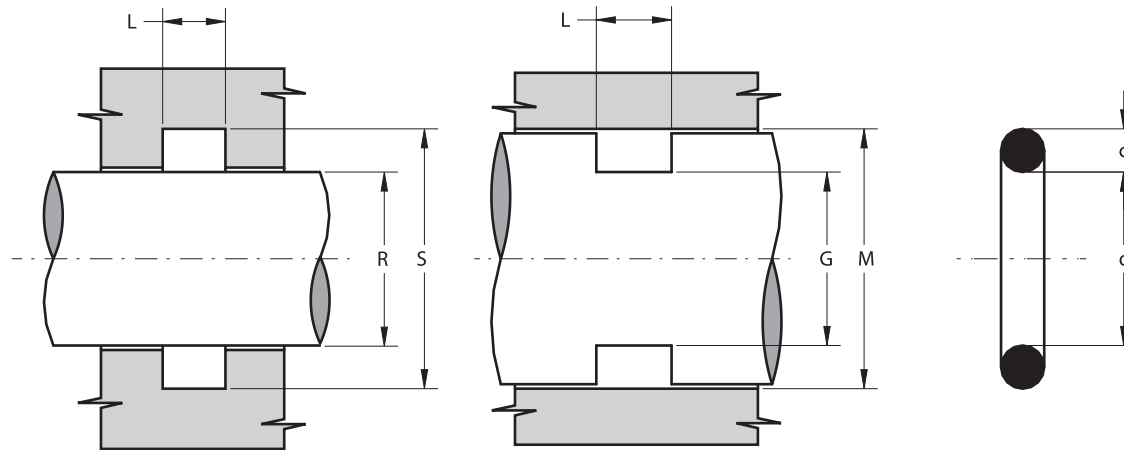

Other sizes not present in the above table can be provided, depending on the O-Ring chord "c", in according to the following scheme:

c	L			Radial Section (S-R)/2 or (M-G)/2	S	G
	without anti-extrusion ring	with 1 anti-extrusion ring	with 2 anti-extrusion rings			
1	1.4	-	-	0.7	R+1.4	M-1.4
1.5	2	-	-	1.2	R+2.4	M-2.4
1.6	2.1	3.1	4.1	1.25	R+2.5	M-2.5
1.78	2.5	4	5.5	1.55	R+3.1	M-3.1
2	2.7	4.1	5.5	1.65	R+3.3	M-3.3
2.4	3.2	4.6	6	2	R+4	M-4
2.5	3.3	4.7	6.1	2.1	R+4.2	M-4.2
2.62	3.5	5	6.5	2.25	R+4.5	M-4.5
3	4	5.4	6.8	2.5	R+5	M-5
3.53	4.5	6	7.5	3.1	R+6.2	M-6.2
4	5.2	6.9	8.6	3.5	R+7	M-7
4.5	5.8	7.5	9.2	3.9	R+7.8	M-7.8
5	6.6	8.3	10	4.35	R+8.7	M-8.7
5.34	7	9	10.5	4.7	R+9.4	M-9.4
5.7	7.2	8.9	10.6	5	R+10	M-10
6	7.4	9.1	10.8	5.25	R+10.5	M-10.5
6.99	9.5	12	14.5	6.1	R+12.2	M-12.2
8	9.8	12.3	14.8	7	R+14	M-14
10	11.6	14.1	16.6	8.8	R+17.6	M-17.6



# AP

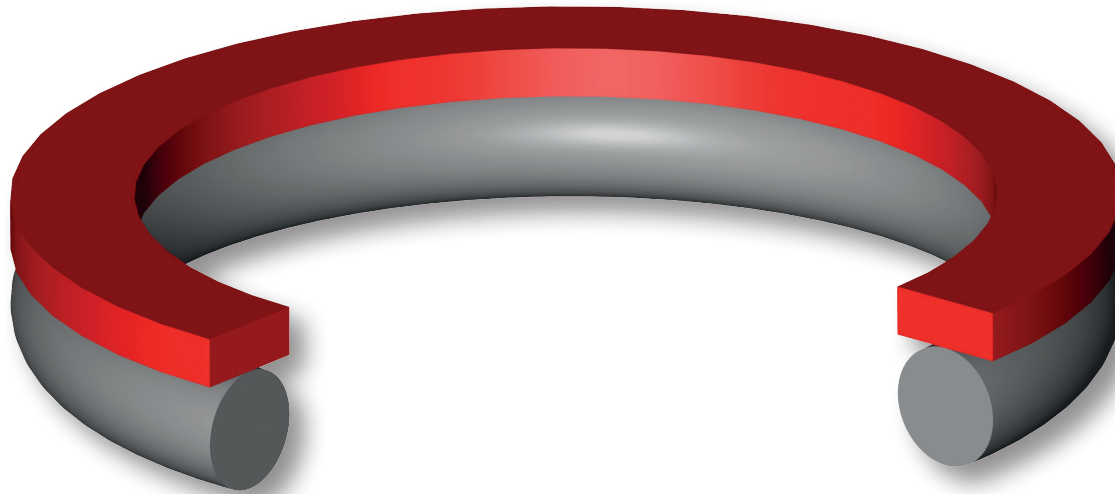

The function of ring type Aston Seals AP is to avoid the extrusion and damage of the O-Ring that normally occurs in the presence of large gaps or high pressure.

If pressure arises on only one side of the O-Ring, it will suffice to fit one antiextrusion ring on the unexposed side. Two backup rings are necessary if the pressure rises on both sides.

The AP ring hasn't a cut or spiral shape (typical of PTFE backup rings) that could help damage the O-Ring especially in the presence of high pressure.

Thanks to its elasticity, it can be installed very easily in a short time and without any auxiliaries.

The material used is a medium modulus

thermoplastic polyester resin, mainly used in the manufacturing of antiextrusion rings, that ensures an extra measure of performance and service life.

- Very high resistance against extrusion
- Uncut piece to avoid O-Ring damage
- Low cost solution
- Extended service life of sealing components
- Excellent wear-resistance
- No close tolerances are necessary
- Good temperature resistance
- Easy installation without expensive auxiliaries

### MATERIAL



<b>Type</b>	<b>Designation</b>	<b>Hardness</b>
Thermoplastic polyester resin	SEALITE 55	55 °ShD

### FIELD OF APPLICATION

<b>Pressure</b>	See table below
<b>Speed</b> ≤ 0.8 m/s	
<b>Temperature</b> -40°C ÷ +140°C (only for SEALITE element)	
<b>Fluids</b>	Hydraulic oils (mineral oil based) For other fluids contact our technical department

### MAX. PRESSURE [bar]

Gap [mm]	NBR 70 [bar]	NBR 90 [bar]	AP [bar]
0,05	190	330	500
0,10	130	270	400
0,15	110	230	350
0,20	100	210	300
0,25	90	190	270
0,30	80	170	240
0,35	75	160	220

NB: for the Gap calculation, it is necessary to consider the elastic deformation of metal elements under pressure loads.

### SURFACE ROUGHNESS

<b>Dynamic surface</b>	Ra ≤ 0.3 µm	Rt ≤ 2.5 µm
<b>Static surface</b>	Ra ≤ 1.6 µm	Rt ≤ 6.3 µm

Before assembly good cleanliness and lubrication are recommended.

The above data are maximum values, they may be maintained for short periods and can not be used at the same time simultaneously.

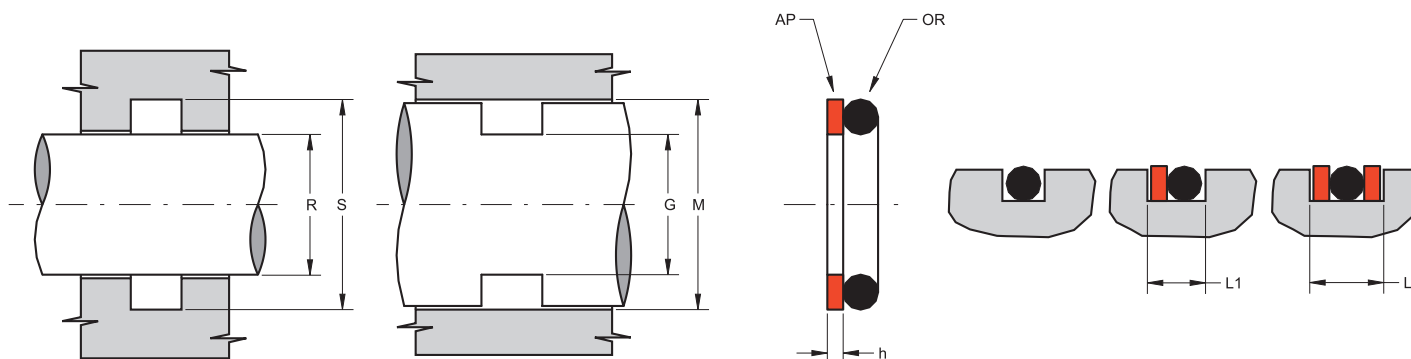

Part.	O-Ring	h	R <sup>f7</sup>	S <sup>H9</sup>	G <sup>H9</sup>	M <sup>H8</sup>	L1 <sup>+0.2</sup>	L2 <sup>+0.2</sup>
AP 010/610	OR 010 (6.07 x 1.78)	1.4	6	9.1	6.9	10	4	5.5
AP 010/610	OR 610 (6.75 x 1.78)	1.4	7	10.1	6.9	10	4	5.5
AP 011	OR 011 (7.65 x 1.78)	1.4	8	11.1	7.9	11	4	5.5
AP 012	OR 012 (9.25 x 1.78)	1.4	9	12.1	9.9	13	4	5.5
AP 013	OR 013 (10.82 x 1.78)	1.4	11	14.1	10.9	14	4	5.5
AP 014	OR 014 (12.42 x 1.78)	1.4	13	16.1	12.9	16	4	5.5
AP 015	OR 015 (14 x 1.78)	1.4	14	17.1	14.9	18	4	5.5
AP 016	OR 016 (15.6 x 1.78)	1.4	16	19.1	15.9	19	4	5.5
AP 017	OR 017 (17.17 x 1.78)	1.4	17	20.1	17.9	21	4	5.5
AP 018	OR 018 (18.77 x 1.78)	1.4	19	22.1	18.9	22	4	5.5
AP 019	OR 019 (20.35 x 1.78)	1.4	21	24.1	20.9	24	4	5.5
AP 020	OR 020 (21.95 x 1.78)	1.4	22	25.1	22.9	26	4	5.5
AP 022	OR 022 (25.12 x 1.78)	1.4	25	28.1	25.9	29	4	5.5
AP 023	OR 023 (26.7 x 1.78)	1.4	27	30.1	26.9	30	4	5.5
AP 024	OR 024 (28.3 x 1.78)	1.4	28	31.1	28.9	32	4	5.5
AP 025	OR 025 (29.87 x 1.78)	1.4	30	33.1	29.9	33	4	5.5
AP 026	OR 026 (31.47 x 1.78)	1.4	32	35.1	31.9	35	4	5.5
AP 029	OR 029 (37.82 x 1.78)	1.4	38	41.1	37.9	41	4	5.5
AP 032	OR 032 (47.35 x 1.78)	1.4	48	51.1	47.9	51	4	5.5
AP 109	OR 109 (7.6 x 2.62)	1.4	8	12.5	8.5	13	5	6.5
AP 110/613	OR 110 (9.19 x 2.62)	1.4	9	13.5	10.5	15	5	6.5
AP 110/613	OR 613 (9.92 x 2.62)	1.4	10	14.5	10.5	15	5	6.5
AP 111	OR 111 (10.77 x 2.62)	1.4	11	15.5	11.5	16	5	6.5
AP 614	OR 614 (11.91 x 2.62)	1.4	12	16.5	12.5	17	5	6.5

Part.	O-Ring	h	R <sup>f7</sup>	S <sup>H9</sup>	G <sup>H9</sup>	M <sup>H8</sup>	L1 <sup>+0.2</sup>	L2 <sup>+0.2</sup>
AP 112	OR 112 (12.37 x 2.62)	1.4	12.5	17	13.5	18	5	6.5
AP 113	OR 113 (13.94 x 2.62)	1.4	14	18.5	14.5	19	5	6.5
AP 616	OR 616 (15.08 x 2.62)	1.4	15	19.5	15.5	20	5	6.5
AP 114/809	OR 114 (15.54 x 2.62)	1.4	15.5	20	16.5	21	5	6.5
AP 114/809	OR 809 (15.88 x 2.62)	1.4	16	20.5	16.5	21	5	6.5
AP 115	OR 115 (17.12 x 2.62)	1.4	17	21.5	17.5	22	5	6.5
AP 617	OR 617 (17.86 x 2.62)	1.4	18	22.5	18.5	23	5	6.5
AP 116	OR 116 (18.72 x 2.62)	1.4	19	23.5	19.5	24	5	6.5
AP 117	OR 117 (20.29 x 2.62)	1.4	20	24.5	20.5	25	5	6.5
AP 812	OR 812 (20.63 x 2.62)	1.4	21	25.5	21.5	26	5	6.5
AP 118/813	OR 118 (21.89 x 2.62)	1.4	22	26.5	22.5	27	5	6.5
AP 118/813	OR 813 (22.22 x 2.62)	1.4	22	26.5	22.5	27	5	6.5
AP 119/814	OR 119 (23.47 x 2.62)	1.4	24	28.5	24.5	29	5	6.5
AP 119/814	OR 814 (23.81 x 2.62)	1.4	24	28.5	24.5	29	5	6.5
AP 120	OR 120 (25.07 x 2.62)	1.4	25	29.5	25.5	30	5	6.5
AP 121	OR 121 (26.64 x 2.62)	1.4	27	31.5	27.5	32	5	6.5
AP 122	OR 122 (28.24 x 2.62)	1.4	28	32.5	28.5	33	5	6.5
AP 123	OR 123 (29.82 x 2.62)	1.4	30	34.5	30.5	35	5	6.5
AP 124	OR 124 (31.42 x 2.62)	1.4	32	36.5	32.5	37	5	6.5
AP 125	OR 125 (32.99 x 2.62)	1.4	33	37.5	33.5	38	5	6.5
AP 126	OR 126 (34.6 x 2.62)	1.4	35	39.5	35.5	40	5	6.5
AP 127	OR 127 (36.14 x 2.62)	1.4	36	40.5	36.5	41	5	6.5
AP 128	OR 128 (37.77 x 2.62)	1.4	38	42.5	38.5	43	5	6.5
AP 129	OR 129 (39.34 x 2.62)	1.4	40	44.5	40.5	45	5	6.5

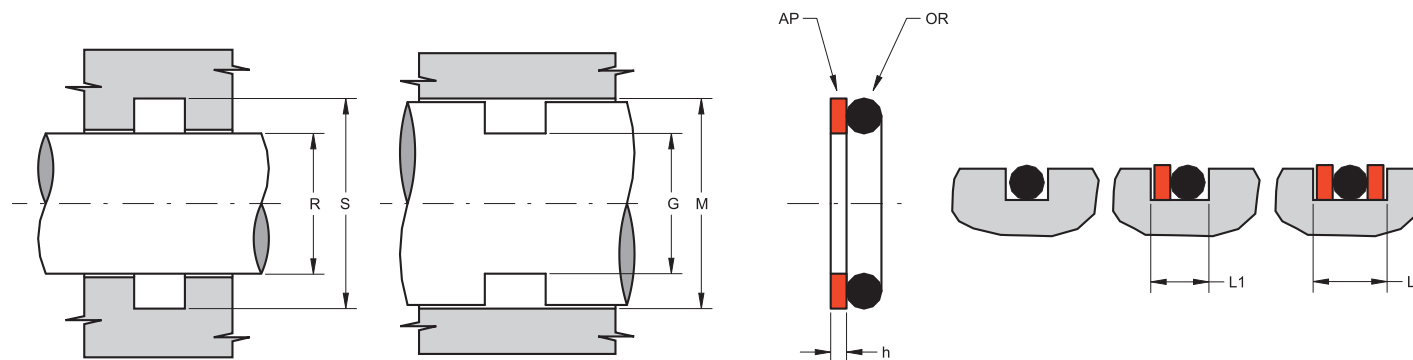

Part.	O-Ring	h	R <sup>f7</sup>	S <sup>H9</sup>	G <sup>h9</sup>	M <sup>H8</sup>	L1 <sup>+0.2</sup>	L2 <sup>+0.2</sup>
AP 130	OR 130 (40.95 x 2.62)	1.4	41	45.5	41.5	46	5	6.5
AP 131	OR 131 (42.52 x 2.62)	1.4	43	47.5	43.5	48	5	6.5
AP 132	OR 132 (44.12 x 2.62)	1.4	44	48.5	44.5	49	5	6.5
AP 133	OR 133 (45.69 x 2.62)	1.4	46	50.5	46.5	51	5	6.5
AP 134	OR 134 (47.3 x 2.62)	1.4	48	52.5	48.5	53	5	6.5
AP 135	OR 135 (48.9 x 2.62)	1.4	49	53.5	49.5	54	5	6.5
AP 136	OR 136 (50.47 x 2.62)	1.4	51	55.5	51.5	56	5	6.5
AP 137	OR 137 (52.07 x 2.62)	1.4	52	56.5	52.5	57	5	6.5
AP 138	OR 138 (53.65 x 2.62)	1.4	54	58.5	54.5	59	5	6.5
AP 139	OR 139 (55.25 x 2.62)	1.4	55	59.5	56.5	61	5	6.5
AP 140	OR 140 (56.82 x 2.62)	1.4	57	61.5	57.5	62	5	6.5
AP 141	OR 141 (58.42 x 2.62)	1.4	59	63.5	59.5	64	5	6.5
AP 142	OR 142 (60 x 2.62)	1.4	60	64.5	60.5	65	5	6.5
AP 143	OR 143 (61.6 x 2.62)	1.4	62	66.5	62.5	67	5	6.5
AP 144	OR 144 (63.17 x 2.62)	1.4	63	67.5	63.5	68	5	6.5
AP 145	OR 145 (64.77 x 2.62)	1.4	65	69.5	65.5	70	5	6.5
AP 146	OR 146 (66.35 x 2.62)	1.4	67	71.5	67.5	72	5	6.5
AP 147	OR 147 (67.95 x 2.62)	1.4	68	72.5	68.5	73	5	6.5
AP 148	OR 148 (69.52 x 2.62)	1.4	70	74.5	70.5	75	5	6.5
AP 149	OR 149 (71.12 x 2.62)	1.4	71	75.5	71.5	76	5	6.5
AP 150	OR 150 (72.69 x 2.62)	1.4	73	77.5	73.5	78	5	6.5
AP 151	OR 151 (75.87 x 2.62)	1.4	76	80.5	77.5	82	5	6.5
AP 152	OR 152 (82.22 x 2.62)	1.4	82	86.5	83.5	88	5	6.5
AP 153	OR 153 (88.57 x 2.62)	1.4	89	93.5	89.5	94	5	6.5

Part.	O-Ring	h	R <sup>f7</sup>	S <sup>H9</sup>	G <sup>h9</sup>	M <sup>H8</sup>	L1 <sup>+0.2</sup>	L2 <sup>+0.2</sup>
AP 154	OR 154 (94.92 x 2.62)	1.4	95	99.5	96.5	101	5	6.5
AP 157	OR 157 (113.97 x 2.62)	1.4	114	118.5	115.5	120	5	6.5
AP 210	OR 210 (18.64 x 3.53)	1.4	19	25.2	19.8	26	6	7.5
AP 211	OR 211 (20.22 x 3.53)	1.4	20	26.2	21.8	28	6	7.5
AP 212	OR 212 (21.82 x 3.53)	1.4	22	28.2	22.8	29	6	7.5
AP 213	OR 213 (23.4 x 3.53)	1.4	23	29.2	23.8	30	6	7.5
AP 214	OR 214 (24.99 x 3.53)	1.4	25	31.2	25.8	32	6	7.5
AP 618	OR 618 (25.8 x 3.53)	1.4	26	32.2	26.8	33	6	7.5
AP 215	OR 215 (26.58 x 3.53)	1.4	27	33.2	27.8	34	6	7.5
AP 216	OR 216 (28.17 x 3.53)	1.4	28	34.2	28.8	35	6	7.5
AP 217	OR 217 (29.75 x 3.53)	1.4	30	36.2	30.8	37	6	7.5
AP 218	OR 218 (31.34 x 3.53)	1.4	31	37.2	31.8	38	6	7.5
AP 219	OR 219 (32.92 x 3.53)	1.4	33	39.2	33.8	40	6	7.5
AP 220	OR 220 (34.52 x 3.53)	1.4	35	41.2	35.8	42	6	7.5
AP 221	OR 221 (36.09 x 3.53)	1.4	36	42.2	36.8	43	6	7.5
AP 222	OR 222 (37.69 x 3.53)	1.4	38	44.2	38.8	45	6	7.5
AP 824	OR 824 (39.69 x 3.53)	1.4	40	46.2	39.8	46	6	7.5
AP 223/825	OR 223 (40.87 x 3.53)	1.4	42	48.2	41.8	48	6	7.5
AP 223/825	OR 825 (41.28 x 3.53)	1.4	42	48.2	41.8	48	6	7.5
AP 826	OR 826 (42.86 x 3.53)	1.4	43	49.2	43.8	50	6	7.5
AP 224/827	OR 224 (44.04 x 3.53)	1.4	45	51.2	44.8	51	6	7.5
AP 224/827	OR 827 (44.45 x 3.53)	1.4	45	51.2	44.8	51	6	7.5
AP 828	OR 828 (46.04 x 3.53)	1.4	46	52.2	46.8	53	6	7.5
AP 225/829	OR 225 (47.22 x 3.53)	1.4	48	54.2	47.8	54	6	7.5

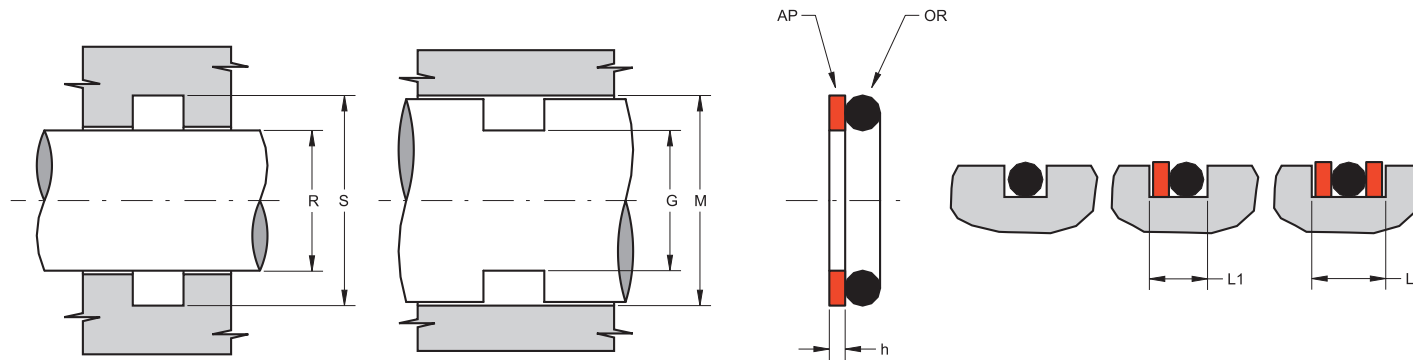

Part.	O-Ring	h	R <sup>f7</sup>	S <sup>H9</sup>	G <sup>H9</sup>	M <sup>H8</sup>	L1 <sup>+0.2</sup>	L2 <sup>+0.2</sup>
AP 225/829	OR 829 (47.63 x 3.53)	1.4	48	54.2	47.8	54	6	7.5
AP 830	OR 830 (49.21 x 3.53)	1.4	49	55.2	49.8	56	6	7.5
AP 226/831	OR 226 (50.39 x 3.53)	1.4	51	57.2	51.8	58	6	7.5
AP 226/831	OR 831 (50.8 x 3.53)	1.4	51	57.2	51.8	58	6	7.5
AP 832	OR 832 (52.39 x 3.53)	1.4	52	58.2	53.8	60	6	7.5
AP 227/833	OR 227 (53.57 x 3.53)	1.4	54	60.2	54.8	61	6	7.5
AP 227/833	OR 833 (53.98 x 3.53)	1.4	54	60.2	54.8	61	6	7.5
AP 834	OR 834 (55.56 x 3.53)	1.4	56	62.2	55.8	62	6	7.5
AP 228/835	OR 228 (56.74 x 3.53)	1.4	57	63.2	57.8	64	6	7.5
AP 228/835	OR 835 (57.15 x 3.53)	1.4	57	63.2	57.8	64	6	7.5
AP 836	OR 836 (58.74 x 3.53)	1.4	59	65.2	58.8	65	6	7.5
AP 229/837	OR 229 (59.92 x 3.53)	1.4	60	66.2	60.8	67	6	7.5
AP 229/837	OR 837 (60.33 x 3.53)	1.4	60	66.2	60.8	67	6	7.5
AP 838	OR 838 (61.91 x 3.53)	1.4	62	68.2	62.8	69	6	7.5
AP 230/839	OR 230 (63.09 x 3.53)	1.4	64	70.2	63.8	70	6	7.5
AP 840	OR 840 (65.09 x 3.53)	1.4	65	71.2	65.8	72	6	7.5
AP 231/841	OR 231 (66.27 x 3.53)	1.4	67	73.2	66.8	73	6	7.5
AP 231/841	OR 841 (66.68 x 3.53)	1.4	67	73.2	66.8	73	6	7.5
AP 842	OR 842 (68.26 x 3.53)	1.4	68	74.2	68.8	75	6	7.5
AP 232/843	OR 232 (69.44 x 3.53)	1.4	70	76.2	70.8	77	6	7.5
AP 232/843	OR 843 (69.85 x 3.53)	1.4	70	76.2	70.8	77	6	7.5
AP 844	OR 844 (71.44 x 3.53)	1.4	72	78.2	71.8	78	6	7.5
AP 233/845	OR 233 (72.62 x 3.53)	1.4	73	79.2	73.8	80	6	7.5
AP 233/845	OR 845 (73.03 x 3.53)	1.4	73	79.2	73.8	80	6	7.5

Part.	O-Ring	h	R <sup>f7</sup>	S <sup>H9</sup>	G <sup>H9</sup>	M <sup>H8</sup>	L1 <sup>+0.2</sup>	L2 <sup>+0.2</sup>
AP 846	OR 846 (74.61 x 3.53)	1.4	75	81.2	74.8	81	6	7.5
AP 234	OR 234 (75.79 x 3.53)	1.4	76	82.2	76.8	83	6	7.5
AP 235	OR 235 (78.97 x 3.53)	1.4	79	85.2	79.8	86	6	7.5
AP 236	OR 236 (82.14 x 3.53)	1.4	82	88.2	82.8	89	6	7.5
AP 237	OR 237 (85.32 x 3.53)	1.4	85	91.2	85.8	92	6	7.5
AP 238	OR 238 (88.49 x 3.53)	1.4	89	95.2	88.8	95	6	7.5
AP 239	OR 239 (91.67 x 3.53)	1.4	92	98.2	92.8	99	6	7.5
AP 240	OR 240 (94.84 x 3.53)	1.4	95	101.2	95.8	102	6	7.5
AP 241	OR 241 (98.02 x 3.53)	1.4	98	104.2	98.8	105	6	7.5
AP 242	OR 242 (101.19 x 3.53)	1.4	101	107.2	101.8	108	6	7.5
AP 243	OR 243 (104.37 x 3.53)	1.4	105	111.2	104.8	111	6	7.5
AP 244	OR 244 (107.54 x 3.53)	1.4	108	114.2	107.8	114	6	7.5
AP 245	OR 245 (110.72 x 3.53)	1.4	111	117.2	111.8	118	6	7.5
AP 246	OR 246 (113.89 x 3.53)	1.4	114	120.2	114.8	121	6	7.5
AP 247	OR 247 (117.07 x 3.53)	1.4	117	123.2	117.8	124	6	7.5
AP 248	OR 248 (120.24 x 3.53)	1.4	120	126.2	120.8	127	6	7.5
AP 249	OR 249 (123.42 x 3.53)	1.4	123	129.2	123.8	130	6	7.5
AP 250	OR 250 (126.59 x 3.53)	1.4	127	133.2	126.8	133	6	7.5
AP 251	OR 251 (129.77 x 3.53)	1.4	130	136.2	129.8	136	6	7.5
AP 252	OR 252 (132.94 x 3.53)	1.4	133	139.2	133.8	140	6	7.5
AP 253	OR 253 (136.12 x 3.53)	1.4	136	142.2	136.8	143	6	7.5
AP 254	OR 254 (139.29 x 3.53)	1.4	140	146.2	139.8	146	6	7.5
AP 255	OR 255 (142.47 x 3.53)	1.4	143	149.2	142.8	149	6	7.5
AP 256	OR 256 (145.64 x 3.53)	1.4	146	152.2	145.8	152	6	7.5

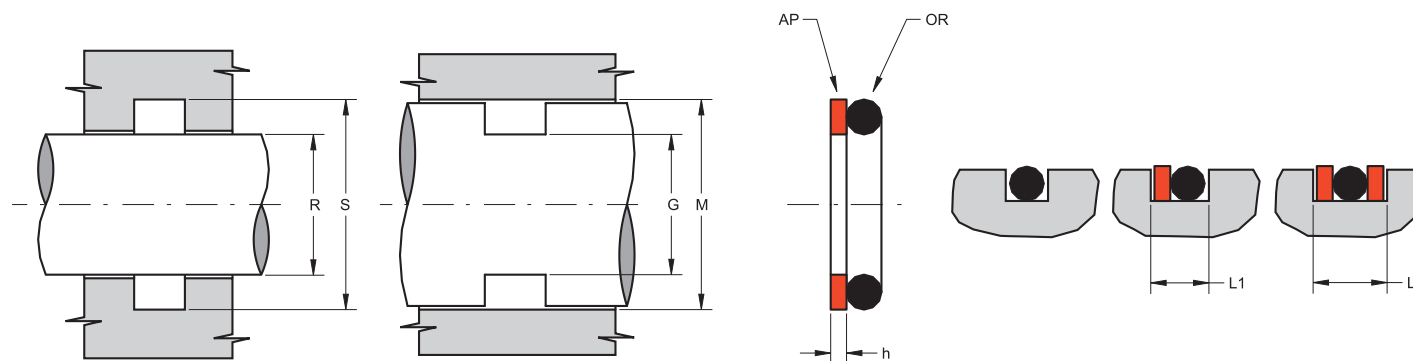

Part.	O-Ring	h	R <sup>f7</sup>	S <sup>H9</sup>	G <sup>h9</sup>	M <sup>H8</sup>	L1 <sup>+0.2</sup>	L2 <sup>+0.2</sup>
AP 257	OR 257 (148.82 x 3.53)	1.4	149	155.2	148.8	155	6	7.5
AP 258	OR 258 (151.99 x 3.53)	1.4	152	158.2	152.8	159	6	7.5
AP 264	OR 264 (190.09 x 3.53)	1.4	190	196.2	190.8	197	6	7.5
AP 325	OR 325 (37.47 x 5.34)	1.7	38	47.4	38.6	48	9	10.5
AP 326	OR 326 (40.65 x 5.34)	1.7	41	50.4	42.6	52	9	10.5
AP 327	OR 327 (43.82 x 5.34)	1.7	44	53.4	45.6	55	9	10.5
AP 328	OR 328 (47 x 5.34)	1.7	47	56.4	48.6	58	9	10.5
AP 329	OR 329 (50.16 x 5.34)	1.7	50	59.4	51.6	61	9	10.5
AP 330	OR 330 (53.34 x 5.34)	1.7	53	62.4	54.6	64	9	10.5
AP 331	OR 331 (56.52 x 5.34)	1.7	57	66.4	58.6	68	9	10.5
AP 332	OR 332 (59.69 x 5.34)	1.7	60	69.4	60.6	70	9	10.5
AP 333	OR 333 (62.87 x 5.34)	1.7	63	72.4	63.6	73	9	10.5
AP 334	OR 334 (66.04 x 5.34)	1.7	66	75.4	67.6	77	9	10.5
AP 335	OR 335 (69.22 x 5.34)	1.7	69	78.4	70.6	80	9	10.5
AP 336	OR 336 (72.39 x 5.34)	1.7	73	82.4	73.6	83	9	10.5
AP 619	OR 619 (74.63 x 5.34)	1.7	75	84.4	75.6	85	9	10.5
AP 337	OR 337 (75.57 x 5.34)	1.7	76	85.4	76.6	86	9	10.5
AP 338	OR 338 (78.74 x 5.34)	1.7	79	88.4	80.6	90	9	10.5
AP 620	OR 620 (79.77 x 5.34)	1.7	80	89.4	81.6	91	9	10.5
AP 339	OR 339 (81.92 x 5.34)	1.7	82	91.4	82.6	92	9	10.5
AP 340	OR 340 (85.09 x 5.34)	1.7	85	94.4	85.6	95	9	10.5
AP 341	OR 341 (88.27 x 5.34)	1.7	88	97.4	88.6	98	9	10.5
AP 621	OR 621 (89.69 x 5.34)	1.7	90	99.4	90.6	100	9	10.5
AP 342	OR 342 (91.44 x 5.34)	1.7	92	101.4	92.6	102	9	10.5

Part.	O-Ring	h	R <sup>f7</sup>	S <sup>H9</sup>	G <sup>h9</sup>	M <sup>H8</sup>	L1 <sup>+0.2</sup>	L2 <sup>+0.2</sup>
AP 343	OR 343 (94.62 x 5.34)	1.7	95	104.4	95.6	105	9	10.5
AP 344	OR 344 (97.79 x 5.34)	1.7	98	107.4	98.6	108	9	10.5
AP 622	OR 622 (100 x 5.34)	1.7	100	109.4	100.6	110	9	10.5
AP 345	OR 345 (100.97 x 5.34)	1.7	101	110.4	101.6	111	9	10.5
AP 346	OR 346 (104.14 x 5.34)	1.7	104	113.4	105.6	115	9	10.5
AP 347	OR 347 (107.32 x 5.34)	1.7	107	116.4	108.6	118	9	10.5
AP 623	OR 623 (109.5 x 5.34)	1.7	110	119.4	110.6	120	9	10.5
AP 348	OR 348 (110.5 x 5.34)	1.7	111	120.4	111.6	121	9	10.5
AP 349	OR 349 (113.67 x 5.34)	1.7	114	123.4	115.6	125	9	10.5
AP 350/860	OR 350 (116.84 x 5.34)	1.7	117	126.4	118.6	128	9	10.5
AP 350/860	OR 860 (117.5 x 5.34)	1.7	118	127.4	118.6	128	9	10.5
AP 351/861	OR 351 (120.02 x 5.34)	1.7	121	130.4	122.6	132	9	10.5
AP 351/861	OR 861 (120.7 x 5.34)	1.7	121	130.4	122.6	132	9	10.5
AP 862	OR 862 (123.8 x 5.34)	1.7	124	133.4	125.6	135	9	10.5
AP 353/863	OR 353 (126.37 x 5.34)	1.7	127	136.4	127.6	137	9	10.5
AP 353/863	OR 863 (127 x 5.34)	1.7	127	136.4	127.6	137	9	10.5
AP 354/864	OR 354 (129.54 x 5.34)	1.7	130	139.4	130.6	140	9	10.5
AP 354/864	OR 864 (130.2 x 5.34)	1.7	130	139.4	130.6	140	9	10.5
AP 865	OR 865 (133.4 x 5.34)	1.7	134	143.4	135.6	145	9	10.5
AP 356/866	OR 356 (135.9 x 5.34)	1.7	137	146.4	137.6	147	9	10.5
AP 356/866	OR 866 (136.5 x 5.34)	1.7	137	146.4	137.6	147	9	10.5
AP 357/867	OR 357 (139.07 x 5.34)	1.7	140	149.4	140.6	150	9	10.5
AP 357/867	OR 867 (139.7 x 5.34)	1.7	140	149.4	140.6	150	9	10.5
AP 358/868	OR 358 (142.24 x 5.34)	1.7	143	152.4	143.6	153	9	10.5



AP

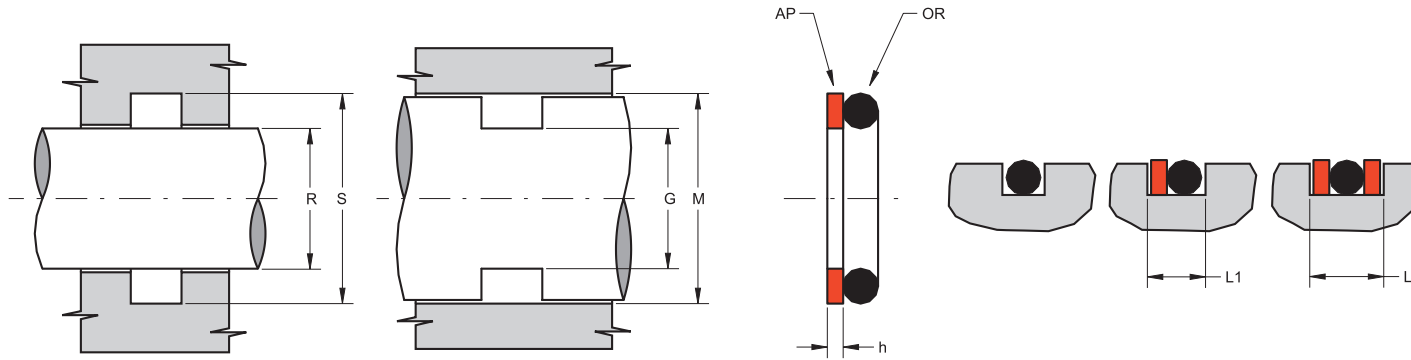

Part.	O-Ring	h	R <sup>f7</sup>	S <sup>H9</sup>	G <sup>h9</sup>	M <sup>H8</sup>	L1 <sup>+0.2</sup>	L2 <sup>+0.2</sup>
<b>AP 358/868</b>	OR 868 (142.9 x 5.34)	1.7	143	152.4	143.6	153	9	10.5
<b>AP 360/870</b>	OR 360 (148.6 x 5.34)	1.7	150	159.4	150.6	160	9	10.5
<b>AP 360/870</b>	OR 870 (149.2 x 5.34)	1.7	150	159.4	150.6	160	9	10.5
<b>AP 361</b>	OR 361 (151.77 x 5.34)	1.7	152	161.4	153.6	163	9	10.5
<b>AP 362</b>	OR 362 (158.12 x 5.34)	1.7	158	167.4	159.6	169	9	10.5
<b>AP 363</b>	OR 363 (164.47 x 5.34)	1.7	165	174.4	165.6	175	9	10.5
<b>AP 364</b>	OR 364 (170.82 x 5.34)	1.7	171	180.4	172.6	182	9	10.5
<b>AP 365</b>	OR 365 (177.17 x 5.34)	1.7	178	187.4	178.6	188	9	10.5
<b>AP 367</b>	OR 367 (189.87 x 5.34)	1.7	190	199.4	190.6	200	9	10.5
<b>AP 370</b>	OR 370 (208.92 x 5.34)	1.7	209	218.4	210.6	220	9	10.5
<b>AP 425</b>	OR 425 (113.67 x 6.99)	2.5	114	126.2	114.8	127	12	14.5
<b>AP 426</b>	OR 426 (116.84 x 6.99)	2.5	117	129.2	117.8	130	12	14.5
<b>AP 428</b>	OR 428 (123.2 x 6.99)	2.5	123	135.2	124.8	137	12	14.5
<b>AP 429</b>	OR 429 (126.37 x 6.99)	2.5	126	138.2	127.8	140	12	14.5
<b>AP 431</b>	OR 431 (132.72 x 6.99)	2.5	133	145.2	133.8	146	12	14.5
<b>AP 432</b>	OR 432 (135.9 x 6.99)	2.5	136	148.2	137.8	150	12	14.5
<b>AP 433</b>	OR 433 (139.07 x 6.99)	2.5	139	151.2	140.8	153	12	14.5
<b>AP 435</b>	OR 435 (145.42 x 6.99)	2.5	145	157.2	147.8	160	12	14.5
<b>AP 872</b>	OR 872 (155.6 x 6.99)	2.5	156	168.2	157.8	170	12	14.5
<b>AP 628</b>	OR 628 (166.7 x 6.99)	2.5	167	179.2	167.8	180	12	14.5
<b>AP 442</b>	OR 442 (183.52 x 6.99)	2.5	184	196.2	184.8	197	12	14.5
<b>AP 443</b>	OR 443 (189.87 x 6.99)	2.5	190	202.2	190.8	203	12	14.5
<b>AP 444</b>	OR 444 (196.22 x 6.99)	2.5	196	208.2	197.8	210	12	14.5

# AM



## MATERIAL

	<b>Type</b>	<b>Designation</b>	<b>Hardness</b>
	Thermoplastic polyester resin	SEALITE 55	55 °ShD

## FIELD OF APPLICATION

<b>Pressure</b>	See table below
<b>Speed</b> ≤ 0.8 m/s	
<b>Temperature</b> -40°C ÷ +140°C (only for SEALITE element)	
<b>Fluids</b>	Hydraulic oils (mineral oil based) For other fluids contact our technical department

## MAX. PRESSURE [bar]

Gap [mm]	NBR 70 [bar]	NBR 90 [bar]	AM [bar]
0,05	190	330	500
0,10	130	270	400
0,15	110	230	350
0,20	100	210	300
0,25	90	190	270
0,30	80	170	240
0,35	75	160	220

NB: for the Gap calculation, it is necessary to consider the elastic deformation of metal elements under pressure loads.

## SURFACE ROUGHNESS

<b>Dynamic surface</b>	Ra ≤ 0.3 µm	Rt ≤ 2.5 µm
<b>Static surface</b>	Ra ≤ 1.6 µm	Rt ≤ 6.3 µm

Before assembly good cleanliness and lubrication are recommended.  
The above data are maximum values, they may be maintained for short periods and can not be used at the same time simultaneously.

The function of ring type Aston Seals AM is to avoid the extrusion and damage of the O-Ring that normally occurs in the presence of large gaps or high pressure.

If pressure arises on only one side of the O-Ring, it will suffice to fit one antiextrusion ring on the unexposed side. Two backup rings are necessary if the pressure rises on both sides.

The AM ring hasn't a cut or spiral shape (typical of PTFE backup rings) that could help damage the O-Ring especially in the presence of high pressure.

Thanks to its elasticity, it can be installed very easily in a short time and without any auxiliaries.

The material used is a medium modulus thermoplastic polyester resin, mainly used in

the manufacturing of antiextrusion rings, that ensures an extra measure of performance and service life in application where properties such as abrasion resistance and tear strength are critical.

- Very high resistance against extrusion
- Uncut piece to avoid O-Ring damage
- Low cost solution
- Extended service life of sealing components
- Excellent wear-resistance
- No close tolerances are necessary
- Easy installation without expensive auxiliaries
- Good temperature resistance
- Easy installation without expensive auxiliaries

# AM

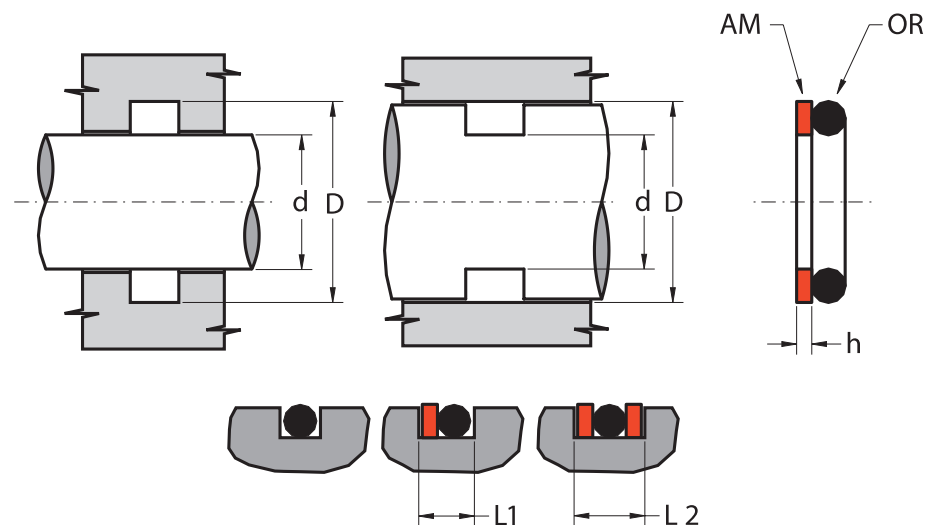

Part.	O-Ring	d <sup>f7</sup>	D <sup>H9</sup>	h	L1 <sup>+0.2</sup>	L2 <sup>+0.2</sup>
AM 3.8 6.5 1	4.1 x 1.6	3.8	6.5	1.0	3.1	4.1
AM 6 10.5 0.8	5.23 x 2.62	6	10.5	0.8	4.4	5.3
AM 10 14 1.3	9.3 x 2.4	10	14	1.3	4.5	5.8
AM 12 16 1.3	11.3 x 2.4	12	16	1.3	4.5	5.8
AM 16 20 1.3	15.3 x 2.4	16	20	1.3	4.5	5.8
AM 17 21 1.3	16.3 x 2.4	17	21	1.3	4.5	5.8
AM 20 25 1.3	19.2 x 3	20	25	1.3	5.3	6.6
AM 25 30 1.3	24.2 x 3	25	30	1.3	5.3	6.6
AM 25 32 1.3	24 x 4	25	32	1.3	6.7	8.2
AM 27 32 1.3	26.2 x 3	27	32	1.3	5.3	6.6
AM 29.3 35 1.4	28.17 x 3.53	29.3	35	1.4	6.0	7.5
AM 30 35 1.3	29.2 x 3	30	35	1.3	5.3	6.6
AM 33 38 1.3	32.2 x 3	33	38	1.3	5.3	6.6
AM 35 40 1.3	34.2 x 3	35	40	1.3	5.3	6.6
AM 36 41 1.75	34.5 x 3	36	41	1.75	5.75	7.5
AM 40 45 1.3	39.2 x 3	40	45	1.3	5.3	6.6
AM 42.5 50 2	42 x 4.5	42.5	50	2.0	7.8	9.8
AM 45 50 1.3	44.2 x 3	45	50	1.3	5.3	6.6
AM 45 55 1.7	45.3 x 5.7	45	55	1.7	9.5	11.5
AM 50 55 1.3	49.5 x 3	50	55	1.3	5.3	6.6
AM 50 56.2 1.4	49.21 x 3.53	50	56.2	1.4	6.0	7.5
AM 50 60 1.7	49.2 x 5.7	50	60	1.7	9.5	11.5
AM 53 63 1.7	52.3 x 5.7	53	63	1.7	9.5	11.5
AM 54 59 1.4	53.1 x 3	54	59	1.4	5.4	6.8

Part.	O-Ring	d <sup>f7</sup>	D <sup>H9</sup>	h	L1 <sup>+0.2</sup>	L2 <sup>+0.2</sup>
AM 55 60 1.3	54.5 x 3	55	60	1.3	5.3	6.6
AM 55 65 1.7	54.2 x 5.7	55	65	1.7	9.5	11.5
AM 56.5 61 1.4	55.25 x 2.62	56.5	61	1.4	5.0	6.4
AM 58 63 1.3	57.0 x 3	58	63	1.3	5.3	6.6
AM 60 65 1.3	59.5 x 3	60	65	1.3	5.3	6.6
AM 60 67 1.5	59 x 4	60	67	1.5	6.9	8.4
AM 60 70 1.7	59.2 x 5.7	60	70	1.7	9.5	11.5
AM 64 70 1.4	63.5 x 3.53	64	70	1.4	6.0	7.5
AM 65 70 1.3	64.5 x 3	65	70	1.3	5.3	6.6
AM 65 75 1.7	64.2 x 5.7	65	75	1.7	9.5	11.5
AM 66 71 1.5	64.5 x 3	66	71	1.5	5.5	7.0
AM 66.4 72 1.4	65.09 x 3.53	66.4	72	1.4	6.0	7.4
AM 69 75 1.5	68.26 x 3.53	69	75	1.5	6.1	7.6
AM 70 75 1.3	69.5 x 3	70	75	1.3	5.3	6.6
AM 70 77 1.5	69 x 4	70	77	1.5	6.9	8.4
AM 70 80 1.7	69.2 x 5.7	70	80	1.7	9.5	11.5
AM 74 80 1.5	72.62 x 3.53	74	80	1.5	6.1	7.6
AM 74.1 81 1.5	74 x 4	74.1	81	1.5	6.8	8.3
AM 75 80 1.3	74.6 x 3	75	80	1.3	5.3	6.6
AM 75 85 1.7	74.2 x 5.7	75	85	1.7	9.5	11.5
AM 79.4 85 1.3	78.97 x 3.53	79.4	85	1.3	6.0	7.5
AM 80 85 1.3	79.5 x 3	80	85	1.3	5.3	6.6
AM 80 87 1.5	79 x 4	80	87	1.5	6.9	8.4
AM 80 90 1.7	79.2 x 5.7	80	90	1.7	9.5	11.5

Part.	O-Ring	d <sup>f7</sup>	D <sup>H9</sup>	h	L1 <sup>+0.2</sup>	L2 <sup>+0.2</sup>
AM 83 90 1.5	83 x 4	83	90	1.5	6.8	8.3
AM 84 90 1.4	82.14 x 3.53	84	90	1.4	6.0	7.5
AM 85 90 1.3	84.5 x 3	85	90	1.3	5.3	6.6
AM 85 95 1.7	84.1 x 5.7	85	95	1.7	9.5	11.5
AM 89.4 100 2.5	88 x 6	89.4	100	2.5	10.7	13.2
AM 90 95 1.3	89.5 x 3	90	95	1.3	5.3	6.6
AM 90 100 1.7	89.1 x 5.7	90	100	1.7	9.5	11.5
AM 93.5 100 1.4	91.67 x 3.53	93.5	100	1.4	6.0	7.4
AM 94.5 101 1.5	94.84 x 3.53	94.5	101	1.5	6.1	7.6
AM 95 100 1.3	94.5 x 3	95	100	1.3	5.3	6.6
AM 95 105 1.7	94.1 x 5.7	95	105	1.7	9.5	11.5
AM 100 105 1.3	99.5 x 3	100	105	1.3	5.3	6.6
AM 100 110 1.7	99.1 x 5.7	100	110	1.7	9.5	11.5
AM 105 110 1.3	104.5 x 3	105	110	1.3	5.3	6.6
AM 105 115 1.7	104.1 x 5.7	105	115	1.7	9.5	11.5
AM 110 115 1.3	109.5 x 3	110	115	1.3	5.3	6.6
AM 110 120 1.7	109.1 x 5.7	110	120	1.7	9.5	11.5
AM 115 120 1.3	114.5 x 3	115	120	1.3	5.3	6.6
AM 115 125 1.7	114.3 x 5.7	115	125	1.7	9.5	11.5
AM 119 126 1.5	118 x 4	119	126	1.5	6.9	8.4
AM 120 125 1.3	119.5 x 3	120	125	1.3	5.3	6.6
AM 120 130 1.7	119.3 x 5.7	120	130	1.7	9.5	11.5
AM 125 130 1.3	124.5 x 3	125	130	1.3	5.3	6.6
AM 125 135 1.7	124.3 x 5.7	125	135	1.7	9.5	11.5

AM

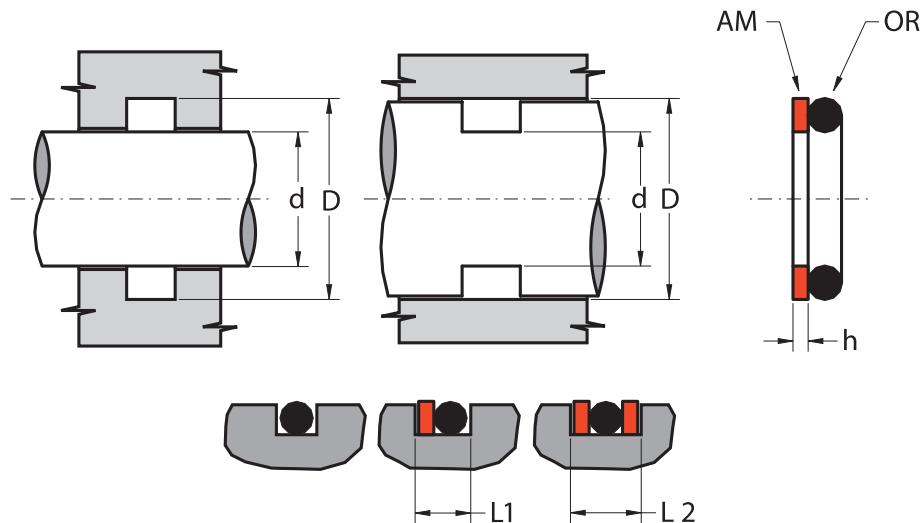

Part.	O-Ring	d <sup>f7</sup>	D <sup>H9</sup>	h	L1 <sup>+0.2</sup>	L2 <sup>+0.2</sup>
<b>AM 130 140 1.7</b>	129.3 x 5.7	130	140	1.7	9.5	11.5
<b>AM 135 145 1.7</b>	134.3 x 5.7	135	145	1.7	9.5	11.5
<b>AM 140 150 1.7</b>	139.3 x 5.7	140	150	1.7	9.5	11.5
<b>AM 142 151 1.8</b>	140 x 5.3	142	151	1.8	9.0	10.8
<b>AM 145 155 1.7</b>	144.3 x 5.7	145	155	1.7	9.5	11.5
<b>AM 150 160 1.7</b>	149.3 x 5.7	150	160	1.7	9.5	11.5
<b>AM 152 161 1.8</b>	150 x 5.3	152	161	1.8	9.0	10.8
<b>AM 154 166 3</b>	155.6 x 6.99	154	166	3.0	12.5	15.5



# BRC

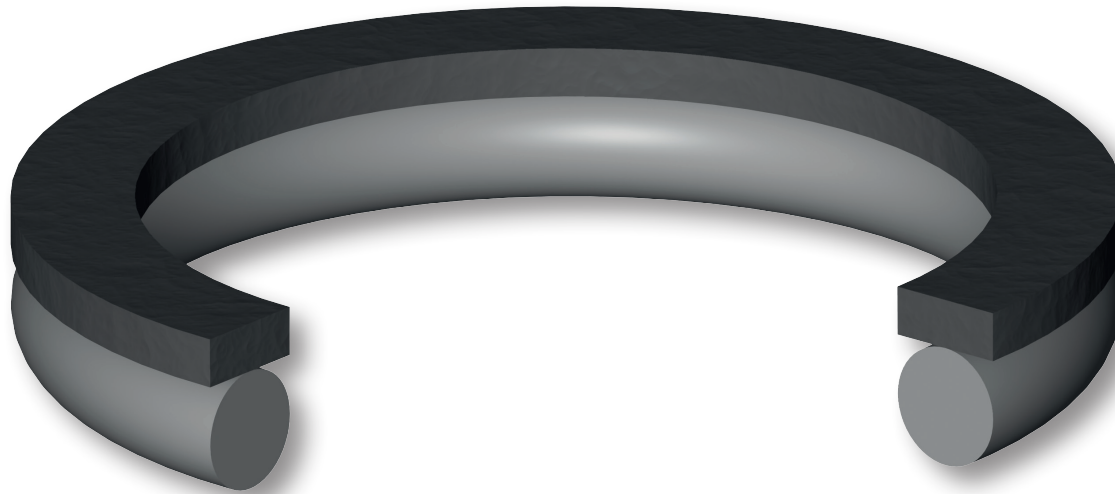

The function of ring type Aston Seals BRC is to avoid the extrusion and damage of the O-Ring that normally occurs in the presence of large gaps or high pressure.

If pressure arises on only one side of the O-Ring, it will suffice to fit one antiextrusion ring on the unexposed side. Two backup rings are necessary if the pressure rises on both sides.

The BRC ring hasn't a cut or spiral shape that could help damage the O-Ring especially in the presence of high pressure.

The material used ensures an high compatibility with nearly all media due to the chemical resistance which exceeds that of all

other thermoplastics and elastomers.

- Very high resistance against extrusion
- Uncut piece to avoid O-Ring damage
- Extended service life of sealing components
- High compatibility with nearly all fluids
- Excellent wear-resistance
- High temperature resistance

## MATERIAL



Type Polytetrafluoroethylene PTFE  
Designation SEALFLON

## CODING

"BRC xxx" where "xxx" is the same code of O-Ring

## FIELD OF APPLICATION

### Pressure

≤ 500 bar  
with a max. gap 0.3 mm (\*)

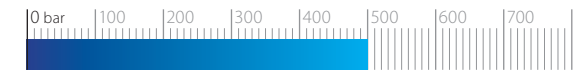

### Speed

≤ 2m/s



### Temperature

-200°C ÷ +200°C  
(only for PTFE element)

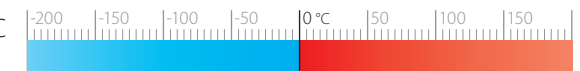

### Fluids

High compatibility with nearly all fluids  
(only for PTFE element)

(\*) for the Gap calculation, it is necessary to consider the elastic deformation of metal elements under pressure loads

## GROOVE DIMENSIONS [mm]

Section OR	h	L	L1	L2
1.78	1.4	2.5	4	5.5
2.62	1.4	3.5	5	6.5
3.53	1.4	4.5	6	7.5
5.34	1.7	7.0	9	10.5
6.99	2.5	9.5	12	14.5

Internal and external diameters are the same used for O-Rings

## SURFACE ROUGHNESS

Dynamic surface	Ra ≤ 0.3 μm	Rt ≤ 2.5 μm
Static surface	Ra ≤ 1.6 μm	Rt ≤ 6.3 μm

Before assembly good cleanliness and lubrication are recommended.

The above data are maximum values, they may be maintained for short periods and can not be used at the same time simultaneously.

# BRC

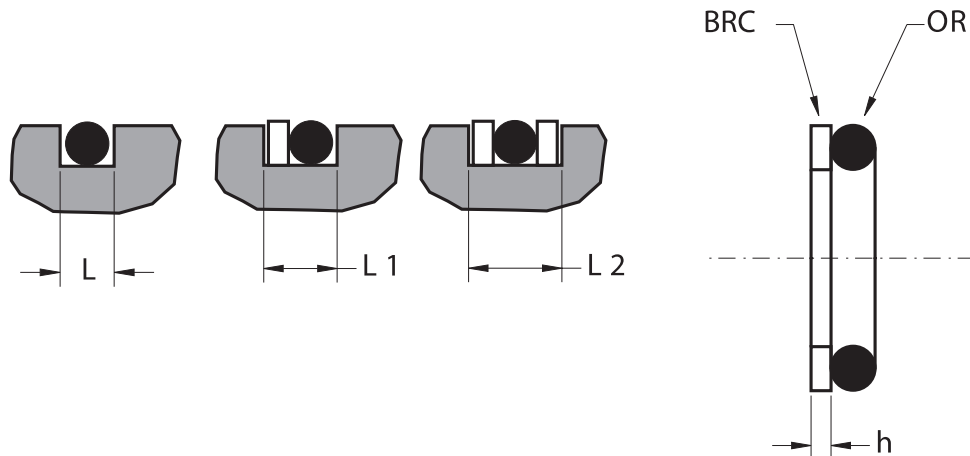

# BRT

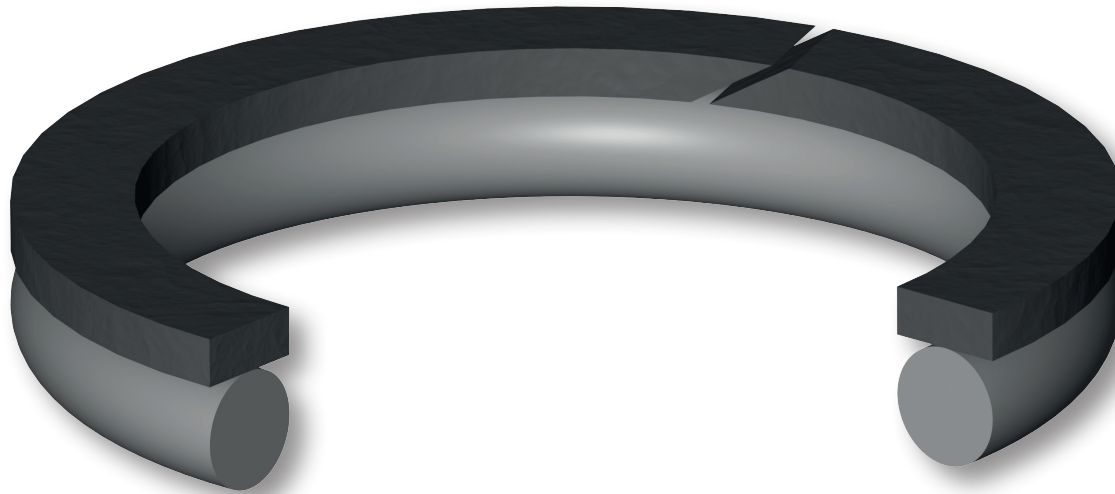

The function of ring type Aston Seals BRT is to avoid the extrusion and damage of the O-Ring that normally occurs in the presence of large gaps or high pressure.

If pressure arises on only one side of the O-Ring, it will suffice to fit one antiextrusion ring on the unexposed side. Two backup rings are necessary if the pressure rises on both sides.

The BRT ring is cut at an angle of 30°, so protection of the O-ring is ensured by the cut. Thanks to this, it can be installed very easily in a short time and without any auxiliaries.

The material used ensures a high compatibility with nearly all media due to the chemical

resistance which exceeds that of all other thermoplastics and elastomers.

- Very high resistance against extrusion
- Extended service life of sealing components
- High compatibility with nearly all fluids
- Excellent wear-resistance
- High temperature resistance
- Easy installation without expensive auxiliaries

## MATERIAL



Type Polytetrafluoroethylene PTFE  
Designation SEALFLON

## CODING

“BRT xxx” where “xxx” is the same code of O-Ring

## FIELD OF APPLICATION

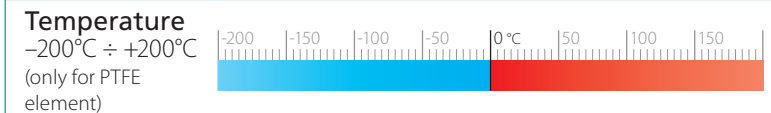
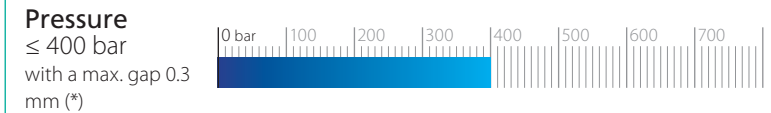

**Fluids** High compatibility with nearly all fluids  
(only for PTFE element)

(\*) for the Gap calculation, it is necessary to consider the elastic deformation of metal elements under pressure loads

## GROOVE DIMENSIONS [mm]

Section OR	h	L	L1	L2
1.78	1.4	2.5	4	5.5
2.62	1.4	3.5	5	6.5
3.53	1.4	4.5	6	7.5
5.34	1.7	7.0	9	10.5
6.99	2.5	9.5	12	14.5

Internal and external diameters are the same used for O-Rings

## SURFACE ROUGHNESS

<b>Dynamic surface</b>	Ra ≤ 0.3 μm	Rt ≤ 2.5 μm
<b>Static surface</b>	Ra ≤ 1.6 μm	Rt ≤ 6.3 μm

Before assembly good cleanliness and lubrication are recommended.

The above data are maximum values, they may be maintained for short periods and can not be used at the same time simultaneously.



# BRT

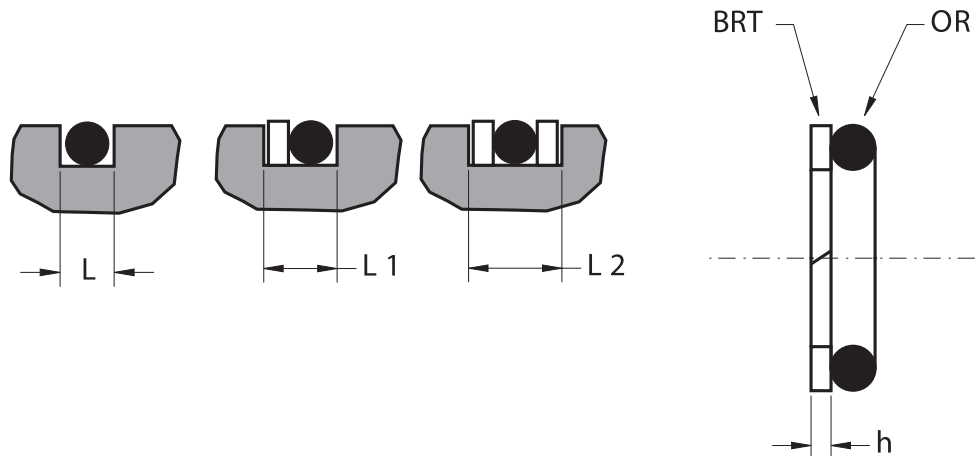

# BRA



The function of ring type Aston Seals BRA is to avoid the extrusion and damage of the O-Ring that normally occurs in the presence of large gaps or high pressure.

If pressure arises on only one side of the O-Ring, it will suffice to fit one antiextrusion ring on the unexposed side. Two backup rings are necessary if the pressure rises on both sides.

It consists of two windings whose ends are cut at an angle to protect the O-ring. The particular advantage of this design is found in applications where there are large temperature fluctuations; it can react to deviations in tolerances and offers a wide range of applications.

Thanks to the spiral-shape, it can be installed

very easily in a short time and without any auxiliaries.

The material used ensures a high compatibility with nearly all media due to the chemical resistance which exceeds that of all other thermoplastics and elastomers.

- Very high resistance against extrusion
- Resistant to temperature fluctuations
- Extended service life of sealing components
- High compatibility with nearly all fluids
- Excellent wear-resistance
- High temperature resistance
- Easy installation without expensive auxiliaries

## MATERIAL



Type Designation Polytetrafluoroethylene PTFE  
SEALFLON

## CODING

“BRA xxx” where “xxx” is the same code of O-Ring

## FIELD OF APPLICATION

### Pressure

≤ 400 bar  
with a max. gap 0.3 mm (\*)

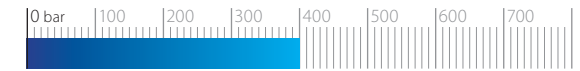

### Speed

≤ 2m/s



### Temperature

-200°C ÷ +200°C  
(only for PTFE element)

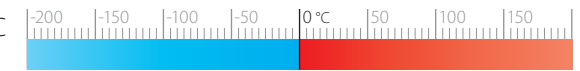

### Fluids

High compatibility with nearly all fluids  
(only for PTFE element)

(\*) for the Gap calculation, it is necessary to consider the elastic deformation of metal elements under pressure loads

## GROOVE DIMENSIONS [mm]

Section OR	h	L	L1	L2
1.78	1.4	2.5	4	5.5
2.62	1.4	3.5	5	6.5
3.53	1.4	4.5	6	7.5
5.34	1.7	7.0	9	10.5
6.99	2.5	9.5	12	14.5

Internal and external diameters are the same used for O-Rings

## SURFACE ROUGHNESS

Dynamic surface	Ra ≤ 0.3 μm	Rt ≤ 2.5 μm
Static surface	Ra ≤ 1.6 μm	Rt ≤ 6.3 μm

Before assembly good cleanliness and lubrication are recommended.

The above data are maximum values, they may be maintained for short periods and can not be used at the same time simultaneously.

# BRA

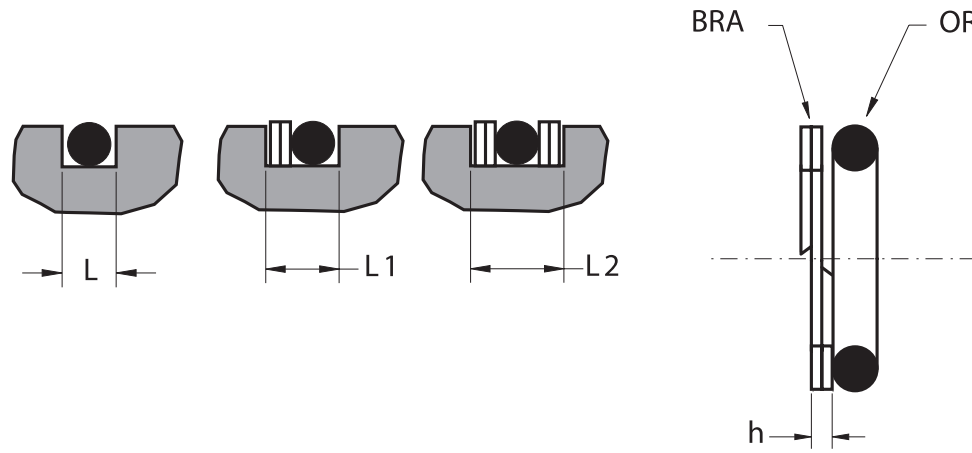

# PFS



## MATERIAL

**Type**

Polyurethane

**Designation**

SEALPUR 93

**Hardness**

93 °ShA

## FIELD OF APPLICATION

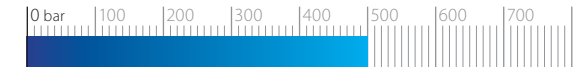
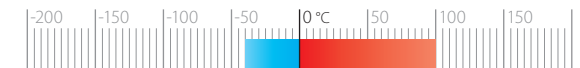
**Pressure**  
 ≤ 500 bar

**Temperature**  
 -40°C ÷ +100°C

**Fluids**

Hydraulic oils (mineral oil based)

For other fluids contact our technical department

## SURFACE ROUGHNESS

**Housing surface**

Ra ≤ 1.6 μm

Rt ≤ 6.3 μm

Before assembly good cleanliness and lubrication are recommended.

The above data are maximum values, they may be maintained for short periods and can not be used at the same time simultaneously.

The polyurethane seal type Aston Seals PFS has been developed to assure a SAE flange sealing and to substitute traditional O-Rings when they are not suitable due to difficult conditions such as high pressure or rough surface finish.

The profile is inspired by a semicompact rod seal type SD which has demonstrated great efficacy and versatility.

A flush fitting with the outside diameter reduces the radial movements induced by the frequent "pumping" phenomenon of pressure.

The material used to produce this seal is a polyurethane compound that ensures excellent properties on wear-resistance,

extended service life and resistance against extrusion

- Perfect fluid control under "pumping" pressure also
- High resistance against extrusion
- Excellent wear-resistance
- Extended service life
- Absence of induced radial movements
- Good temperature resistance
- Easy installation without expensive auxiliaries

# PFS

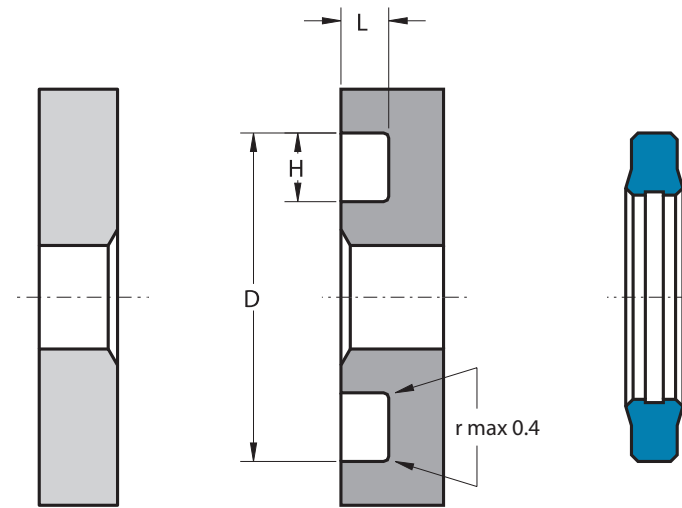

Part.	D $\pm 0.1$	H $\pm 0.25$	L $\pm 0.07$
<b>PFS 8 12 1.4</b>	12.0	2.0	1.40
<b>PFS 10.3 16.9 2.2</b>	16.9	3.3	2.20
<b>PFS 12.2 19.2 2.2</b>	19.2	3.5	2.20
<b>PFS 15.4 22.4 2.2</b>	22.4	3.5	2.20
<b>PFS 1/2"</b>	25.4	4.2	2.85
<b>PFS 3/4"</b>	31.8	4.2	2.85
<b>PFS 1"</b>	39.6	4.2	2.85
<b>PFS 1 1/4"</b>	44.5	4.2	2.85
<b>PFS 1 1/2"</b>	53.7	4.2	2.85
<b>PFS 2"</b>	63.4	4.2	2.85

# DV



## MATERIAL



Type  
Polyurethane

Designation  
SEALPUR 93

Hardness  
93 °ShA

## FIELD OF APPLICATION

Temperature  
-40°C ÷ +100°C

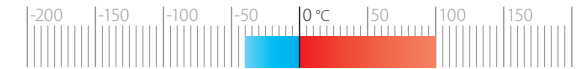

## SURFACE ROUGHNESS

Housing surface    Ra ≤ 1.6 μm    Rt ≤ 6.3 μm

Before assembly good cleanliness and lubrication are recommended.

The above data are maximum values, they may be maintained for short periods and can not be used at the same time simultaneously.

The function of V-Ring type Aston Seals DV is to prevent introduction of dust, dirt, mud and foreign matter into components such as joints, bearings and brasses.

This is achieved by the right compression of sealing lips which produces a very effective protective action and extends the service life of the component.

The DV ring compensates for axial play and allows angular swing movements up to 2°.

The material used to produce this seal is a polyurethane compound that ensures excellent properties in case of dry run, an increased wear-resistance and an extended service life.

- Excellent wear-resistance
- Extended service life
- Compensation of angular swing movements
- Good temperature resistance
- Easy installation without expensive auxiliaries

# DV

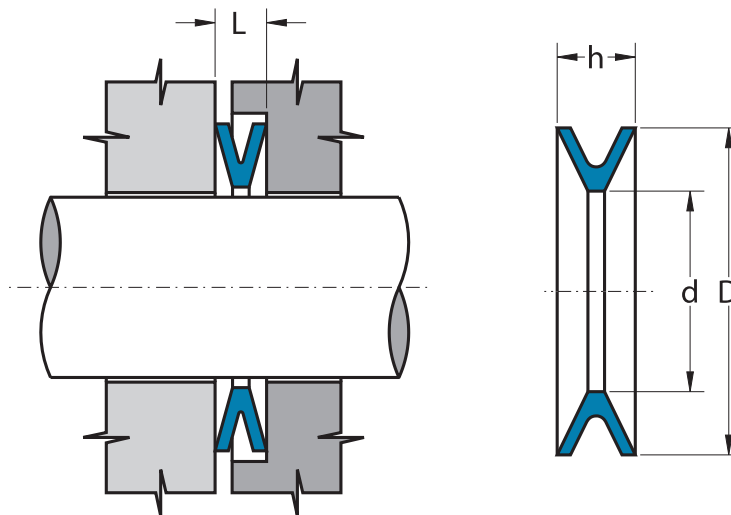

Part.	D	d	h	L
<b>DV 27.5</b>	27.5	22.5	4.0	2.0
<b>DV 32</b>	32.0	26.0	4.0	2.0
<b>DV 38.5</b>	38.5	31.0	4.5	2.0
<b>DV 43</b>	43.0	36.0	5.0	2.0
<b>DV 51</b>	51.0	42.0	6.0	2.5
<b>DV 57.5</b>	57.5	47.5	7.0	3.0
<b>DV 64</b>	64.0	54.0	7.0	3.5
<b>DV 71</b>	71.0	59.0	7.0	3.5
<b>DV 74/A</b>	74.0	61.5	8.0	3.5
<b>DV 80</b>	80.0	65.0	7.0	3.5
<b>DV 86</b>	86.0	71.0	9.0	4.0
<b>DV 86/A</b>	86.0	70.0	9.0	4.0
<b>DV 88.8</b>	88.8	70.0	8.0	3.5
<b>DV 95</b>	95.0	85.0	6.0	2.5
<b>DV 100</b>	100.0	82.0	9.0	4.5
<b>DV 105</b>	105.0	90.0	9.0	4.5
<b>DV 112</b>	112.0	96.0	10.0	5.0
<b>DV 142</b>	142.0	116.0	16.5	7.5
<b>DV 152</b>	152.0	127.0	16.5	7.5
<b>DV 162</b>	162.0	137.0	15.0	7.5
<b>DV 186</b>	186.0	160.0	16.0	7.5



# Lathe-cut products



Our sleeve turning equipment allows us to develop seals and hydraulic components from 5 to 1000 mm in size while maintaining maximum quality.

Thanks to this particular technology we are able to offer our clients rapid and customized solutions for any special requests such as single parts, small quantities or series while at the same time reducing developing time, waiting, repairing or dead times.

Our sales program foresees a range of more than 150 standard profiles that can be modified to fit your needs.

In addition we also offer a wide range of special materials all made for the seal

production and hydraulic components.

For further information and inquiries you are kindly requested to contact our technical office.

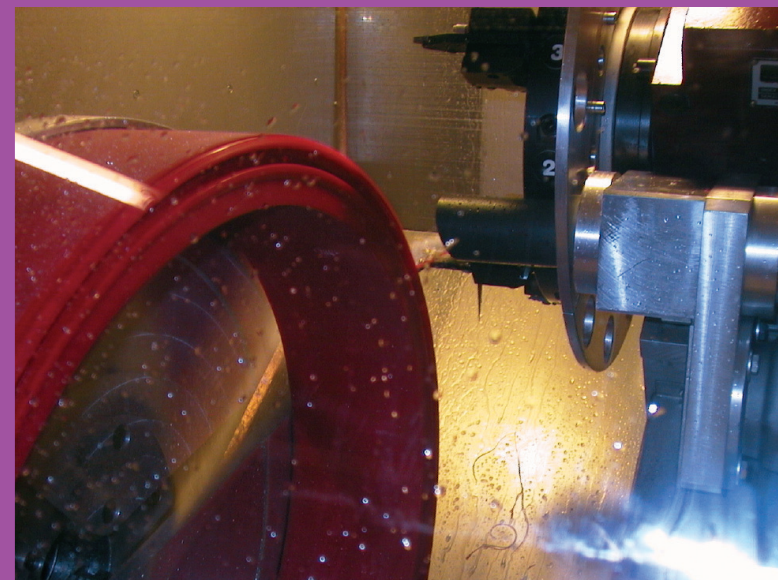



## Wipers

Profile	Type	Standard material	Pressure (bar)	Temperature (°C) *	Speed (m/s)
	T-WR01	PU NBR	-	-30 / +105 -25 / +100	4
	T-WR01A	PU NBR	-	-30 / +105 -25 / +100	4
	T-WR02	PU NBR	-	-30 / +105 -25 / +100	4
	T-WR02A	PU NBR	-	-30 / +105 -25 / +100	4
	T-WR02B	PU NBR	-	-30 / +105 -25 / +100	4
	T-WR02C	PU NBR	-	-30 / +105 -25 / +100	4
	T-WR02D	PU PU-D57	-	-30 / +105	4
	T-WR03	PU/POM NBR/POM	-	-30 / +105 -25 / +100	4
	T-WR04	PU NBR	-	-30 / +105 -25 / +100	4
	T-WR07	POM PA	-	-50 / +80 -50 / +80	1

Profile	Type	Standard material	Pressure (bar)	Temperature (°C) *	Speed (m/s)
	T-WR08	POM PA	-	-50 / +80 -50 / +80	1
	T-WR11	PU NBR	15	-30 / +105 -25 / +100	4
	T-WR12	PU NBR	-	-30 / +105 -25 / +100	4
	T-WR13	PTFE/NBR	15	-25 / +100	10
	T-WR13_EZ	PTFE/NBR	15	-25 / +100	10
	T-WR14	PTFE/NBR	-	-25 / +100	10
	T-WR15	PTFE/NBR	15	-25 / +100	10
	T-WR17	PU NBR	-	-30 / +105 -25 / +100	4
	T-WR18	PU NBR	-	-30 / +105 -25 / +100	4

\* The temperature can change choosing different materials according to working conditions.

# Profiles

## Rod seals

Profile	Type	Standard material	Pressure (bar)	Temperature (°C) *	Speed (m/s)
	T-RS01	PU NBR FPM	400 160 160	-30 / +105 -25 / +100 -20 / +210	0,5
	T-RS01A	PU NBR FPM	300 160 160	-30 / +105 -25 / +100 -20 / +210	1
	T-RS01B	PU NBR FPM	400 160 160	-30 / +105 -25 / +100 -20 / +210	0,5
	T-RS01C	PU NBR FPM	400 160 160	-30 / +105 -25 / +100 -20 / +210	0,5
	T-RS02	PU/POM NBR/POM FPM/PTFE	700 250 250	-30 / +100 -25 / +100 -20 / +210	0,5
	T-RS02A	PU/POM NBR/POM FPM/PTFE	700 250 250	-30 / +100 -25 / +100 -20 / +210	0,5
	T-RS02B	PU/PTFE	400	-30 / +105	0,5
	T-RS02C	PU/POM	700	-25 / +100	5
	T-RS03	PU/NBR	400	-25 / +100	0,5
	T-RS04	PU/NBR/POM	700	-25 / +100	0,5
	T-RS05	PU NBR	25	-30 / +105 -25 / +100	1
	T-RS08	PU NBR	400 160	-30 / +105 -25 / +100	0,3

Profile	Type	Standard material	Pressure (bar)	Temperature (°C) *	Speed (m/s)
	T-RS09	PU-D57/NBR PTFE/NBR	600	-25 / +100	5 10
	T-RS09A	PU-D57/NBR PTFE/NBR	600	-25 / +100	5 10
	T-RS09B	PU-D57/NBR PTFE/NBR	600	-25 / +100	5 10
	T-RS91	PU-D57/NBR PTFE/NBR	600	-25 / +100	5 10
	T-RS91B	PU-D57/NBR PTFE/NBR	600	-25 / +100	5 10
	T-RS16	PU NBR	160	-30 / +105 -25 / +100	0,5
	T-RS17	PU NBR	400 160	-30 / +105 -25 / +100	0,5
	T-RS17A	PU/POM	700	-30 / +100	0,5
	T-RS17B	PU/NBR	400	-25 / +100	0,5
	T-RS17C	PU/NBR/POM	700	-25 / +100	0,5
	T-RS17D	PU NBR	400 160	-30 / +105 -25 / +100	0,5
	T-RS17E	PU/POM	700	-30 / +100	0,4

\* The temperature can change choosing different materials according to working conditions.

## Rod seals

Profile	Type	Standard material	Pressure (bar)	Temperature (°C) *	Speed (m/s)
	T-RS19	PTFE-virgin / V-spring PTFE-filled / V-spring	200 400	-200 / +260	15
	T-RS19A	PTFE/V-spring	150	-200 / +260	2
	T-RS20	NBR/POM	700	-25 / +100	0,5
	T-RS31-33	PU/POM	500	-30 / +100	0,5
	T-RS35	PU	400	-30 / +105	0,4

## Piston seals

Profile	Type	Standard material	Pressure (bar)	Temperature (°C) *	Speed (m/s)
	T-PS01	PU NBR FPM	400 160 160	-30 / +105 -25 / +100 -20 / +210	0,5
	T-PS01A	PU NBR FPM	300 160 160	-30 / +105 -25 / +100 -20 / +210	0,5
	T-PS01B	PU NBR FPM	400 160 160	-30 / +105 -25 / +100 -20 / +210	0,5
	T-PS01C	PU NBR FPM	400 160 160	-30 / +105 -25 / +100 -20 / +210	0,5
	T-PS02	PU/POM NBR/POM FPM/PTFE	700 250 250	-30 / +100 -25 / +100 -20 / +210	0,5
	T-PS02A	PU/POM NBR/POM FPM/PTFE	700 250 250	-30 / +100 -25 / +100 -20 / +210	0,5
	T-PS03	PU/NBR	400	-25 / +100	0,5
	T-PS04	PU/NBR/POM	700	-25 / +100	0,5
	T-PS05	PU NBR	25	-30 / +105 -25 / +100	1
	T-PS08	PU-57D/NBR PTFE/NBR	600	-25 / +100	5 15
	T-PS08A	PU/NBR PU-57D/NBR	250 400	-25 / +100	1 5
	T-PS08B	PU-57D/NBR PTFE/NBR	600	-25 / +100	5 10

\* The temperature can change choosing different materials according to working conditions.

# Profiles

## Piston seals

Profile	Type	Standard material	Pressure (bar)	Temperature (°C) *	Speed (m/s)
	T-PS08C	PTFE/NBR	400	-25 / +100	2
	T-PS08D	PTFE/NBR	400	-25 / +100	3
	T-PS08E	PU-57D/NBR PTFE/NBR	600	-25 / +100	5 10
	T-PS08F	PU/NBR PU-57D/NBR	250 400	-25 / +100	1 5
	T-PS81	PU-57D/NBR PTFE/NBR	600	-25 / +100	5 10
	T-PS81B	PU-57D/NBR PTFE/NBR	600	-25 / +100	5 10
	T-PS09	PU/NBR/POM	400	-25 / +100	0,5
	T-PS09A	PTFE/NBR/POM	400	-25 / +100	1
	T-PS16	PU NBR	160	-30 / +105 -25 / +100	0,5
	T-PS16A	PU NBR	160	-30 / +105 -25 / +100	0,5
	T-PS17	PU/POM NBR/POM	400 250	-25 / +100	0,5
	T-PS17A	PU/POM NBR/POM	400 250	-25 / +100	0,5

Profile	Type	Standard material	Pressure (bar)	Temperature (°C) *	Speed (m/s)
	T-PS17B	PU/POM NBR/POM	400 250	-25 / +100	0,5
	T-PS19	PTFE-virgin / V-spring PTFE-filled / V-spring	200 400	-200 / +260	15
	T-PS19A	PTFE-virgin / V-spring PTFE-filled / V-spring	200 400	-200 / +260	2
	T-PS20	NBR/POM	700	-25 / +100	0,5
	T-PS23	PU/NBR/POM	400	-25 / +100	0,5
	T-PS35	PU	400	-30 / +105	0,4

\* The temperature can change choosing different materials according to working conditions.

## Symmetric seals (for rod and piston)

Profile	Type	Standard material	Pressure (bar)	Temperature (°C) *	Speed (m/s)
	T-PRS06	PU NBR	400 160	-30 / +105 -25 / +100	0,5
	T-PRS06A	PU NBR	300 160	-30 / +105 -25 / +100	0,5
	T-PRS06B	PU NBR	400 160	-30 / +105 -25 / +100	0,5
	T-PRS06C	PU NBR	400 160	-30 / +105 -25 / +100	0,3
	T-PRS06D	PU NBR	400 160	-30 / +105 -25 / +100	0,5
	T-PRS06E	PU NBR	400 160	-30 / +105 -25 / +100	0,5
	T-PRS07	PU/NBR	400	-25 / +100	0,5
	T-PRS10SP	PU FPM POM	-	-30 / +105 -20 / +210 -60 / +100	-
	T-PRS10-12	PU/POM NBR/POM	500 250	-30 / +100 -25 / +100	0,5
	T-PRS13-15	PU/POM NBR/POM	500 250	-30 / +100 -25 / +100	0,5
	T-PRS18	PU/NBR	400	-25 / +100	0,5

Profile	Type	Standard material	Pressure (bar)	Temperature (°C) *	Speed (m/s)
	T-PRS19	PTFE-virgin / V-spring  PTFE-filled / V-spring	200  400	-200 / +260	15
	T-PRS19B	PTFE-virgin/ Helicoil spring  PTFE-filled/ Helicoil spring	200  400	-200 / +260	5
	T-PRS19C	PTFE-virgin/ Helicoil spring  PTFE-filled/ Helicoil spring	200  400	-200 / +260	5
	T-PRS19D	PTFE-virgin/ Helicoil spring  PTFE-filled/ Helicoil spring	200  400	-200 / +260	5
	T-PRS22	PU/POM NBR/POM FPM/PTFE	400 160 160	-30 / +100 -25 / +100 -20 / +210	0,5
	T-PRS25-27	PTFE-virgin PTFE-filled	100	-200 / +260	1,5
	T-PRS99	PU NBR FPM	400 160 160	-30 / +105 -25 / +100 -20 / +210	0,5

\* The temperature can change choosing different materials according to working conditions.

# Profiles

## Back-up rings

Profile	Type	Standard material	Pressure (bar)	Temperature (°C) *	Speed (m/s)
	T-BUR08	POM PTFE	-	-60 / +100 -200 / +260	-
	T-BUR09	POM PTFE	-	-60 / +100 -200 / +260	-
	T-BUR10	POM PTFE	-	-60 / +100 -200 / +260	-
	T-BUR11	POM PTFE	-	-60 / +100 -200 / +260	-
	T-BUR12	POM PTFE	-	-60 / +100 -200 / +260	-
	T-BUR13	POM PTFE	-	-60 / +100 -200 / +260	-

## Guide rings

Profile	Type	Standard material	Pressure (bar)	Temperature (°C) *	Speed (m/s)
	T-BWR01	POM PTFE	-	-60 / +100 -200 / +260	4
	T-BWR01A	POM PTFE	-	-60 / +100 -200 / +260	4
	T-BWR03	POM PTFE	-	-60 / +100 -200 / +260	4
	T-BWR04	POM PTFE	-	-60 / +100 -200 / +260	4
	T-BWR05	POM PTFE	-	-60 / +100 -200 / +260	4
	T-BWR06	POM PTFE	-	-60 / +100 -200 / +260	4
	T-BWR07	POM PTFE	-	-60 / +100 -200 / +260	4
	T-BWR08	POM PTFE	-	-60 / +100 -200 / +260	4
	T-BWR09	-	-	-	-

\* The temperature can change choosing different materials according to working conditions.

## Rotary seals

Profile	Type	Standard material	Pressure (bar)	Temperature (°C) *	Speed (m/s)
	T-OS01	PU/POM NBR/POM FPM/PTFE	0,5 0,5 0,5	-30 / +100 -25 / +100 -20 / +210	5 10 15
	T-OS02	PU/POM NBR/POM FPM/PTFE	0,5 0,5 0,5	-30 / +100 -25 / +100 -20 / +210	5 10 15
	T-OS03	PU NBR FPM	0,5 0,5 0,5	-30 / +100 -25 / +100 -20 / +210	5 10 15
	T-OS08	PU NBR	-	-30 / +105 -25 / +100	5 10
	T-OS08A	PU NBR	-	-30 / +105 -25 / +100	5 10
	T-R03	PU/POM NBR/POM	400 250	-30 / +100 -25 / +100	0,2 0,2
	T-R04	PU NBR	160 100	-30 / +105 -25 / +100	0,2 0,2
	T-R04A	PU NBR	160 100	-30 / +105 -25 / +100	0,2 0,2
	T-R05	PU NBR	160 100	-30 / +105 -25 / +100	0,2 0,2
	T-R05A	PU NBR	160 100	-30 / +105 -25 / +100	0,2 0,2

Profile	Type	Standard material	Pressure (bar)	Temperature (°C) *	Speed (m/s)
	T-VR06	NBR	-	-25 / +100	25
	T-VR07	NBR	-	-25 / +100	25
	T-R08	PTFE/NBR	350	-25 / +100	0,4
	T-R08D	PTFE/NBR	350	-25 / +100	0,4
	T-R09	PTFE/NBR	350	-25 / +100	0,4
	T-R09A	PTFE/NBR	350	-25 / +100	0,4
	T-R10	PTFE/NBR	350	-25 / +100	0,4
	T-R10A	PTFE/NBR	350	-25 / +100	0,4
	T-R11	PTFE/NBR	350	-25 / +100	0,4
	T-R11D	PTFE/NBR	350	-25 / +100	0,4







\* The temperature can change choosing different materials according to working conditions.

# Profiles

## Static seals and O-Rings

Profile	Type	Standard material	Pressure (bar)	Temperature (°C) *	Speed (m/s)
	T-FL01A	PU FPM EPDM	400 250 250	-30 / +105 -20 / +210 -50 / +130	-
	T-FL02B	PU FPM EPDM	400 250 250	-30 / +105 -20 / +210 -50 / +130	-
	T-FL03	PU NBR FPM	600 250 250	-30 / +105 -25 / +100 -20 / +210	-
	T-FL06	PTFE-virgin/ Helicoil spring PTFE-filled/ Helicoil spring	200 400	-60 / +200	0,1
	T-FL07	PTFE-virgin/ Helicoil spring PTFE-filled/ Helicoil spring	200 400	-60 / +200	0,1
	T-OR	PU NBR FPM	600 160 160	-30 / +105 -25 / +100 -20 / +210	-
	T-ORH	PU NBR FPM	600 160 160	-30 / +105 -25 / +100 -20 / +210	-
	T-ORV	PU NBR FPM	600 160 160	-30 / +105 -25 / +100 -20 / +210	-
	T-QR01	PU NBR FPM	600 160 160	-30 / +105 -25 / +100 -20 / +210	-
	T-QR02	PU NBR FPM	600 160 160	-30 / +105 -25 / +100 -20 / +210	-
	T-SS01	PU NBR FPM	600 250 250	-30 / +105 -25 / +100 -20 / +210	-

## Customized seals and machined parts

Profiles					
					
					

\* The temperature can change choosing different materials according to working conditions.



## Mining seals

Profile	Type	Standard material	Pressure (bar)	Temperature (°C) *	Speed (m/s)
	T-P50	PU/POM	400 dyn. 1500 stat.	-30 / +100	0,5 0,2
	T-P50A	PU/POM	400 dyn. 1500 stat.	-30 / +100	0,5 0,2
	T-P51	PU/NBR/POM	400 dyn. 1500 stat.	-25 / +100	0,5 0,2
	T-P51A	PU/NBR/POM	400 dyn. 1500 stat.	-25 / +100	0,5 0,2
	T-P51G	PU/NBR/POM	400 dyn. 1500 stat.	-25 / +100	0,5 0,2
	T-P52	PU/POM	700 dyn. 1500 stat.	-30 / +100	0,5 0,2
	T-P53	PU/NBR/POM	700 dyn. 1500 stat.	-25 / +100	0,5 0,2
	T-P54	PU/NBR/POM	400 dyn. 1500 stat.	-25 / +100	0,5 0,2
	T-P54A	PU/NBR/POM	400 dyn. 1500 stat.	-25 / +100	0,5 0,2
	T-P55	PU/POM NBR/POM	700 dyn./ 1500 stat. 400 dyn./ 1500 stat.	-25 / +100	0,5/0,2 0,5/0,2
	T-R50	PU/NBR/POM	700	-25 / +100	0,5

Profile	Type	Standard material	Pressure (bar)	Temperature (°C) *	Speed (m/s)
	T-R50A	PU/NBR/POM	700	-25 / +100	0,5
	T-R51	PU/NBR	400	-25 / +100	0,5
	T-R52	PU/POM	700	-30 / +100	0,5
	T-R53	PU	400	-30 / +105	0,5
	T-W50	PU	-	-30 / +105	2
	T-W51	PU	-	-30 / +105	2
	T-W53	PU/POM	-	-30 / +80	2
	T-W54	PU	-	-30 / +105	2
	T-BWR01-P	POM PTFE	-	-60 / +100 -200 / +260	4
	T-BWR01-R	POM PTFE	-	-60 / +100 -200 / +260	4
	T-P58	PU	400	-30 / +105	0,3

\* The temperature can change choosing different materials according to working conditions.

# Materials

Color	Material	cod.	Temp. (°C) *	Hardness	Approved FDA	Main application and notes
	PU red	P	-30 / +125	95 °ShA	✓	U-rings, wiper rings and other seal elements. Mineral oil, compressed air, water. Resistant against hydrolysis.
	PU light green	P1	-30 / +115	88 °ShA		U-rings, wiper rings and other seal elements. Mineral oil, compressed air, water. Application for pneumatic and low pressure
	PU orange	P2	-30 / +135	96 °ShA		U-rings, wiper rings and other seal elements. Mineral oil, compressed air, water. Application at elevated temperature.
	PU violet	P3	-30 / +115	95 °ShA	✓	U-rings, wiper rings and other seal elements. Mineral oil, compressed air, water. Improved chemical resistance, suitable for CIP processes. Applicable for contact with foodstuff.
	PU light blue	X	-50 / +105	95 °ShA	✓	U-rings, wiper rings and other seal elements. Mineral oil, compressed air, water. Application at low temperature.
	PU dark red	M	-30 / +125	96 °ShA		U-rings, wiper rings and other seal elements. Mineral oil, compressed air, water. Improved wear and friction properties for water hydraulics, and heavy duty applications with insufficient lubrication.
	PU blue	Q	-30 / +125	57 °ShD	✓	U-rings, wiper rings and other seal elements. Mineral oil, compressed air, water. High pressure and extrusion resistance.
	PU grey	Q2	-30 / +125	57 °ShD		U-rings, wiper rings and other seal elements. Mineral oil, compressed air, water. High pressure and extrusion resistance. Improved wear and friction properties.
	PU	R	-20 / +115	95 °ShA	✓	U-rings, wiper rings and other seal elements. Mineral oil, compressed air, water. High abrasion resistance.
	PU	R2	-37 / +110	96 °ShA	✓	U-rings, wiper rings and other seal elements. Mineral oil, compressed air, water. High abrasion resistance.

POLYURETHANE \*all polyurethane grades resistant to hydrolysis

# Materials

Color	Material	cod.	Temp. (°C) *	Hardness	Approved FDA	Main application and notes	
	NBR	N	-25 / +100	85 °ShA		U-rings, wiper rings and other seal elements. Mineral oil, compressed air, water.	NBR
	NBR 95	A	-25 / +100	95 °ShA		U-rings, wiper rings and other seal elements. Mineral oil, compressed air, water. High extrusion resistance.	
	NBR FDA	F	-22 / +100	85 °ShA	✓	U-rings, wiper rings and other seal elements. Mineral oil, compressed air, water. Applicable for contact with foodstuff.	
	H-NBR	H	-25 / +150	85 °ShA		U-rings, wiper rings and other seal elements. Mineral oil, compressed air, water. Application for fluids at high temperature, cold water.	
	FPM (viton)	V	-20 / +210	85 °ShA		U-rings, wiper rings and other seal elements. Mineral oil, compressed air, water. Application for fluids at high temperature and aggressive.	FPM
	FPM FDA (viton)	V2	-25 / +210	85 °ShA	✓	U-rings, wiper rings and other seal elements. Mineral oil, compressed air, water. Application for fluids at high temperature and aggressive. Applicable for contact with foodstuff.	
	EPDM	E	-50/+130	85 °ShA		U-rings, wiper rings and other seal elements. Hot water and steam, ozone diluite acids and alkaline solutions. NOT resistant against mineral oils.	EPDM
	EPDM FDA	Z	-50/+100	85 °ShA	✓	U-rings, wiper rings and other seal elements. Hot water and steam, ozone diluite acids and alkaline solutions. NOT resistant against mineral oils. Applicable for contact with foodstuff.	
	Silicone FDA	S	-55/+210	85 °ShA	✓	Flanges seals, gasket and other static seals. For dynamic application is NOT recommended. Applicable for contact with foodstuff.	SILICONE
	Silicone FDA	S2	-55/+210	85 °ShA	✓	Flanges seals, gasket and other static seals. For dynamic application is NOT recommended. Applicable for contact with foodstuff.	

# Materials

Color	Material	cod.	Temp. (°C) *	Hardness	Approved FDA	Main application and notes	
	AFLAS	I	-15/+210	85 °ShA		U-rings, wiper rings and other seal elements. Hot water and steam, brake fluids, sour oil and gas. High electrical isolation properties.	TFE/P
	PTFE-P FDA	T	-200/+260	55 °ShD	✓	Composite seals with elastomer preload elements, spring loaded seal, back-up and guide rings, low friction, excellent chemical resistance. Applicable for contact with foodstuff.	PTFE
	PTFE-40%	B	-200/+260	64 °ShD		Composite seals with elastomer preload elements, spring loaded seal, back-up and guide rings, low friction, excellent chemical resistance. Filled with 40% bronze for improved wear, low friction.	
	PTFE-60%	B6	-200/+260	67 °ShD		Composite seals with elastomer preload elements, spring loaded seal, back-up and guide rings, low friction, excellent chemical resistance. Filled with 60% bronze for improved wear, low friction.	
	PTFE-25%	C	-200/+260	64 °ShD		Composite seals with elastomer preload elements, spring loaded seal, back-up and guide rings, low friction, excellent chemical resistance. Filled with 25% carbon for improved wear, low friction.	
	PTFE-25%	G	-200/+260	55 °ShD		Composite seals with elastomer preload elements, spring loaded seal, back-up and guide rings, low friction, excellent chemical resistance. Filled with glass fibre/MoS2 for improved wear, low friction.	
	POM FDA	D	-50/+100	/	✓	Back-up and guide rings, machined parts. Very stable in wet and dry environments is also recommended for precision parts, where close tolerances are required.	PLASTICS
	PA FDA	Y	-30/+100	/	✓	Back-up and guide rings, machined parts.	
	PEEK	K	-50/+250	90 °ShD	✓	Composite seals with elastomer preload elements, spring loaded seal, back-up and guide rings, low friction, high precision parts.	
	UHMW-PE	U	-200/+80	63 °ShD		Composite seals with elastomer preload elements, spring loaded seal, back-up and guide rings, low friction.	



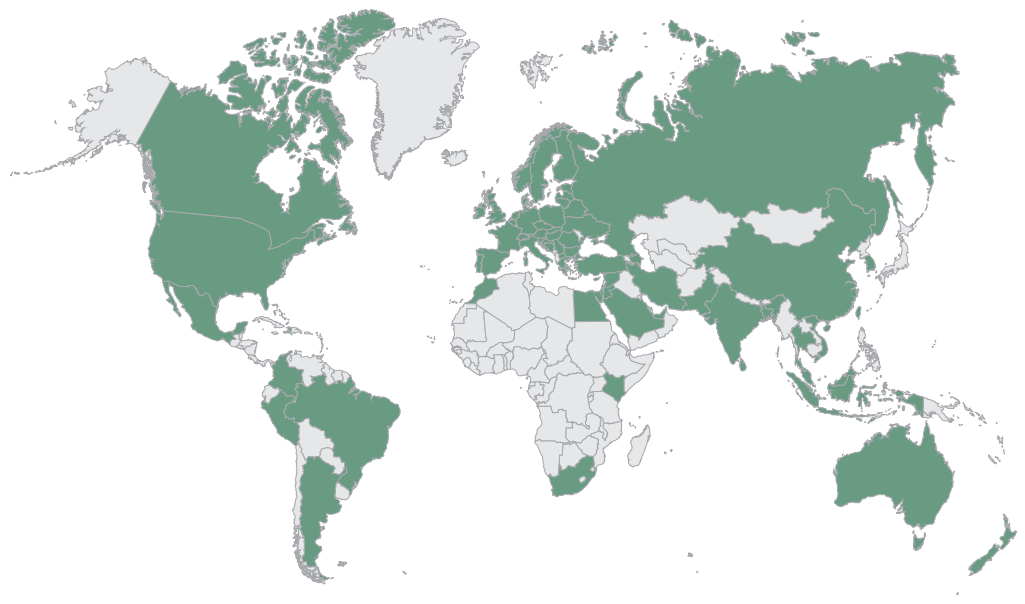

**EUROPE**

Austria  
 Belarus  
 Belgium  
 Bosnia Erzegovina  
 Bulgaria  
 Czech Republic  
 Croatia  
 Denmark  
 Estonia  
 Finland  
 France

Germany  
 Greece  
 Hungary  
 Ireland  
 Italy  
 Latvia  
 Lithuania  
 Macedonia  
 Malta  
 Netherlands  
 Norway  
 Poland

Portugal  
 Romania  
 Russia  
 Serbia  
 Slovakia  
 Slovenia  
 Spain  
 Sweden  
 Switzerland  
 Turkey  
 Ukraine  
 United Kingdom

**ASIA**

Azerbaijan  
 Bahrain  
 Bangladesh  
 China  
 Cyprus  
 Hong Kong  
 India  
 Indonesia  
 Iran  
 Israel  
 Jordan

Malaysia  
 Pakistan  
 Saudi Arabia  
 Singapore  
 South Korea  
 Sri Lanka  
 Syria  
 Taiwan  
 Thailand  
 United Arab Emirates  
 Viet Nam

**AMERICA**

Argentina  
 Brazil  
 Canada  
 Colombia  
 Haiti  
 Mexico  
 Peru  
 United States

**OCEANIA**

Australia  
 New Zealand

**AFRICA**

Egypt  
 Gambia  
 Kenya  
 Mauritius  
 Morocco  
 Seychelles  
 South Africa



ASTON SEALS

